

# Technical Comparison Guide: NanoBRET™ VHL Target Engagement Assays

**Author:** BenchChem Technical Support Team. **Date:** May 2026

## Compound of Interest

Compound Name: (S, R, S)-AHPC-PEG4-tosyl

Cat. No.: B12509354

[Get Quote](#)

## Executive Summary

The Von Hippel-Lindau (VHL) E3 ligase is a cornerstone of targeted protein degradation (TPD), serving as the recruitment handle for a vast majority of current PROTAC® degraders.[1] However, the physicochemical properties required for PROTACs (high molecular weight, polarity) often compromise cell permeability.[2] Traditional biochemical assays (FP, SPR) effectively measure binding affinity (

) but fail to account for the plasma membrane barrier.

This guide analyzes the NanoBRET™ Target Engagement (TE) Assay, a proximity-based method that quantifies ligand binding inside living cells.[1][3][4][5] We compare its performance against industry-standard alternatives (FP, SPR, CETSA) and provide a field-validated protocol for optimizing VHL-specific workflows.

## Technology Logic: The NanoBRET™ Mechanism

The NanoBRET™ system relies on Bioluminescence Resonance Energy Transfer (BRET) to report on molecular proximity.[1][3][5][6] Unlike FRET, which requires external excitation (often

causing autofluorescence), BRET uses a luciferase donor, resulting in significantly higher signal-to-noise ratios in complex biological matrices.

The System Components:

- The Target: VHL fused to NanoLuc® luciferase (19 kDa, extremely bright).
- The Probe: A cell-permeable fluorescent tracer derivatized from a known VHL binder (e.g., VH032 or HIF-1 $\alpha$  peptide).
- The Competitor: Your test compound (PROTAC or inhibitor).

The Causality of Signal:

- Equilibrium State: The Tracer enters the cell and binds the VHL-NanoLuc fusion. The proximity allows non-radiative energy transfer from NanoLuc (Donor, ~460nm) to the Tracer (Acceptor, ~618nm), generating a BRET signal.
- Displacement: If the test compound binds VHL, it competes with the Tracer.[1] As the Tracer is displaced, the BRET signal decays.[1] This loss of signal is directly proportional to the fractional occupancy of the target.

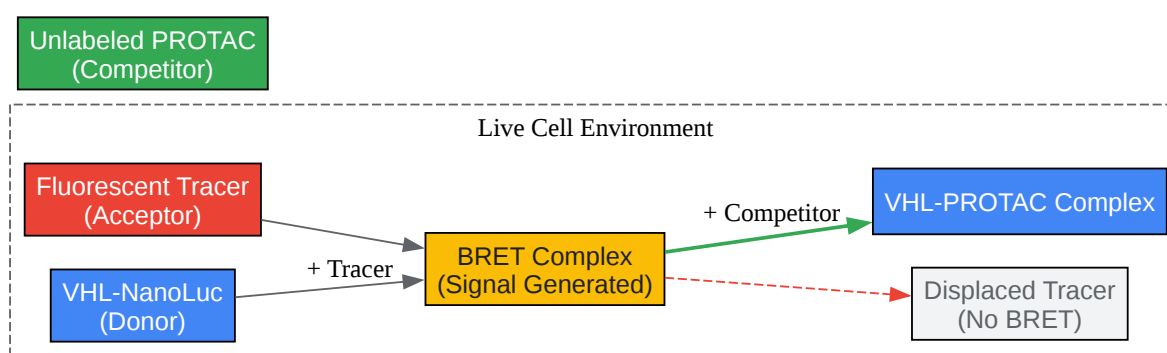

[Click to download full resolution via product page](#)

Figure 1: Mechanism of Competitive Displacement in NanoBRET™ VHL Assays. The assay measures the loss of BRET signal as the unlabeled PROTAC displaces the fluorescent tracer.

## Comparative Analysis: NanoBRET vs. Alternatives

Selecting the right assay depends on the specific question being asked: intrinsic affinity vs. functional potency.

Feature	NanoBRET™ TE (Promega)	Fluorescence Polarization (FP)	SPR (Biacore)	CETSA / HiBiT
System Context	Live Cells (Physiological ATP/Cofactors)	Purified Protein (Artificial Buffer)	Purified Protein (Immobilized)	Live Cells or Lysate
Primary Readout	Intracellular Affinity ( )	Biochemical Affinity ( / )	Kinetics ( , ' )	Thermal Stability ( shift)
Permeability	Directly Measured (Live vs. Lytic mode)	Ignored	Ignored	Implicit (but not quantified)
Throughput	High (384-well / 1536-well)	High (384-well)	Medium (Chip- based)	Medium/Low (Western) to High (Alpha)
Kinetic Capability	Real-time Residence Time	Equilibrium only	Gold Standard	Endpoint only
Data Quality	Quantitative ( derived)	Quantitative	Quantitative	Semi- Quantitative / Qualitative

Expert Insight: While SPR is superior for characterizing the ternary complex half-life in a defined system, it often misleads PROTAC development because it ignores the cell membrane.

A PROTAC with picomolar SPR affinity is useless if it cannot enter the cell. NanoBRET is currently the only high-throughput method that deconvolutes permeability from affinity by running parallel "Live Cell" (membrane intact) and "Permeabilized" (membrane removed) assays.

## Detailed Experimental Protocol

Note: This protocol assumes the use of the NanoBRET™ TE Intracellular VHL Assay (Promega).

### Phase 1: Transfection (Day 1)

To ensure trustworthiness, transfection efficiency must be kept low to moderate.

Overexpression of VHL can buffer the tracer, reducing assay sensitivity (the "Cheng-Prusoff" principle applies).

- Cell Seeding: Plate HEK293 cells at 20,000 cells/well in a 96-well white, non-binding surface (NBS) plate.
- DNA Mix: Prepare a transfection mix using a carrier DNA to VHL-NanoLuc vector ratio of 10:1.
  - Why? This "dilutes" the expression to physiological levels, preventing the "sponge effect" where excess protein sequesters the tracer.
- Incubation: Transfect using FuGENE® HD (3:1 lipid:DNA ratio) and incubate for 20–24 hours at 37°C/5% CO<sub>2</sub>.

### Phase 2: Tracer Titration (Assay Validation)

Do not skip this step. You must determine the Tracer's affinity (

) in your specific cell model to calculate the test compound's true affinity (

).

- Tracer Dilution: Prepare a 12-point serial dilution of the VHL Tracer (e.g., 0 to 1 μM).
- Treatment: Remove media and replace with Opti-MEM containing the tracer dilutions.

- Equilibration: Incubate for 2 hours at 37°C.
- Measurement: Add NanoBRET™ Nano-Glo® Substrate (10µM final) and read on a BRET-compatible plate reader (e.g., GloMax® Discover).
  - Donor Channel: 450nm (80nm bandpass).
  - Acceptor Channel: 610nm longpass.
- Calculation: Plot BRET Ratio (Acceptor/Donor) vs. [Tracer]. Fit to a "One Site – Specific Binding" model to determine the concentration required for 50% saturation ( ).
  - Operational Standard: Use the tracer at a concentration (typically 0.1–0.2 µM) for competition assays to maximize sensitivity.

### Phase 3: Competitive Binding & Permeability (Day 2)

This workflow determines the intracellular

of your PROTAC.

- Compound Prep: Prepare 1000x stocks of PROTACs in DMSO. Dilute to 10x in Opti-MEM (final DMSO <0.1%).
- Tracer Addition: Prepare Tracer Reagent at 2x the concentration determined in Phase 2.
- Cell Treatment:
  - Remove culture media.
  - Add 50 µL of 2x Tracer.
  - Add 50 µL of 2x Test Compound.
- Incubation: 2 hours at 37°C (Equilibrium).
- Detection: Add 25 µL of 5x Nano-Glo® Substrate + Extracellular NanoLuc Inhibitor.

- Note: The extracellular inhibitor quenches any signal from lysed cells or secreted luciferase, ensuring the signal is strictly intracellular.
- Read: Measure BRET Ratio.

Permeability Check (The "Lytic" Mode): To confirm if poor potency is due to permeability:

- Add Digitonin (50 µg/mL) during the incubation step. This permeabilizes the membrane.
- If

shifts significantly lower (left-shift) in the presence of Digitonin compared to live cells, your compound has a permeability liability.

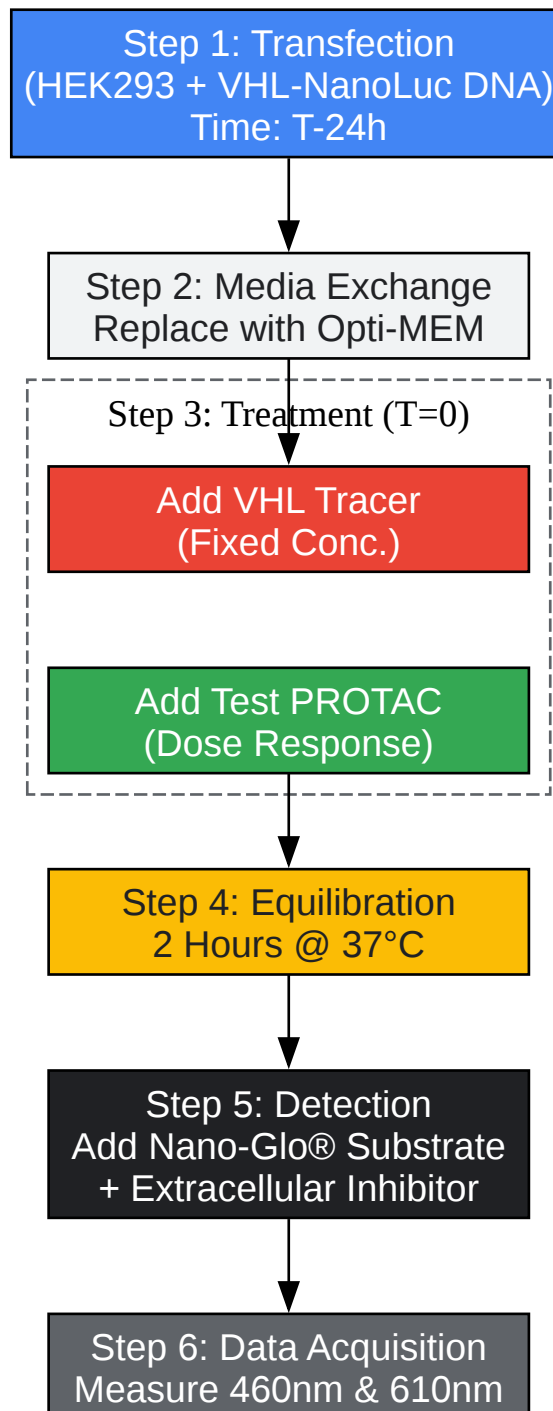

[Click to download full resolution via product page](#)

Figure 2: Optimized NanoBRET™ VHL Assay Workflow. The addition of extracellular inhibitor in Step 5 is critical for ensuring signal specificity to the intracellular compartment.

## Data Analysis & Interpretation

Raw BRET ratios must be converted to milliBRET (mBRET) units:

Calculating Absolute Affinity (

): While

is useful for ranking, the Cheng-Prusoff equation allows you to determine the absolute inhibition constant (

), which is independent of tracer concentration:

- : Derived from your dose-response curve.
- [Tracer]: The concentration added to the well.
- : Determined in Phase 2.

Residence Time Analysis: Unlike endpoint assays, NanoBRET is non-destructive. You can perform a "Jump-Dilution" or "Washout" experiment:

- Pre-incubate cells with a saturating concentration of PROTAC.
- Wash cells to remove unbound compound.
- Add Tracer immediately.
- Monitor BRET signal increase over time (kinetic mode).
- Interpretation: A slow recovery of BRET signal indicates a long residence time (slow ), which often correlates with superior degradation efficiency in vivo.

## References

- Promega Corporation. NanoBRET™ Target Engagement Intracellular E3 Ligase Assays (VHL). Technical Manual TM626. [Link](#)
- Riching, K. M., et al. (2018). Quantitative Live-Cell Kinetic Degradation and Mechanistic Profiling of PROTAC Modes of Action. ACS Chemical Biology, 13(9), 2758–2770. [Link](#)

- Robers, M. B., et al. (2015). Target engagement and drug residence time can be observed in living cells with BRET.[1][3][4][5][6][7][8][9] Nature Communications, 6, 10091. [Link](#)
- Testa, A., et al. (2020). 3-Fluoro-4-hydroxyprolines: Synthesis, Conformational Analysis, and Stereoselective Recognition by the VHL E3 Ubiquitin Ligase for Targeted Protein Degradation. Journal of the American Chemical Society, 142(14), 6654–6664. [Link](#)
- Buckley, D. L., et al. (2012). Targeting the von Hippel-Lindau E3 Ubiquitin Ligase Using Small Molecules to Disrupt the VHL/HIF-1 $\alpha$  Interaction. Journal of the American Chemical Society, 134(10), 4465–4468. [Link](#)

### Need Custom Synthesis?

BenchChem offers custom synthesis for rare earth carbides and specific isotopic labeling.

Email: [info@benchchem.com](mailto:info@benchchem.com) or [Request Quote Online](#).

## Sources

- [1. promega.com \[promega.com\]](#)
- [2. NanoBRET™ TE Intracellular E3 Ligase Assays, CRBN and VHL Technical Manual \[worldwide.promega.com\]](#)
- [3. NanoBRET® TE Intracellular E3 Ligase Assays \[worldwide.promega.com\]](#)
- [4. Quantitative, Real-Time Measurements of Intracellular Target Engagement Using Energy Transfer \[protocols.io\]](#)
- [5. NanoBRET® TE Intracellular Kinase Assays \[worldwide.promega.com\]](#)
- [6. NanoBRET® Target Engagement | Live-Cell Compound Binding Assay \[promega.sg\]](#)
- [7. キナーゼ ターゲットエンゲージメント \[promega.jp\]](#)
- [8. Comparison of the ligand-binding properties of fluorescent VEGF-A isoforms to VEGF receptor 2 in living cells and membrane preparations using NanoBRET - PubMed \[pubmed.ncbi.nlm.nih.gov\]](#)
- [9. researchgate.net \[researchgate.net\]](#)
- To cite this document: BenchChem. [Technical Comparison Guide: NanoBRET™ VHL Target Engagement Assays]. BenchChem, [2026]. [Online PDF]. Available at:

[\[https://www.benchchem.com/product/b12509354/docs#technical-comparison-guide-nanobret-vhl-target-engagement-assays\]](https://www.benchchem.com/product/b12509354/docs#technical-comparison-guide-nanobret-vhl-target-engagement-assays)

### Disclaimer & Data Validity:

The information provided in this document is for Research Use Only (RUO) and is strictly not intended for diagnostic or therapeutic procedures. While BenchChem strives to provide accurate protocols, we make no warranties, express or implied, regarding the fitness of this product for every specific experimental setup.

**Technical Support:** The protocols provided are for reference purposes. Unsure if this reagent suits your experiment?

**Need Industrial/Bulk Grade?** [Request Custom Synthesis Quote](#)

## BenchChem

Our mission is to be the trusted global source of essential and advanced chemicals, empowering scientists and researchers to drive progress in science and industry.

### Contact

Address: 3281 E Guasti Rd  
Ontario, CA 91761, United States  
Phone: (601) 213-4426  
Email: [info@benchchem.com](mailto:info@benchchem.com)

[Contact our Ph.D. Support Team for a compatibility check](#)