

# Technical Support Center: Azatyrosine Efficacy Troubleshooting

**Author:** BenchChem Technical Support Team. **Date:** May 2026

## Compound of Interest

Compound Name: Azatyrosine

CAS No.: 58525-82-9

Cat. No.: B1250254

[Get Quote](#)

Subject: Troubleshooting Low Efficacy of **Azatyrosine** (L-**Azatyrosine**) in Cell Culture Models  
Ticket ID: AZT-TS-992 Support Tier: Senior Application Scientist

## Executive Summary

If you are observing low efficacy with **Azatyrosine**, the issue is rarely the compound's potency but rather an environmental competition or readout mismatch. **Azatyrosine** (L-beta-(5-hydroxy-2-pyridyl)-alanine) acts as a tyrosine analog.[1] Its biological activity is strictly dependent on its ability to compete with L-Tyrosine for cellular uptake and protein incorporation.

This guide addresses the three most common failure modes: Nutrient Competition, Solubility Artifacts, and Endpoint Misinterpretation.

## Part 1: The "Tyrosine Trap" (Critical Failure Mode)

The Problem: Standard cell culture media (DMEM, RPMI) contain high concentrations of L-Tyrosine (approx. 400  $\mu$ M in DMEM). Because **Azatyrosine** competes with L-Tyrosine for transport via System L (LAT1) and for incorporation into proteins, a high background of L-Tyrosine effectively neutralizes the drug.

The Solution: You must optimize the **Azatyrosine**:Tyrosine Ratio.

## Mechanism of Failure: Competitive Inhibition

**Azatyrosine** functions by replacing Tyrosine in signal transduction proteins (specifically targeting c-Raf and RhoB pathways). If the extracellular L-Tyrosine concentration is high, the probability of **Azatyrosine** uptake and incorporation drops statistically.

Diagnostic Check:

- Are you using standard DMEM/RPMI? (High risk of failure)
- Is your serum concentration >10%? (FBS adds additional competing amino acids).

## Corrective Protocol: Media Formulation

To restore efficacy, you must shift the competitive balance in favor of **Azatyrosine**.

Parameter	Standard Condition (Failure Risk)	Optimized Condition (High Efficacy)
Base Media	Standard DMEM (High Tyr)	Low-Tyrosine DMEM or MEM (Custom/Dropout)
L-Tyrosine Conc.	~400 $\mu$ M	20–50 $\mu$ M (Sufficient for survival, low enough for competition)
Serum	10-15% FBS	Dialyzed FBS (Removes free amino acids)
Drug Ratio	1:10 (Aza:Tyr)	>5:1 (Aza:Tyr)

## Part 2: Visualization of Mechanisms

### Figure 1: The Competitive Transport Bottleneck

This diagram illustrates the competition between L-Tyrosine and **Azatyrosine** for the LAT1 transporter. High extracellular Tyrosine blocks **Azatyrosine** entry.

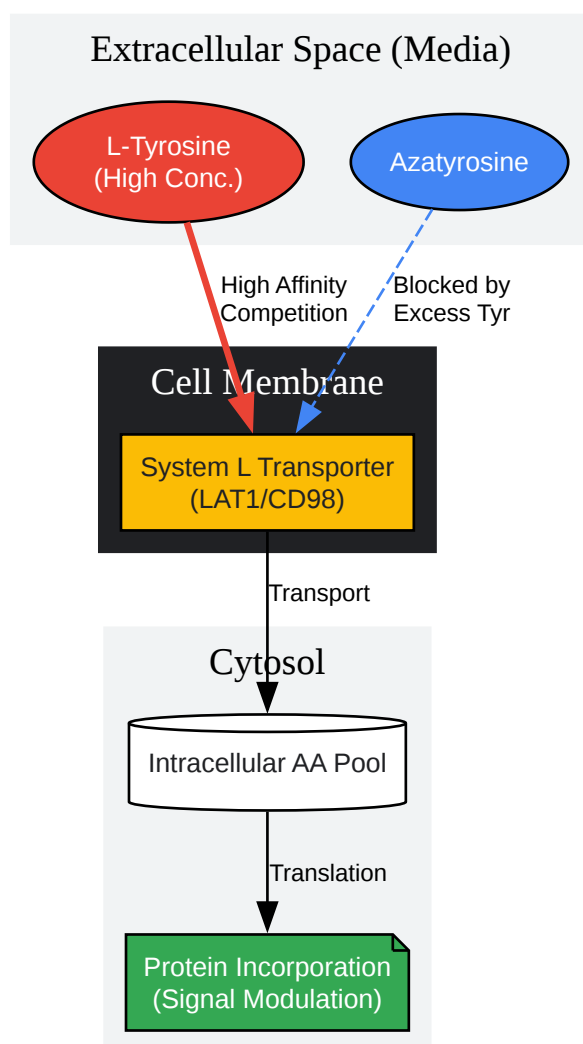

[Click to download full resolution via product page](#)

Caption: Figure 1. Competitive uptake at the LAT1 transporter.[2] Excess L-Tyrosine (Red) prevents **Azatyrosine** (Blue) from entering the intracellular pool.

## Figure 2: Downstream Signaling Reversion

**Azatyrosine** does not inhibit Ras GTP-loading.[1] Instead, it inhibits c-Raf activation and restores RhoB expression, leading to phenotypic reversion (flattening).

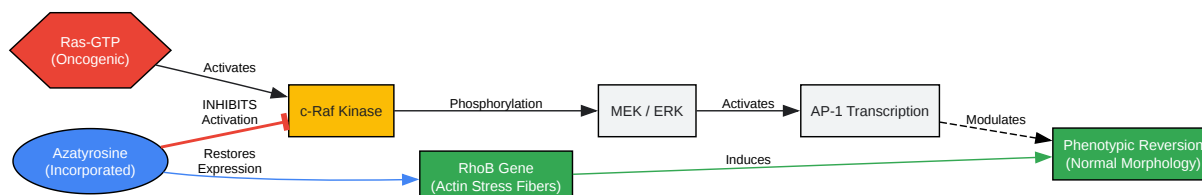

[Click to download full resolution via product page](#)

Caption: Figure 2. Mechanism of Action. **Azatyrosine** blocks the Ras-driven activation of c-Raf and restores RhoB, driving the cell toward a normalized phenotype.[1]

## Part 3: Preparation & Solubility (Technical FAQ)

Q: My **Azatyrosine** precipitates when added to the media. What is happening? A: **Azatyrosine**, like Tyrosine, has poor solubility at neutral pH (pH 7.0–7.4).

- Do NOT attempt to dissolve directly in water or PBS at neutral pH.
- Protocol: Dissolve **Azatyrosine** in 0.1 N HCl or 0.1 N NaOH to create a concentrated stock (e.g., 10–50 mM). Alternatively, DMSO can be used, but ensure the final DMSO concentration in culture is <0.1%.
- Dilution: Add the stock to the media slowly with rapid stirring. The high volume of media will buffer the small volume of acid/base/solvent.

Q: I see no cell death after 48 hours. Is the drug inactive? A: Stop looking for death.

**Azatyrosine** is primarily a differentiating agent, not a cytotoxic agent.

- Expected Readout: Look for "contact inhibition" (cells stop growing when they touch) and morphological flattening (reversion of the transformed spindle shape).
- Timeline: Phenotypic reversion often takes 5–7 days of continuous treatment. 48 hours is insufficient.

## Part 4: Validated Experimental Workflow

To confirm efficacy, perform the following "Reversion Assay":

- Cell Line Selection: Use a Ras-transformed line (e.g., NIH3T3-ras, MTSV1-7) or a line with high c-ErbB-2 activity.
- Media Prep: Prepare DMEM lacking Tyrosine. Supplement with dialyzed FBS (10%) and add back L-Tyrosine to exactly 40  $\mu$ M.
- Treatment:
  - Control: Vehicle only.
  - Experimental: Add **Azatyrosine** to a final concentration of 300–500  $\mu$ M.
- Maintenance: Replace media every 2 days (**Azatyrosine** is stable, but nutrient depletion affects phenotype).
- Endpoint Analysis (Day 6):
  - Morphology: Phase-contrast microscopy. Look for flat, non-refractile cells.
  - Biochemistry: Western blot for c-Raf (check phosphorylation status, not total protein) or RhoB induction.
  - Soft Agar: The ultimate test is the inability to form colonies in soft agar (anchorage dependence restoration).

## References

- Shindo-Okada, N., et al. (1989). "**Azatyrosine**, an antibiotic isolated from *Streptomyces chibanensis*, inhibits the growth of ras-transformed NIH 3T3 cells."[\[3\]](#) *Cancer Research*.[\[4\]](#)
- Krzyzosiak, W. J., et al. (1992). "**Azatyrosine** is incorporated into proteins instead of tyrosine residues, with the resultant conversion of transformed cells to cells with a normal phenotype."[\[1\]](#)[\[5\]](#) *Cancer Research*.[\[4\]](#)
- Mondal, K., et al. (2008).[\[2\]](#) "Functional Characterization of Tyrosine Transport in Fibroblast Cells From Healthy Controls." *Journal of Cellular Physiology*.

- Fujita-Yoshigaki, J., et al. (1992). "**Azatyrosine** inhibits the activation of c-Raf-1 kinase by oncogenic c-ErbB-2."<sup>[1]</sup> Cancer Research.<sup>[4]</sup>
- Evonik Health Care. (2020). "Enhancing the solubility of L-Tyrosine in cell culture media applications." Evonik Technical Articles.

### Need Custom Synthesis?

BenchChem offers custom synthesis for rare earth carbides and specific isotopic labeling.

Email: [info@benchchem.com](mailto:info@benchchem.com) or [Request Quote Online](#).

## Sources

- 1. Azatyrosine. Mechanism of action for conversion of transformed phenotype to normal - PubMed [[pubmed.ncbi.nlm.nih.gov](https://pubmed.ncbi.nlm.nih.gov)]
- 2. Functional characterization of tyrosine transport in fibroblast cells from healthy controls - PubMed [[pubmed.ncbi.nlm.nih.gov](https://pubmed.ncbi.nlm.nih.gov)]
- 3. Permanent conversion of mouse and human cells transformed by activated ras or raf genes to apparently normal cells by treatment with the antibiotic azatyrosine - PubMed [[pubmed.ncbi.nlm.nih.gov](https://pubmed.ncbi.nlm.nih.gov)]
- 4. Inhibition of chemical carcinogenesis in vivo by azatyrosine - PubMed [[pubmed.ncbi.nlm.nih.gov](https://pubmed.ncbi.nlm.nih.gov)]
- 5. Azatyrosine is incorporated into proteins instead of tyrosine residues, with the resultant conversion of transformed cells to cells with a normal phenotype - PubMed [[pubmed.ncbi.nlm.nih.gov](https://pubmed.ncbi.nlm.nih.gov)]
- To cite this document: BenchChem. [Technical Support Center: Azatyrosine Efficacy Troubleshooting]. BenchChem, [2026]. [Online PDF]. Available at: [<https://www.benchchem.com/product/b1250254/docs#technical-support-center-azatyrosine-efficacy-troubleshooting>]

---

### Disclaimer & Data Validity:

The information provided in this document is for Research Use Only (RUO) and is strictly not intended for diagnostic or therapeutic procedures. While BenchChem strives to provide

accurate protocols, we make no warranties, express or implied, regarding the fitness of this product for every specific experimental setup.

**Technical Support:** The protocols provided are for reference purposes. Unsure if this reagent suits your experiment?

**Need Industrial/Bulk Grade?** [Request Custom Synthesis Quote](#)

## BenchChem

Our mission is to be the trusted global source of essential and advanced chemicals, empowering scientists and researchers to drive progress in science and industry.

### Contact

Address: 3281 E Guasti Rd

Ontario, CA 91761, United States

Phone: (601) 213-4426

Email: [info@benchchem.com](mailto:info@benchchem.com)

[Contact our Ph.D. Support Team for a compatibility check](#)