

Application Notes and Protocols: Granulysin Activity Assay Using Bacterial Cultures

Author: BenchChem Technical Support Team. **Date:** May 2026

Compound of Interest

Compound Name: *Granulosin*

Cat. No.: *B1250205*

[Get Quote](#)

For Researchers, Scientists, and Drug Development Professionals

Introduction

Granulysin is a cytolytic and proinflammatory protein found within the granules of human cytotoxic T lymphocytes (CTLs) and natural killer (NK) cells.[1][2] It plays a crucial role in the immune defense against a wide array of pathogens. Granulysin is synthesized as a 15-kDa precursor, which is then processed into a biologically active 9-kDa form.[1][3][4] This 9-kDa isoform exhibits potent antimicrobial activity against Gram-positive and Gram-negative bacteria, fungi, and parasites, including significant pathogens like *Mycobacterium tuberculosis* and *Listeria monocytogenes*. [2][5][6] The broad-spectrum activity of granulysin makes it a compelling candidate for the development of novel antimicrobial therapeutics.

This document provides a comprehensive protocol for assessing the bactericidal activity of granulysin. It details the preparation of recombinant granulysin, cultivation of bacterial targets, co-incubation procedures, and various methods for quantifying bacterial viability.

Mechanism of Bactericidal Action

Granulysin is a cationic protein that exerts its antimicrobial effects primarily by targeting and disrupting the integrity of microbial cell membranes, which are typically rich in negatively charged lipids.[5][7] Its mechanism involves more than simple membrane lysis. In a key pathway, granulysin can deliver proteases called granzymes into the bacterial cytoplasm.[8][9] Once inside, granzymes cleave critical proteins within the bacterial electron transport chain and oxidative stress defense systems.[8][10] This disruption leads to the generation of reactive oxygen species (ROS), causing rapid oxidative damage and programmed cell death in the microbe.[8][11]

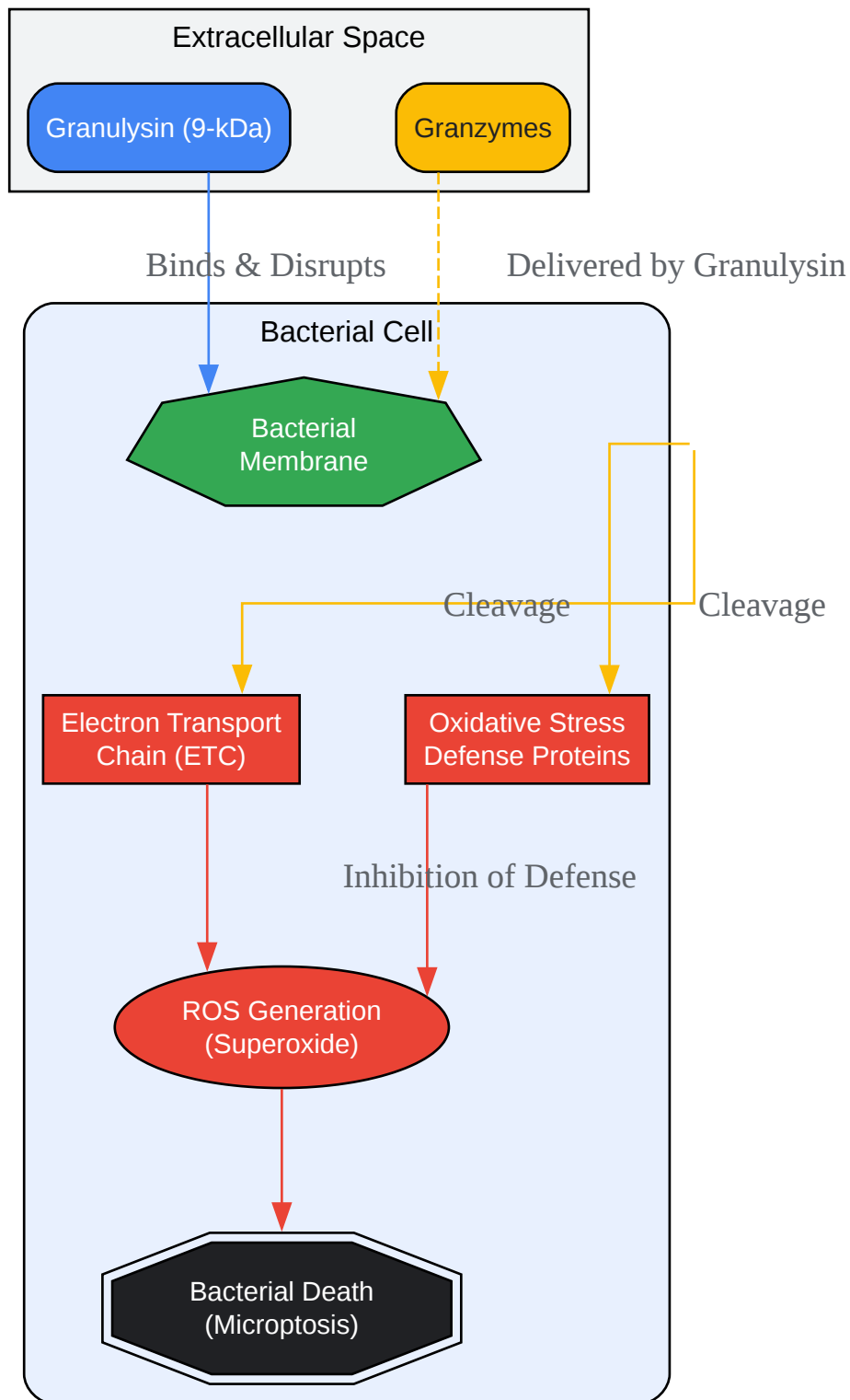

[Click to download full resolution via product page](#)

Caption: Granulysin-mediated killing of bacteria.

Experimental Workflow

The overall process for determining granulysin activity involves preparing the recombinant protein and bacterial cultures, co-incubating them under controlled conditions, and finally quantifying the resulting bacterial viability using one of several established methods.

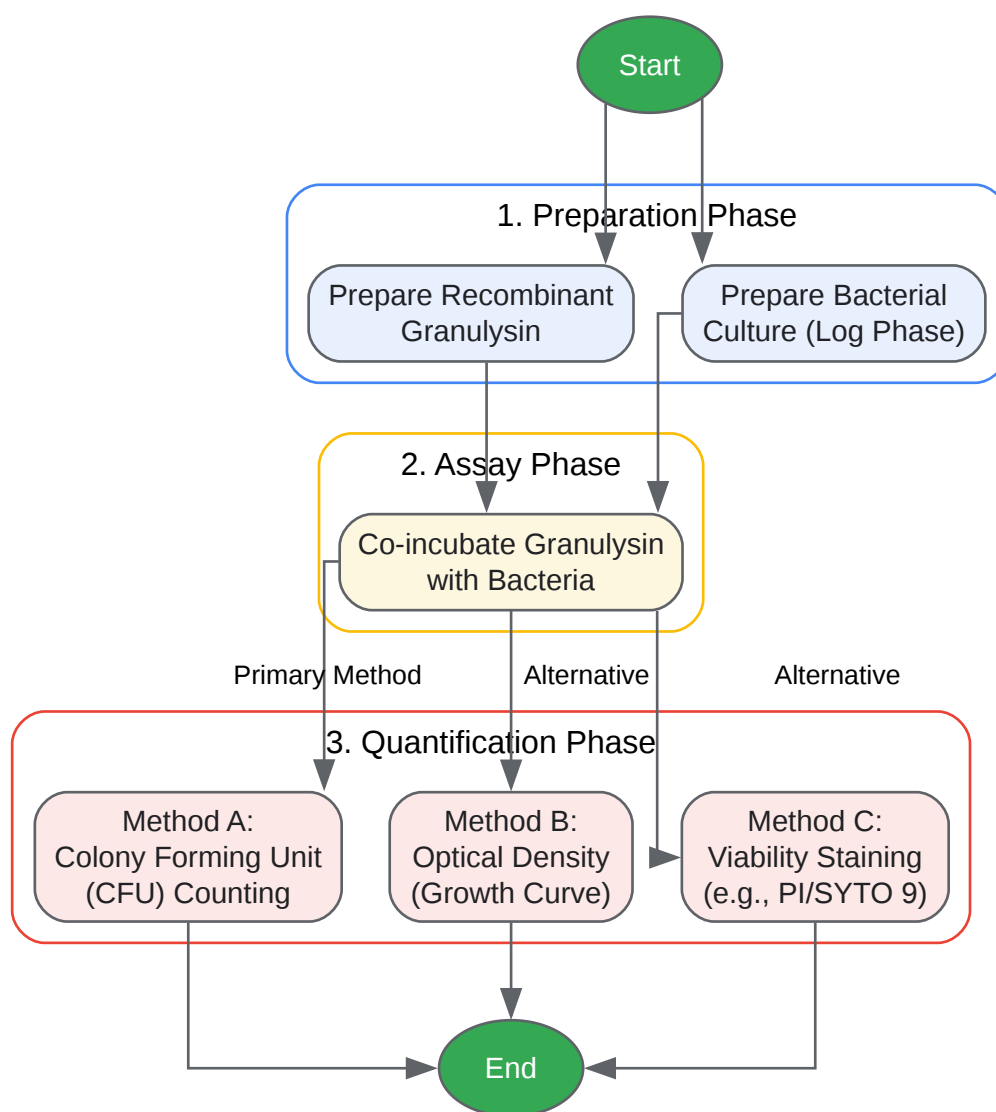

[Click to download full resolution via product page](#)

Caption: General workflow for the granulysin activity assay.

Detailed Experimental Protocols

Protocol 1: Preparation of Recombinant Granulysin

Sufficient quantities of pure, active granulysin are required for these assays. Recombinant expression is the most common method.[3] Systems like the yeast *Pichia pastoris* or mammalian HEK293 cells can be used to produce the protein.[4][12]

- Expression: Express the 9-kDa or 15-kDa form of granulysin, often with a His-tag for purification, according to established protocols for the chosen expression system (e.g., fed-batch fermentation for *P. pastoris*).[4]
- Purification: Purify the recombinant protein using affinity chromatography (e.g., Ni-IMAC for His-tagged proteins) followed by ion-exchange chromatography to achieve >95% purity.[4][12]
- Quality Control:
 - Verify protein size and purity using SDS-PAGE and Coomassie or silver staining.[12]
 - Measure protein concentration using a standard method (e.g., BCA assay).
 - Perform an endotoxin test (e.g., LAL method) to ensure low endotoxin levels (<1.0 EU per 1 µg of protein), as endotoxins can affect bacterial cultures.[13]
- Storage: Store the purified protein in a suitable buffer at -80°C in small aliquots to avoid freeze-thaw cycles.

Protocol 2: Preparation of Bacterial Cultures

- Strain Selection: Choose the bacterial strain(s) of interest. Common examples include *Escherichia coli*, *Staphylococcus aureus*, *Listeria monocytogenes*, and *Pseudomonas aeruginosa*. [8][14]
- Initial Culture: Streak the bacterial strain from a freezer stock onto an appropriate agar plate (e.g., Luria-Bertani (LB) agar for *E. coli*) and incubate overnight at 37°C.[15]
- Liquid Culture: Inoculate a single colony into a suitable broth medium (e.g., LB, Mueller-Hinton Broth (MHB), or Brain Heart Infusion (BHI)). Incubate at 37°C with shaking until the culture reaches the mid-logarithmic (exponential) growth phase (typically an OD₆₀₀ of 0.4-0.6).

- Washing and Resuspension:
 - Harvest the bacteria by centrifugation (e.g., 5000 x g for 10 min).
 - Discard the supernatant and wash the bacterial pellet once with a low-salt buffer, such as 10 mM sodium phosphate (NaPB) or 20 mM Tris, pH 7.4.[8][14] Note: High salt concentrations can inhibit granulysin activity.
 - Centrifuge again and resuspend the pellet in the same low-salt buffer.
- Concentration Adjustment: Adjust the bacterial suspension to the desired final concentration for the assay (e.g., $\sim 1 \times 10^6$ CFU/mL) by measuring the OD₆₀₀ and using a predetermined calibration curve or by dilution plating.[5]

Protocol 3: Granulysin Activity Assay (Co-incubation)

- Assay Setup: In a 96-well microtiter plate or microcentrifuge tubes, prepare serial dilutions of recombinant granulysin in the chosen low-salt assay buffer. Concentrations can range from 0.1 μ M to 200 μ M depending on the bacterial strain and expected potency.[7][15]
- Controls:
 - Negative Control: Bacteria with assay buffer only (no granulysin).
 - Positive Control (Optional): Bacteria with a known antibiotic (e.g., ciprofloxacin).[15]
- Incubation: Add the prepared bacterial suspension to each well containing the granulysin dilutions or controls. The final volume is typically 50-100 μ L.
- Incubation Conditions: Incubate the plate at 37°C for a defined period. The incubation time depends on the quantification method:
 - For CFU counting: 3 hours is a common time point.[14]
 - For growth curves (OD measurement): 18-24 hours.[16]
 - For viability staining: 20-60 minutes.[8]

Protocol 4: Quantification of Bactericidal Activity

Method A: Colony Forming Unit (CFU) Counting

This method directly measures the number of viable bacteria and is considered the gold standard for determining bactericidal activity.

- **Serial Dilution:** After incubation, perform 10-fold serial dilutions of the samples from each well in a suitable buffer (e.g., DPBS).
- **Plating:** Spot-plate or spread-plate 10-100 μL of appropriate dilutions onto agar plates.
- **Incubation:** Incubate the plates overnight at 37°C until distinct colonies are visible.
- **Enumeration:** Count the colonies on the plates. Aim for plates with 30-300 colonies for accurate counting.
- **Calculation:** Calculate the CFU/mL for each condition. Determine the percentage of killing relative to the negative control. The Minimum Bactericidal Concentration (MBC) is defined as the lowest granulysin concentration that achieves a $\geq 99.9\%$ reduction in CFU/mL compared to the initial inoculum.[\[15\]](#)[\[16\]](#)

Method B: Optical Density (Growth Curve) Measurement

This method assesses the effect of granulysin on bacterial growth over time.

- **Setup:** Perform the co-incubation (Protocol 3) in a clear, flat-bottom 96-well plate.
- **Measurement:** Place the plate in a microplate reader capable of incubation at 37°C . Measure the OD_{600} at regular intervals (e.g., every 30 minutes) for up to 24 hours.
- **Analysis:** Plot OD_{600} versus time to generate growth curves. The Minimum Inhibitory Concentration (MIC) is the lowest concentration of granulysin that completely prevents visible growth after ~ 20 hours of incubation.[\[16\]](#) A delay in the growth curve indicates bactericidal or bacteriostatic activity.[\[8\]](#)

Method C: Viability Staining

This method uses fluorescent dyes to rapidly differentiate between live and dead bacteria.

- **Staining:** After the short incubation period (e.g., 20-60 min), add a viability staining solution (e.g., LIVE/DEAD™ BacLight™ kit containing SYTO 9 and propidium iodide) to each sample according to the manufacturer's instructions. SYTO 9 stains all bacteria (live and dead), while propidium iodide (PI) only enters bacteria with compromised membranes (dead).[8]
- **Analysis:** Analyze the stained samples using:
 - **Fluorescence Microscopy:** Visualize and quantify the percentage of live (green) vs. dead (red) cells.
 - **Flow Cytometry:** Quantify the proportions of live and dead cells in a large population for more robust statistics.[8]

Data Presentation

Quantitative data from granulysin activity assays are typically summarized to determine key parameters like MIC and MBC.

Table 1: Example MIC and MBC Values for Antimicrobial Peptides against E. coli O157:H7

Peptide	MIC (μM)	MBC (μM)	Reference
Human Granulysin (hGRNL)	200	200	[15]
Porcine NK-lysin (pNKL)	6.25	6.25	[15]
Bovine NK-lysin (bNK2A)	25	25	[15]

Data obtained using the broth microdilution method in Mueller-Hinton Broth.[15]

Table 2: Antimicrobial Activity of a Granulysin-Derived Peptide Against Various Bacterial Pathogens

Bacterial Species	% Reduction in Growth (100 µM Peptide)	Reference
Bacillus anthracis (Ames)	~98%	[7]
Yersinia pestis	~95%	[7]
Francisella tularensis	~90%	[7]
Burkholderia mallei	~85%	[7]

Activity of a synthetic peptide derived from the active site of granulysin.[7]

Need Custom Synthesis?

BenchChem offers custom synthesis for rare earth carbides and specific isotopic labeling.

Email: info@benchchem.com or [Request Quote Online](#).

References

- 1. Biology and clinical relevance of granulysin - PMC [[pmc.ncbi.nlm.nih.gov](https://pubmed.ncbi.nlm.nih.gov)]
- 2. Granulysin: a novel antimicrobial peptide of cytolytic T lymphocytes and natural killer cells - PubMed [pubmed.ncbi.nlm.nih.gov]
- 3. [researchgate.net](https://www.researchgate.net) [[researchgate.net](https://www.researchgate.net)]
- 4. Production and characterization of recombinant 9 and 15 kDa granulysin by fed-batch fermentation in Pichia pastoris - PubMed [pubmed.ncbi.nlm.nih.gov]
- 5. An atomic-force basis for the bacteriolytic effects of granulysin - PMC [[pmc.ncbi.nlm.nih.gov](https://pubmed.ncbi.nlm.nih.gov)]
- 6. An atomic-force basis for the bacteriolytic effects of granulysin - PubMed [pubmed.ncbi.nlm.nih.gov]
- 7. Comparative Antimicrobial Activity of Granulysin against Bacterial Biothreat Agents [openmicrobiologyjournal.com]
- 8. Cytotoxic cells kill intracellular bacteria through Granulysin-mediated delivery of Granzymes - PMC [[pmc.ncbi.nlm.nih.gov](https://pubmed.ncbi.nlm.nih.gov)]

- 9. Granulysin, Granzymes and Perforin in Bacterial Immune Defense - Judy Lieberman [grantome.com]
- 10. Granulysin: Killer lymphocyte safeguard against microbes - PMC [pmc.ncbi.nlm.nih.gov]
- 11. childrenshospital.org [childrenshospital.org]
- 12. Improved Purification of Human Granzyme A/B and Granulysin Using a Mammalian Expression System - PMC [pmc.ncbi.nlm.nih.gov]
- 13. rndsystems.com [rndsystems.com]
- 14. researchgate.net [researchgate.net]
- 15. Comparative evaluation of antimicrobial activity of human granulysin, bovine and porcine NK-lysins against Shiga toxin-producing Escherichia coli O157:H7 - PMC [pmc.ncbi.nlm.nih.gov]
- 16. osti.gov [osti.gov]
- To cite this document: BenchChem. [Application Notes and Protocols: Granulysin Activity Assay Using Bacterial Cultures]. BenchChem, [2026]. [Online PDF]. Available at: [<https://www.benchchem.com/product/b1250205/docs#application-notes-and-protocols-granulysin-activity-assay-using-bacterial-cultures>]

Disclaimer & Data Validity:

The information provided in this document is for Research Use Only (RUO) and is strictly not intended for diagnostic or therapeutic procedures. While BenchChem strives to provide accurate protocols, we make no warranties, express or implied, regarding the fitness of this product for every specific experimental setup.

Technical Support: The protocols provided are for reference purposes. Unsure if this reagent suits your experiment?

Need Industrial/Bulk Grade? [Request Custom Synthesis Quote](#)

BenchChem

Our mission is to be the trusted global source of essential and advanced chemicals, empowering scientists and researchers to drive progress in science and industry.

Contact

Address: 3281 E Guasti Rd

Ontario, CA 91761, United States

Phone: (601) 213-4426

Email: info@benchchem.com

[Contact our Ph.D. Support Team for a compatibility check](#)