

# Technical Support Center: Flow Chemistry Optimization for Pyridine Derivatives

**Author:** BenchChem Technical Support Team. **Date:** February 2026

## Compound of Interest

Compound Name: 2-(3-Methylpyridin-2-yl)ethan-1-ol

CAS No.: 4723-26-6

Cat. No.: B125030

[Get Quote](#)

Welcome to the Advanced Flow Chemistry Support Hub. This guide is designed for process chemists and engineers encountering specific technical hurdles in the continuous flow synthesis of pyridine derivatives. Unlike standard operating procedures, this document focuses on causality—diagnosing why a reaction fails in flow and how to engineer a solution based on hydrodynamics and kinetics.

## Module 1: Reactor Engineering & Hydrodynamics

Core Challenge: Managing solids and mixing efficiency in heterogeneous pyridine syntheses.

### FAQ: Troubleshooting Clogging & Precipitation

Q: My Hantzsch pyridine synthesis is clogging the reactor coils after 20 minutes of runtime. Increasing pressure doesn't help. How do I stabilize this?

A: Clogging in Hantzsch synthesis usually stems from the precipitation of the 1,4-dihydropyridine intermediate or inorganic ammonium salts before full aromatization. Simply increasing pressure often compacts the plug rather than clearing it.

Root Cause Analysis:

- **Solubility Limit:** The dihydropyridine intermediate often has lower solubility than the starting materials (aldehyde/

-keto ester).

- Flow Dynamics: Laminar flow (low Reynolds number) in microreactors lacks the shear force to keep particles suspended.

Corrective Protocol:

- Solvent Switching: Replace standard ethanol/water mixtures with 2-Methyltetrahydrofuran (2-MeTHF). It offers higher solubility for organic intermediates and better water miscibility for ammonium acetate handling.
- Active Agitation: Implement an ultrasonic bath around the residence time coil. Continuous sonication breaks up crystal lattice formation, maintaining a slurry rather than a solid plug.
- Pulsatile Flow: If pumps allow, superimpose a sinusoidal flow pulse. This oscillation prevents particle settling at the tube walls.

“

*Technical Insight: Research by the Buchwald and Jensen groups demonstrated that ultrasound-assisted flow reactors can handle heavy precipitates in cross-coupling reactions, a principle directly applicable to heterogeneous pyridine condensations [1].*

## FAQ: Mixing Efficiency in Fast Kinetics

Q: I am performing a lithiation of 3-bromopyridine at -78°C. My yield is inconsistent, and I see significant Wurtz coupling byproducts. Why?

A: Inconsistent yields in cryogenic flow lithiation indicate poor micromixing. The rate of lithiation (

) is faster than the rate of mixing (

). When mixing is slow, local "hotspots" of high organolithium concentration favor side reactions like dimerization (Wurtz coupling) over the desired Lithium-Halogen exchange.

### Optimization Steps:

- Check Reynolds Number ( ): Ensure (turbulent flow) at the mixing junction. If your flow rate is too low, the streams are laminating (flowing side-by-side without mixing).
- Reactor Design: Switch to a T-mixer with narrow internal diameter (ID) (e.g., 0.5 mm) or a static mixer chip immediately before the residence coil.
- Temperature Management: Ensure the precooling loop is sufficiently long. The reagents must be at  $-78^{\circ}\text{C}$  before they hit the mixer.

## Module 2: Reaction Specifics (Protocols & Chemistry)

### Standard Operating Protocol: Cryogenic Lithiation-Substitution of Pyridines

Objective: Selective C3-functionalization of pyridine via Lithium-Halogen exchange. Key Advantage: Flow chemistry allows this reaction to occur at higher temperatures ( $-40^{\circ}\text{C}$  vs  $-78^{\circ}\text{C}$  in batch) due to precise residence time control, preventing the unstable pyridyl-lithium species from decomposing.

### Experimental Workflow

Parameter	Setting	Rationale
Substrate	3-Bromopyridine (0.5 M in THF)	THF coordinates Li, stabilizing the intermediate.
Reagent	n-Butyllithium (0.5 M in Hexanes)	Matches stoichiometry; hexanes co-solvent aids heat dissipation.
Electrophile	Benzaldehyde (0.6 M in THF)	Slight excess ensures full capture of the lithiated species.
Temperature	-78°C (Mixer & Reactor 1)	Kinetic control to prevent isomerization.
Residence Time	0.5 – 2.0 seconds (Zone 1)	Critical: Long enough to lithiate, short enough to prevent decomposition.
Quench	Methanol / Water	Terminates reaction immediately after Zone 2.

## Step-by-Step Execution:

- System Prep: Dry all lines with anhydrous THF. Moisture is the primary failure mode.
- Pre-cooling: Pump Substrate and n-BuLi through separate cooling loops (2 mL volume) submerged in the cryostat.
- Lithiation (Zone 1): Combine streams in a PEEK T-mixer. Pass through a short reactor coil (calculated for 0.5s residence time).
- Electrophile Addition (Zone 2): Introduce the Electrophile stream via a second T-mixer.
- Reaction (Zone 3): Pass through a larger coil (residence time ~30s) to allow substitution.
- Quench: Collect output into a stirred flask containing MeOH.

## Module 3: Visualization & Logic

## Troubleshooting Logic Tree: Pressure vs. Conversion

Use this decision matrix to diagnose flow reactor failures during pyridine synthesis.

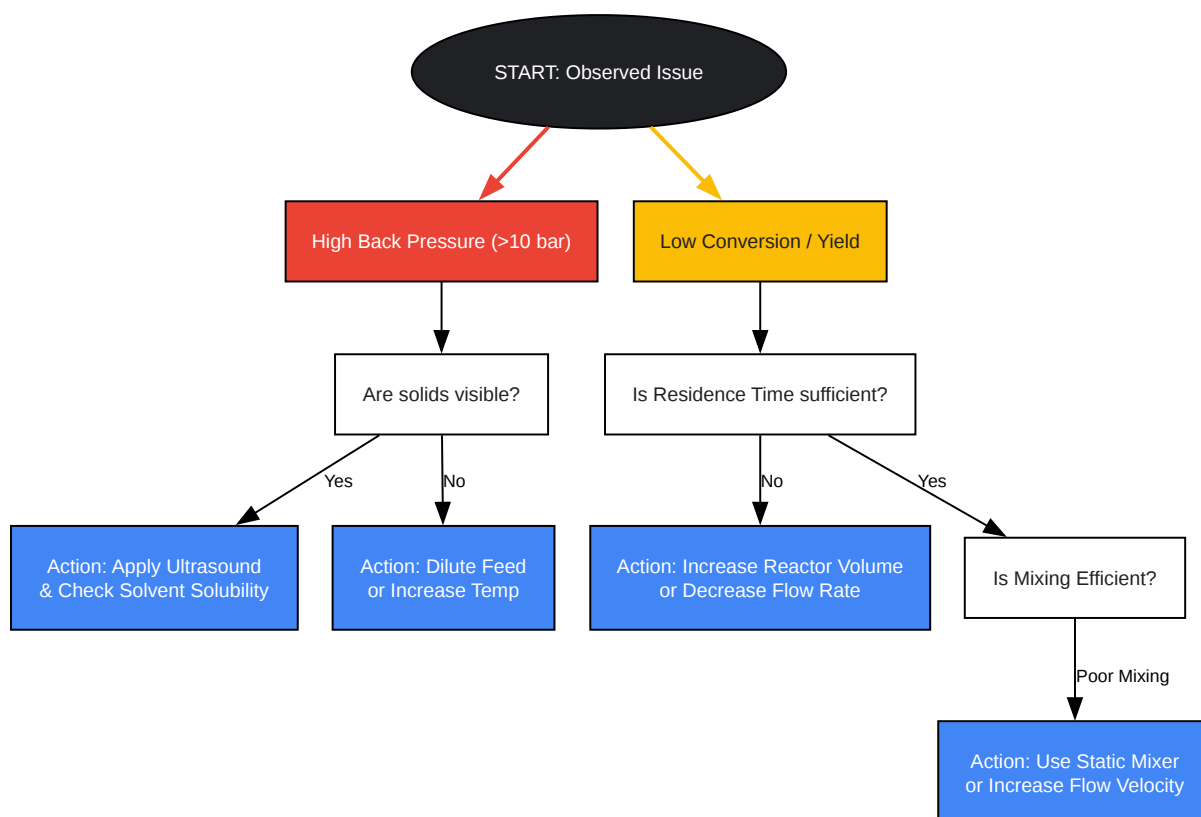

[Click to download full resolution via product page](#)

Figure 1: Decision matrix for diagnosing common flow chemistry failures. Red paths indicate safety/hardware critical issues; Yellow paths indicate chemical optimization.

## Cryogenic Lithiation Workflow Diagram

Visualizing the precise temperature zones required for successful C-H functionalization.

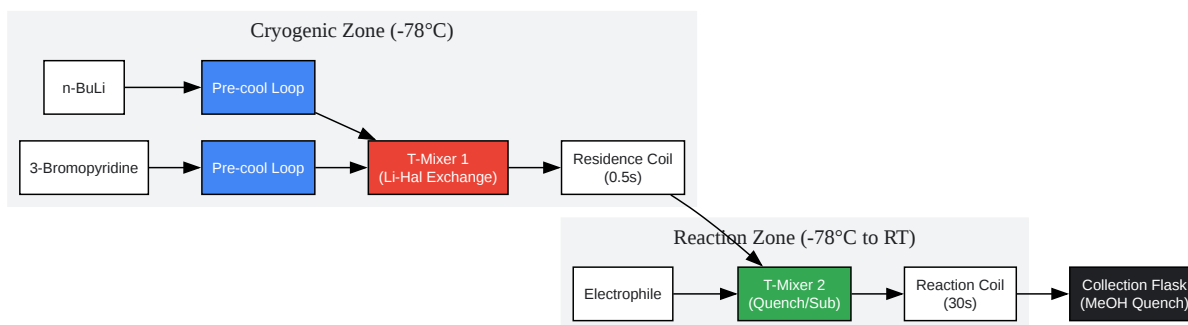

[Click to download full resolution via product page](#)

Figure 2: Schematic of a continuous flow lithiation setup. Note the short residence time in Zone 1 to prevent intermediate decomposition.

## Module 4: Advanced Photochemistry

Context: Photochemical synthesis of pyridines (e.g., via electrocyclization) benefits massively from flow due to the Beer-Lambert law—narrow channels ensure uniform irradiation.

### FAQ: Scaling Up Photochemistry

Q: I optimized a UV-mediated pyridine rearrangement on a 1 mL flow chip. When I moved to a 10 mL reactor coil, conversion dropped by 40%. Why?

A: You encountered the attenuation limit. In photochemistry, you cannot simply "size up" (increase diameter) because light penetration decreases exponentially with path length.

Solution: Numbering Up (Parallelization) Instead of using a wider tube (Sizing Up), use multiple narrow tubes in parallel or a longer tube with the same diameter.

- Optimum Path Length: Keep reactor ID < 1.0 mm for UV processes.
- Light Source: Ensure the LED intensity (

) scales with the increased surface area of the longer coil.

## References

- Hartman, R. L., et al. (2011). Decoupling chemical reaction and mixing rates in microfluidic systems. Lab on a Chip. [\[Link\]](#)
- Gutmann, B., et al. (2015).<sup>[1]</sup> Continuous-flow technology—a tool for the safe manufacturing of active pharmaceutical ingredients. Angewandte Chemie International Edition. [\[Link\]](#)
- Noël, T., et al. (2011). Connecting flow chemistry with solids: Ultrasound-assisted continuous-flow synthesis. Chemical Science. [\[Link\]](#)
- Power, M., et al. (2020). Organolithium Bases in flow chemistry: a review. Tetrahedron. [\[Link\]](#)

### Need Custom Synthesis?

BenchChem offers custom synthesis for rare earth carbides and specific isotopic labeling.

Email: [info@benchchem.com](mailto:info@benchchem.com) or [Request Quote Online](#).

## Sources

- 1. [triggered.stanford.clockss.org](https://triggered.stanford.clockss.org) [[triggered.stanford.clockss.org](https://triggered.stanford.clockss.org)]
- To cite this document: BenchChem. [Technical Support Center: Flow Chemistry Optimization for Pyridine Derivatives]. BenchChem, [2026]. [Online PDF]. Available at: [\[https://www.benchchem.com/product/b125030#flow-chemistry-optimization-for-pyridine-derivative-synthesis\]](https://www.benchchem.com/product/b125030#flow-chemistry-optimization-for-pyridine-derivative-synthesis)

### Disclaimer & Data Validity:

The information provided in this document is for Research Use Only (RUO) and is strictly not intended for diagnostic or therapeutic procedures. While BenchChem strives to provide accurate protocols, we make no warranties, express or implied, regarding the fitness of this product for every specific experimental setup.

**Technical Support:** The protocols provided are for reference purposes. Unsure if this reagent suits your experiment? [[Contact our Ph.D. Support Team for a compatibility check](#)]

**Need Industrial/Bulk Grade?** [Request Custom Synthesis Quote](#)

## BenchChem

Our mission is to be the trusted global source of essential and advanced chemicals, empowering scientists and researchers to drive progress in science and industry.

### Contact

Address: 3281 E Guasti Rd  
Ontario, CA 91761, United States  
Phone: (601) 213-4426  
Email: [info@benchchem.com](mailto:info@benchchem.com)