

Orthogonal Building Blocks: Architecting the Future of Medicinal Chemistry

Author: BenchChem Technical Support Team. **Date:** May 2026

Compound of Interest

Compound Name: *2-(Azidomethyl)-4-bromo-1-methoxybenzene*

Cat. No.: *B12497050*

[Get Quote](#)

As a Senior Application Scientist, my experience has consistently shown that the most profound advances in drug discovery are born not just from novel biological insights, but from the chemical tools that allow us to act on them with precision. The modular, predictable, and efficient assembly of complex, biologically active molecules is the central challenge of our field. This guide delves into the core principles and practical applications of orthogonal building blocks, a synthetic strategy that has fundamentally reshaped our ability to construct next-generation therapeutics.

The principle of orthogonality in chemistry refers to the ability to perform a specific chemical reaction or remove a particular protecting group in the presence of multiple other reactive functionalities without affecting them.[1][2] This concept allows for a stepwise, highly controlled synthesis of complex molecules, much like an architect using different, non-interfering construction methods for the foundation, frame, and facade of a building. In medicinal chemistry, this translates to unprecedented control over molecular design, enabling the rapid generation of compound libraries, the synthesis of intricate natural products, and the construction of sophisticated bioconjugates like antibody-drug conjugates (ADCs) and PROTACs (PROteolysis TArgeting Chimeras).[3][4]

This guide will explore the three pillars of this synthetic logic: orthogonal protecting groups that choreograph multi-step syntheses, bioorthogonal reactions that build bridges in complex biological environments, and orthogonally reactive linkers that enable the creation of multifunctional therapeutics.

Pillar 1: The Choreography of Synthesis with Orthogonal Protecting Groups

The foundation of orthogonal synthesis lies in the strategic use of protecting groups—molecular "scaffolding" that temporarily masks a reactive functional group.^[5] An ideal protecting group is stable under a specific set of reaction conditions but can be removed selectively under a different, non-interfering set of conditions.^[2] The power of this approach is most elegantly demonstrated in solid-phase peptide synthesis (SPPS), a cornerstone of drug discovery.

The two dominant strategies in SPPS, tert-butoxycarbonyl (Boc) and 9-fluorenylmethoxycarbonyl (Fmoc) chemistry, are built on this principle.^{[1][2]}

- **Boc/Benzyl (Bzl) Strategy:** This classic approach, pioneered by Merrifield, uses the acid-labile Boc group for N α -amino protection and different acid-labile groups like benzyl ethers for side-chain protection. Selectivity is achieved through differential acid sensitivity; the Boc group is removed by moderate acid (e.g., trifluoroacetic acid, TFA), while side-chain groups require a much stronger acid (e.g., hydrofluoric acid) for cleavage.^[6]
- **Fmoc/tert-Butyl (tBu) Strategy:** This is arguably the more common method today due to its milder conditions. The N α -amino group is protected by the base-labile Fmoc group, while side-chain functionalities are protected by acid-labile groups like tert-butyl (tBu) ethers, esters, and urethanes.^{[2][6]} This creates a truly orthogonal system: the Fmoc group can be removed repeatedly with a mild base (like piperidine) to extend the peptide chain, without affecting the acid-labile side-chain protectors. At the end of the synthesis, a strong acid (TFA) is used to remove all side-chain groups and cleave the peptide from its solid support.^{[1][6]}

The causality behind choosing one strategy over another depends on the desired final product. The Fmoc/tBu strategy avoids the use of harsh hydrofluoric acid, making it more suitable for fragile or complex peptides.^[1] The true power of orthogonality emerges when a third or even fourth layer of selectively removable protecting groups is introduced, allowing for site-specific modifications such as branching, cyclization, or the attachment of labels and payloads.^[2] For

example, an amino acid side chain can be protected with an ivDde group, which is stable to both the base used for Fmoc removal and the acid for tBu removal, but is selectively cleaved by hydrazine. This grants the chemist a specific, addressable point for modification mid-synthesis.

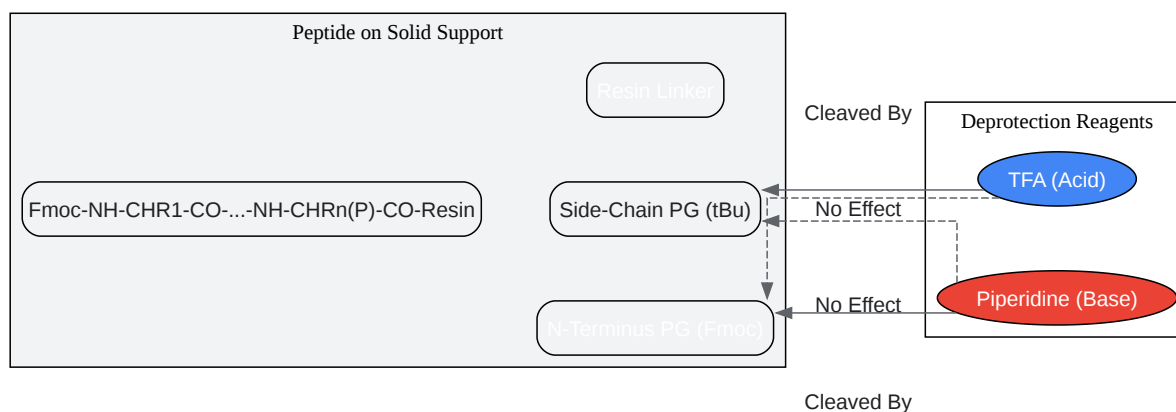

[Click to download full resolution via product page](#)

Caption: Orthogonal protecting groups in Fmoc/tBu solid-phase peptide synthesis.

Pillar 2: Bioorthogonal Chemistry: Building Molecules in the Presence of Life

While orthogonal protecting groups provide control in the flask, bioorthogonal chemistry extends this principle into the most complex environment imaginable: a living system.^{[7][8]} Coined by Carolyn Bertozzi, the term describes chemical reactions that can occur within a biological setting without interfering with or being affected by the native biochemical processes.^{[9][10][11]} This has revolutionized our ability to label, image, and manipulate biomolecules in real-time.^{[9][12]}

The most prominent family of bioorthogonal reactions falls under the umbrella of "click chemistry," a concept introduced by K. Barry Sharpless, Morten Meldal, and M.G. Finn.[13][14][15] Click chemistry emphasizes reactions that are modular, high-yielding, stereospecific, and generate only inoffensive byproducts, making them ideal for both drug discovery and biological applications.[13][15]

Key Bioorthogonal "Click" Reactions:

Reaction	Key Features	Typical Application Areas
CuAAC (Copper(I)-catalyzed Azide-Alkyne Cycloaddition)	The "gold standard" of click chemistry. Fast, reliable, and high-yielding. Forms a stable 1,2,3-triazole linkage.[13][14]	In vitro bioconjugation, materials science, drug library synthesis.[15]
SPAAC (Strain-promoted Azide-Alkyne Cycloaddition)	Catalyst-free version of CuAAC, avoiding copper toxicity. Uses strained alkynes (e.g., DBCO, BCN).[16][17]	Live-cell imaging, in vivo drug delivery, surface modification. [9][12]
IEDDA (Inverse-electron-demand Diels-Alder)	Extremely fast kinetics between a tetrazine and a strained alkene (e.g., trans-cyclooctene, TCO).[4][7]	Real-time imaging of low-abundance molecules, pre-targeted drug delivery.[8][16]

The causality for developing reactions like SPAAC and IEDDA was the need to move beyond the test tube. While CuAAC is exceptionally efficient, the cytotoxicity of the copper catalyst limits its use in living organisms.[4][17] SPAAC circumvents this by using ring strain in the alkyne partner to drive the reaction forward without a metal catalyst, making it a workhorse for live-cell labeling.[7][16] IEDDA reactions took this a step further, offering reaction rates orders of magnitude faster than SPAAC, which is critical for tracking rapid biological processes or targeting molecules present at very low concentrations.[4]

These reactions allow for a modular "two-part" strategy. First, a biomolecule of interest (like a cell-surface protein or a viral particle) is metabolically labeled with one functional group (e.g., an azide). Then, a second molecule carrying a probe or drug and the complementary functional

group (e.g., a strained alkyne) is introduced. The bioorthogonal reaction "clicks" the two together with high specificity, even amidst the complexity of the cellular milieu.[8][16]

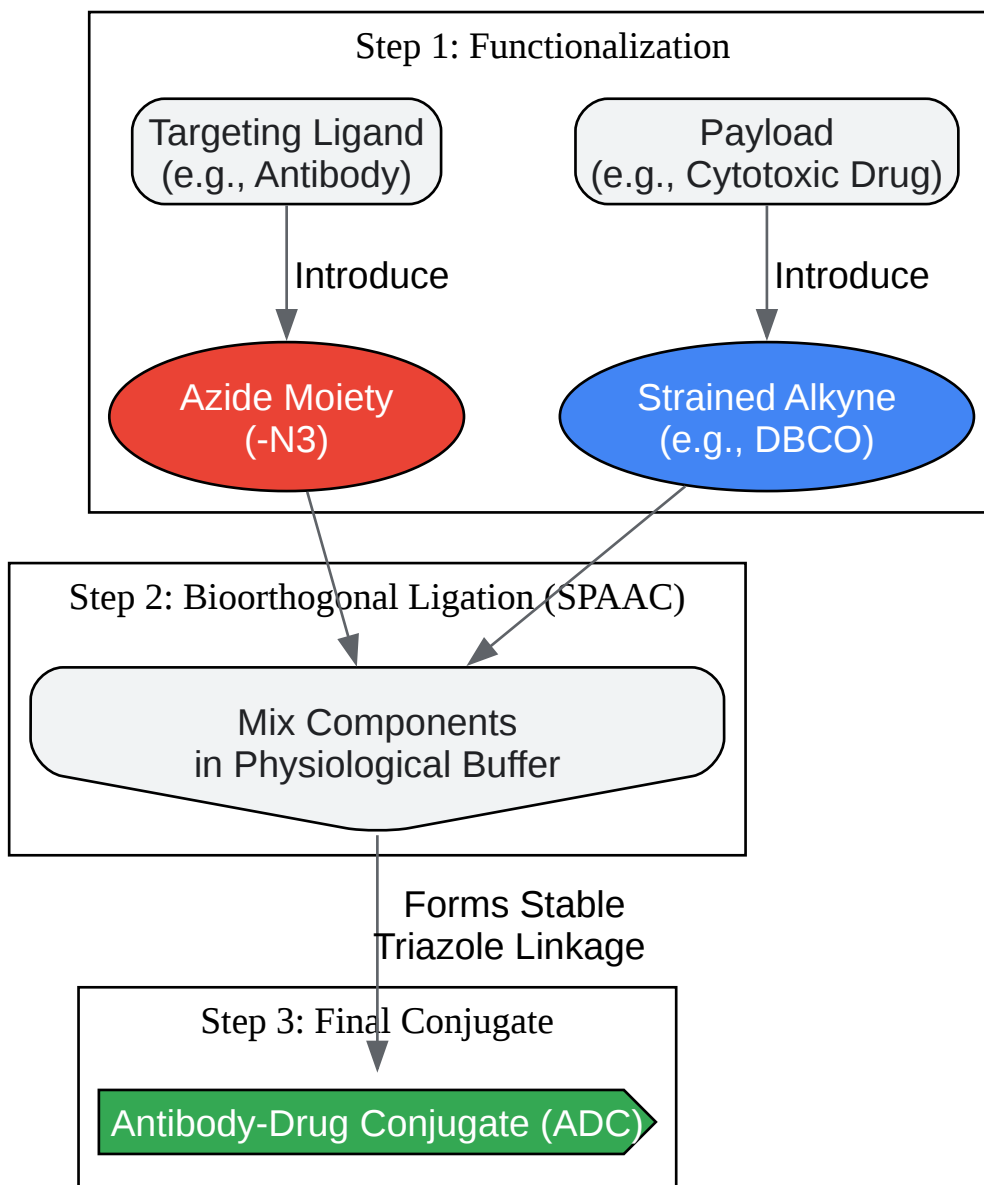

[Click to download full resolution via product page](#)

Caption: Workflow for creating an Antibody-Drug Conjugate using SPAAC.

Pillar 3: Orthogonally Reactive Linkers: The Key to Multifunctionality

Linkers are the critical connectors in many modern therapeutics, bridging targeting moieties to payloads.[18] Orthogonally reactive linkers take this a step further by incorporating multiple, selectively addressable chemical handles. This allows for the precise, stepwise construction of multifunctional molecules, a significant challenge in medicinal chemistry.[3][19]

This strategy is paramount in the development of complex modalities like PROTACs, which require three distinct components: a ligand for the protein of interest, a ligand for an E3 ligase, and a linker to connect them.[3] Using an orthogonal linker—for example, one bearing both an azide and a protected amine—allows a chemist to first attach the E3 ligase ligand via click chemistry, then deprotect the amine and attach the target protein ligand via standard amide coupling. This modularity enables the rapid synthesis of libraries where the linker length and composition can be systematically varied to optimize degradation activity.[3]

Furthermore, the linker itself can be designed to be "smart" through the incorporation of cleavable moieties.[18] These linkers are stable during circulation but are designed to break apart under specific conditions found at the target site, releasing the drug payload precisely where it is needed.

Types of Cleavable Linkers:

- **Photocleavable Linkers:** These contain a photoremovable protecting group (PPG), such as an *o*-nitrobenzyl or coumarin derivative, that cleaves upon exposure to light of a specific wavelength.[20][21][22] This offers exceptional spatiotemporal control over drug release, though it is often limited by the penetration depth of light in tissues.[20]
- **Enzymatically Cleavable Linkers:** These linkers are designed to be substrates for enzymes that are overexpressed in the target tissue, such as cathepsins in the tumor microenvironment.[18] A common example is the Valine-Citrulline (Val-Cit) linker used in several approved ADCs.
- **Chemically Cleavable Linkers:** These rely on the unique chemical environment of the target, such as the low pH of endosomes or the high reducing potential inside a cell. Disulfide linkers, for instance, are stable in the bloodstream but are readily cleaved by intracellular glutathione.[18]

The design of these linkers is a self-validating system: their cleavage and subsequent drug release are triggered only by the specific, pre-defined conditions of the target environment, thereby enhancing efficacy and minimizing off-target toxicity.[18][20]

Experimental Protocol: Strain-Promoted Azide-Alkyne Cycloaddition (SPAAC)

This protocol describes a general procedure for conjugating a DBCO-functionalized small molecule drug to an azide-functionalized antibody.

Materials & Reagents:

- Azide-functionalized antibody (Antibody-N3) in Phosphate-Buffered Saline (PBS), pH 7.4.
- DBCO-functionalized drug (Drug-DBCO) dissolved in DMSO.
- PBS, pH 7.4.
- Amicon Ultra centrifugal filter units (MWCO appropriate for the antibody).
- UV-Vis Spectrophotometer.

Methodology:

- Preparation of Reactants:
 - Determine the concentration of the Antibody-N3 solution using a spectrophotometer at 280 nm.
 - Prepare a 10 mM stock solution of Drug-DBCO in anhydrous DMSO.
- Conjugation Reaction:
 - In a microcentrifuge tube, add the Antibody-N3 solution.
 - Add a 5- to 10-fold molar excess of the Drug-DBCO stock solution to the antibody solution. The final concentration of DMSO should not exceed 10% (v/v) to maintain protein integrity.

- Gently mix the solution by pipetting and incubate at room temperature for 2-4 hours, or at 4°C for 12-18 hours. Protect the reaction from light if either component is light-sensitive.
- Purification of the Conjugate:
 - Following incubation, transfer the reaction mixture to an Amicon Ultra centrifugal filter unit.
 - Add PBS to bring the volume up to the filter's maximum capacity and centrifuge according to the manufacturer's instructions.
 - Discard the flow-through. This step removes unreacted Drug-DBCO and DMSO.
 - Repeat the wash step at least three times with fresh PBS to ensure complete removal of unconjugated drug.
- Characterization:
 - After the final wash, recover the purified Antibody-Drug Conjugate (ADC) from the filter unit.
 - Determine the final concentration of the ADC via A280 measurement.
 - Characterize the drug-to-antibody ratio (DAR) using techniques such as UV-Vis spectroscopy (if the drug has a unique absorbance), Hydrophobic Interaction Chromatography (HIC), or Mass Spectrometry.

Trustworthiness Check: The success of the protocol is validated by the characterization step. A successful conjugation will show a clear shift in the retention time on an HIC column or an increase in mass corresponding to the attached drug molecules in the mass spectrum, confirming the formation of the desired product.

Future Outlook and Challenges

The field of orthogonal chemistry continues to evolve at a rapid pace. A significant challenge is the development of a larger toolbox of mutually orthogonal reactions.^[23] While several bioorthogonal reactions exist, many are mechanistically similar and can cross-react.^[23] The ability to perform three or four distinct, non-interfering reactions in the same pot, whether in a

flask or a cell, would open up new frontiers in the synthesis of highly complex, multi-functional systems.^{[23][24]}

Furthermore, as these chemistries move closer to the clinic, issues of long-term stability, potential immunogenicity of the resulting linkages, and the pharmacokinetics of the building blocks themselves will require rigorous investigation.^{[15][17]} The combination of orthogonal chemistry with artificial intelligence and automated synthesis platforms promises to accelerate the discovery of novel therapeutics by navigating the vast chemical space of modular building blocks more efficiently than ever before.^{[15][24]}

By mastering the logic of orthogonality, medicinal chemists are no longer just synthesizing molecules; they are architecting them with a level of precision and modularity that will continue to drive the future of medicine.

References

- The Use of Click Chemistry in Drug Development Applic
- Bioorthogonal Click Chemistry for Imaging and Targeted Drug Delivery. Preprints.org.
- Click chemistry. Wikipedia. [\[Link\]](#)
- Orthogonal Protecting Groups for N(alpha)-amino and C-terminal Carboxyl Functions in Solid-Phase Peptide Synthesis. PubMed. [\[Link\]](#)
- Applications of Bioorthogonal Chemistry in Tumor-Targeted Drug Discovery. PubMed. [\[Link\]](#)
- Advances in click chemistry for drug discovery and development. Taylor & Francis Online. [\[Link\]](#)
- Breakthrough In Click Chemistry: Innovative Method Revolutionizes Drug Development. AZoM. [\[Link\]](#)
- Recent updates in click and computational chemistry for drug discovery and development. Frontiers. [\[Link\]](#)
- Bio-orthogonal Chemistry: Pioneering Therapeutic Precision in Medicine. Authorea. [\[Link\]](#)

- Orthogonal and safety-catch protecting group strategies in solid-phase peptide synthesis. ResearchGate. [\[Link\]](#)
- Bioorthogonal chemistry as a tool for prodrug activation and drug design. OUR Archive. [\[Link\]](#)
- Bio-orthogonal Chemistry: Pioneering Therapeutic Precision in Medicine. SpringerLink. [\[Link\]](#)
- Bioorthogonal Chemistry: Tools for Imaging and Drug Delivery. ResearchGate. [\[Link\]](#)
- Cutting-edge bioorthogonal chemistry: Innovations, practical applications, and emerging trends. European Journal of Chemistry. [\[Link\]](#)
- Development of Photoremovable Linkers as a Novel Strategy to Improve the Pharmacokinetics of Drug Conjugates and Their Potential Application in Antibody–Drug Conjugates for Cancer Therapy. PMC. [\[Link\]](#)
- Catch and Release: Designing Photocleavable Linkers for Attaching Antibodies (Abs) to Activated Polymeric Surfaces. University of Kansas. [\[Link\]](#)
- Protecting group. Wikipedia. [\[Link\]](#)
- Clicking in harmony: exploring the bio-orthogonal overlap in click chemistry. RSC Advances. [\[Link\]](#)
- Medicinal Chemistry in Review: Orthogonally Reactive Linkers and a D2B Approach: Discovery of a CNS Active GSK3 Degradar. Domainex. [\[Link\]](#)
- Synthesis of a photo-cleavable linker for selective drug delivery of ipomoeassin F. American Chemical Society. [\[Link\]](#)
- An Orthogonal Protection Strategy for Synthesizing Scaffold-Modifiable Dendrons and Their Application in Drug Delivery. ACS Central Science. [\[Link\]](#)
- A New Photocleavable Linker in Solid-Phase Chemistry for Ether Cleavage. Organic Letters. [\[Link\]](#)

- Bioorthogonal Chemistry in Translational Research: Advances and Opportunities. PubMed. [\[Link\]](#)
- Grand challenges in chemical biology from the perspective of organic chemical synthesis. Frontiers. [\[Link\]](#)
- Building Blocks for the Construction of Bioorthogonally Reactive Peptides via Solid-Phase Peptide Synthesis. VIVO. [\[Link\]](#)
- The Impact of Assay Design on Medicinal Chemistry: Case Studies. PubMed. [\[Link\]](#)
- Orthogonal synthesis of a versatile building block for dual functionalization of targeting vectors. ResearchGate. [\[Link\]](#)
- Constructing new bioorthogonal reagents and reactions. eScholarship.org. [\[Link\]](#)
- Orthogonal synthesis of a versatile building block for dual functionalization of targeting vectors. Erasmus University Rotterdam. [\[Link\]](#)

Need Custom Synthesis?

BenchChem offers custom synthesis for rare earth carbides and specific isotopic labeling.

Email: info@benchchem.com or [Request Quote Online](#).

Sources

- 1. Orthogonal protecting groups for N(alpha)-amino and C-terminal carboxyl functions in solid-phase peptide synthesis - PubMed [\[pubmed.ncbi.nlm.nih.gov\]](#)
- 2. bocsci.com [\[bocsci.com\]](#)
- 3. Medicinal Chemistry in Review: Orthogonally Reactive Linkers and a D2B Approach: Discovery of a CNS Active GSK3 Degradar | Domainex [\[domainex.co.uk\]](#)
- 4. chempep.com [\[chempep.com\]](#)
- 5. Protecting group - Wikipedia [\[en.wikipedia.org\]](#)
- 6. researchgate.net [\[researchgate.net\]](#)

- [7. Applications of Bioorthogonal Chemistry in Tumor-Targeted Drug Discovery - PubMed \[pubmed.ncbi.nlm.nih.gov\]](#)
- [8. pcbiochemres.com \[pcbiochemres.com\]](#)
- [9. eurjchem.com \[eurjchem.com\]](#)
- [10. Bioorthogonal Chemistry in Translational Research: Advances and Opportunities - PubMed \[pubmed.ncbi.nlm.nih.gov\]](#)
- [11. public-pages-files-2025.frontiersin.org \[public-pages-files-2025.frontiersin.org\]](#)
- [12. researchgate.net \[researchgate.net\]](#)
- [13. dergipark.org.tr \[dergipark.org.tr\]](#)
- [14. Click chemistry - Wikipedia \[en.wikipedia.org\]](#)
- [15. tandfonline.com \[tandfonline.com\]](#)
- [16. jocpr.com \[jocpr.com\]](#)
- [17. Frontiers | Recent updates in click and computational chemistry for drug discovery and development \[frontiersin.org\]](#)
- [18. Cleavable Linkers, protease cleavable, enzymatically cleavable | BroadPharm \[broadpharm.com\]](#)
- [19. researchgate.net \[researchgate.net\]](#)
- [20. Development of Photoremovable Linkers as a Novel Strategy to Improve the Pharmacokinetics of Drug Conjugates and Their Potential Application in Antibody–Drug Conjugates for Cancer Therapy - PMC \[pmc.ncbi.nlm.nih.gov\]](#)
- [21. chemreu.ku.edu \[chemreu.ku.edu\]](#)
- [22. pubs.acs.org \[pubs.acs.org\]](#)
- [23. escholarship.org \[escholarship.org\]](#)
- [24. Breakthrough In Click Chemistry: Innovative Method Revolutionizes Drug Development \[drugdiscoveryonline.com\]](#)
- [To cite this document: BenchChem. \[Orthogonal Building Blocks: Architecting the Future of Medicinal Chemistry\]. BenchChem, \[2026\]. \[Online PDF\]. Available at: \[https://www.benchchem.com/product/b12497050/docs#orthogonal-building-blocks-architecting-the-future-of-medicinal-chemistry\]](#)

Disclaimer & Data Validity:

The information provided in this document is for Research Use Only (RUO) and is strictly not intended for diagnostic or therapeutic procedures. While BenchChem strives to provide accurate protocols, we make no warranties, express or implied, regarding the fitness of this product for every specific experimental setup.

Technical Support: The protocols provided are for reference purposes. Unsure if this reagent suits your experiment?

Need Industrial/Bulk Grade? [Request Custom Synthesis Quote](#)

BenchChem

Our mission is to be the trusted global source of essential and advanced chemicals, empowering scientists and researchers to drive progress in science and industry.

Contact

Address: 3281 E Guasti Rd
Ontario, CA 91761, United States
Phone: (601) 213-4426
Email: info@benchchem.com

[Contact our Ph.D. Support Team for a compatibility check](#)