

dealing with contamination issues in 13-HOTrE analysis

Author: BenchChem Technical Support Team. **Date:** May 2026

Compound of Interest

Compound Name: 13-HoTrE

Cat. No.: B1249928

[Get Quote](#)

Technical Support Center: 13-HOTrE Analysis

This technical support center provides troubleshooting guidance and frequently asked questions (FAQs) for researchers, scientists, and drug development professionals working with 13-hydroxyoctadecatrienoic acid (**13-HOTrE**).

Frequently Asked Questions (FAQs)

Q1: What are the most common sources of contamination in **13-HOTrE** analysis?

A1: Contamination in **13-HOTrE** analysis can arise from various sources, broadly categorized as exogenous and endogenous.

- **Exogenous Contamination:** These are contaminants introduced from the external environment. Common sources include plasticizers (e.g., phthalates) from lab consumables like tubes and pipette tips, solvents, and reagents.[1][2] It is crucial to use high-purity solvents and glass or polypropylene containers to minimize this type of contamination.[2]
- **Endogenous Contamination (Matrix Effects):** These originate from the biological sample itself. Phospholipids are a major cause of matrix effects in plasma samples.[1] These

molecules can co-elute with **13-HOTrE** and suppress or enhance its ionization in the mass spectrometer, leading to inaccurate quantification.[1]

- Cross-Contamination: Carryover from previous samples in the autosampler or on the analytical column can lead to false-positive results.[3]

Q2: How can I differentiate **13-HOTrE** from its isomers, such as 9-HOTrE and 12-HOTrE?

A2: Differentiating positional isomers of HOTrE is a significant challenge because they have the same mass-to-charge ratio (m/z).[1] The most effective method for differentiation is tandem mass spectrometry (MS/MS).[1] Each isomer produces a unique fragmentation pattern upon collision-induced dissociation. By using Multiple Reaction Monitoring (MRM), specific precursor-to-product ion transitions can be targeted for each isomer, allowing for their individual quantification.[1] Chromatographic separation can also be optimized to resolve isomers, though this can be challenging due to their similar physicochemical properties.[1]

Q3: What is the role of an internal standard in **13-HOTrE** analysis, and which one should I use?

A3: An internal standard (IS) is essential for accurate and precise quantification of **13-HOTrE**. It is added to the sample at the beginning of the extraction process and helps to correct for variability in sample preparation and matrix effects.[1] The ideal internal standard is a stable isotope-labeled version of the analyte, such as **13-HOTrE-d4**. Since it has nearly identical chemical and physical properties to the endogenous **13-HOTrE**, it will behave similarly during extraction and ionization, providing the most accurate correction.[1]

Q4: What are the best practices for sample collection and storage to ensure **13-HOTrE** stability?

A4: Proper sample handling and storage are critical to prevent the degradation of **13-HOTrE**, which is prone to oxidation.[1]

- Collection: Collect blood samples in tubes containing an anticoagulant like EDTA or heparin. [4]
- Storage: Process samples as quickly as possible. For short-term storage, keep samples at 4°C. For long-term storage, plasma or serum should be stored at -80°C.[4][5] Avoid repeated

freeze-thaw cycles, as this can lead to analyte degradation.[4] The addition of an antioxidant, such as butylated hydroxytoluene (BHT), to the sample can help prevent auto-oxidation.[4]

Troubleshooting Guides

This section provides a systematic approach to resolving common issues encountered during **13-HOTrE** analysis.

Issue 1: Poor Peak Shape (Tailing, Broadening, or Splitting)

| Possible Cause | Troubleshooting Steps |
|---------------------------------|--|
| Column Contamination | Flush the column with a strong solvent. If the problem persists, replace the column. Install an in-line filter to protect the column from particulates.[6] |
| Inappropriate Injection Solvent | Ensure the injection solvent is weaker than or matches the initial mobile phase composition to avoid peak distortion.[6] |
| Column Overload | Reduce the injection volume or dilute the sample.[6] |
| Extra-column Effects | Minimize the length and diameter of tubing between the injector, column, and detector. Check for and correct any poor connections.[6] |

Issue 2: Low or No Signal for 13-HOTrE

| Possible Cause | Troubleshooting Steps |
|----------------------------------|--|
| Ion Suppression (Matrix Effect) | Perform a post-column infusion experiment to confirm ion suppression. Improve sample clean-up using solid-phase extraction (SPE) to remove interfering matrix components.[1] Modify the LC gradient to separate 13-HOTrE from the suppression zone. Utilize a stable isotope-labeled internal standard (e.g., 13-HOTrE-d4) to compensate for signal loss.[1] |
| Suboptimal Ion Source Parameters | Optimize ion source parameters such as gas flows, temperatures, and voltages for 13-HOTrE. A dirty ion source can also lead to poor ionization; regular cleaning is recommended.[1] |
| Analyte Degradation | Ensure proper sample collection and storage procedures were followed.[4] Prepare fresh samples and standards. |
| Incorrect MS/MS Transitions | Verify the precursor and product ion m/z values for 13-HOTrE. Optimize collision energy for the specific instrument being used.[4] |

Issue 3: High Background Noise or Presence of Contaminant Peaks

| Possible Cause | Troubleshooting Steps |
|-----------------------------------|---|
| Contaminated Solvents or Reagents | Use high-purity, LC-MS grade solvents and freshly prepared mobile phases.[3] |
| Leaching from Plastic Consumables | Use glass or certified low-binding polypropylene tubes and pipette tips. Run a blank (solvent injection) to identify potential contaminants from the system.[2] |
| Sample Carryover | Implement a rigorous needle wash protocol in the autosampler settings, using a strong solvent. Inject blank samples between experimental samples to check for carryover.[3] |
| Column Bleed | Condition the column according to the manufacturer's instructions. Ensure the mobile phase pH and temperature are within the column's operating limits. |

Experimental Protocols

Protocol 1: Liquid-Liquid Extraction (LLE) of **13-HOTrE** from Plasma

This protocol is adapted from established methods for the analysis of oxidized fatty acids.[4]

- Sample Preparation:
 - Thaw frozen plasma samples on ice.
 - In a glass tube, add 100 μ L of plasma.
 - Add 10 μ L of an antioxidant solution (e.g., 1 mg/mL BHT in methanol) and 10 μ L of the internal standard working solution (e.g., **13-HOTrE**-d4 at 500 ng/mL). Vortex briefly.
- Alkaline Hydrolysis (to measure total **13-HOTrE**):
 - Add 500 μ L of 1 M KOH in methanol.

- Incubate at 60°C for 30 minutes to release **13-HOTrE** from its esterified forms.
- Cool the tubes to room temperature.
- Neutralize the solution by adding approximately 1 mL of 1 M HCl in methanol until the pH is ~7.
- Extraction:
 - Add 2 mL of hexane to the tube.
 - Vortex vigorously for 3 minutes.
 - Centrifuge at 2,000 x g for 5 minutes to separate the phases.
 - Carefully transfer the upper hexane layer to a new clean glass tube.
 - Repeat the extraction with another 2 mL of hexane and combine the extracts.
- Dry Down and Reconstitution:
 - Evaporate the pooled hexane extract to dryness under a gentle stream of nitrogen.
 - Reconstitute the residue in 100 µL of the initial mobile phase (e.g., 60:40 Acetonitrile:Water).
 - Vortex and transfer to an LC autosampler vial for analysis.

Protocol 2: LC-MS/MS Parameters for 13-HOTrE Analysis

These are starting parameters and should be optimized for the specific instrument and column used.^[4]

| Parameter | Setting |
|-------------------------|--|
| LC Column | C18 reverse-phase column (e.g., 2.1 x 100 mm, 1.7 μ m) |
| Mobile Phase A | Water with 0.1% acetic acid or formic acid |
| Mobile Phase B | Acetonitrile/Methanol (e.g., 86:14 v/v) with 0.1% acetic acid |
| Flow Rate | 0.4 mL/min |
| Column Temperature | 50°C |
| Injection Volume | 10 μ L |
| Ionization Mode | Negative Electrospray Ionization (ESI-) |
| MS Analysis | Multiple Reaction Monitoring (MRM) |
| Example MRM Transitions | To be determined empirically for 13-HOTrE. For the similar compound 13-HODE, a common transition is m/z 311.2 -> 195.1.[1] |

Visualizations

Troubleshooting Workflow for Contamination Issues

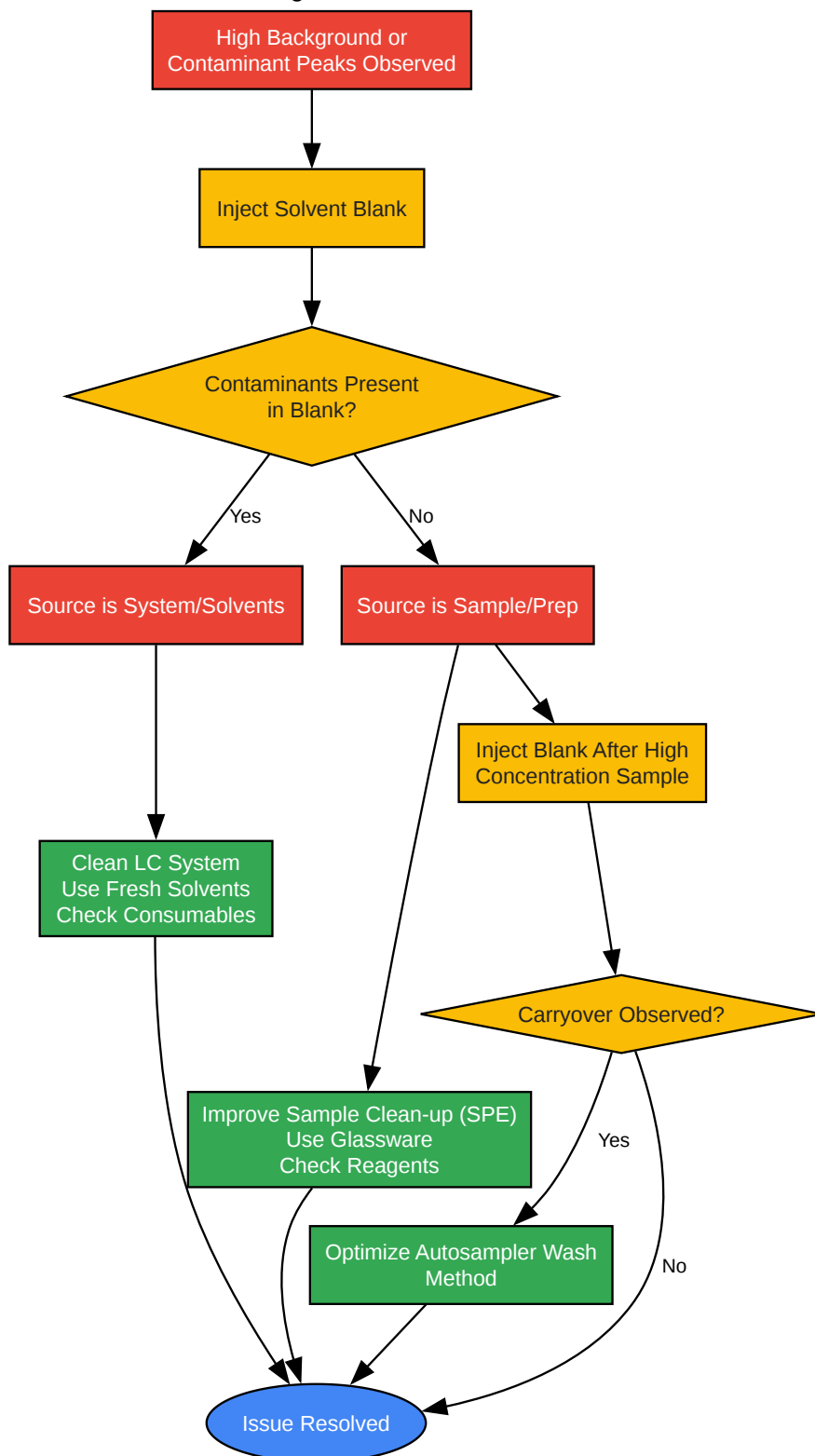

[Click to download full resolution via product page](#)

Caption: Troubleshooting workflow for contamination issues.

Experimental Workflow for 13-HOTrE Analysis

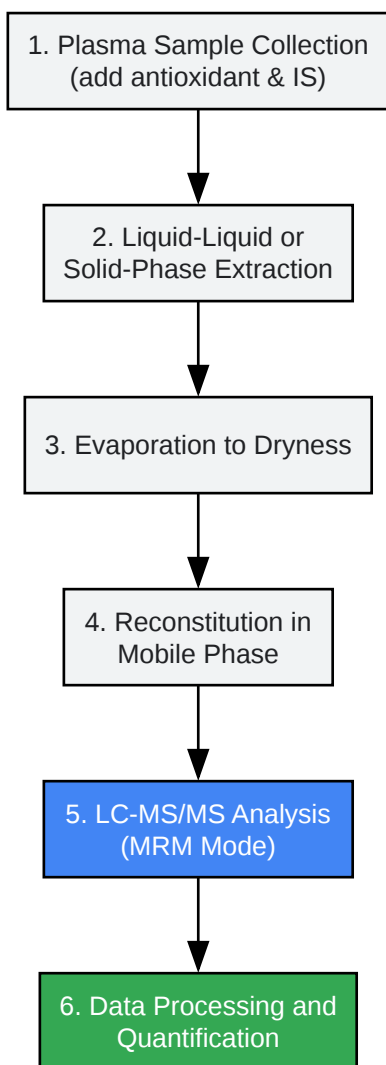

13-HOTrE Signaling Pathway

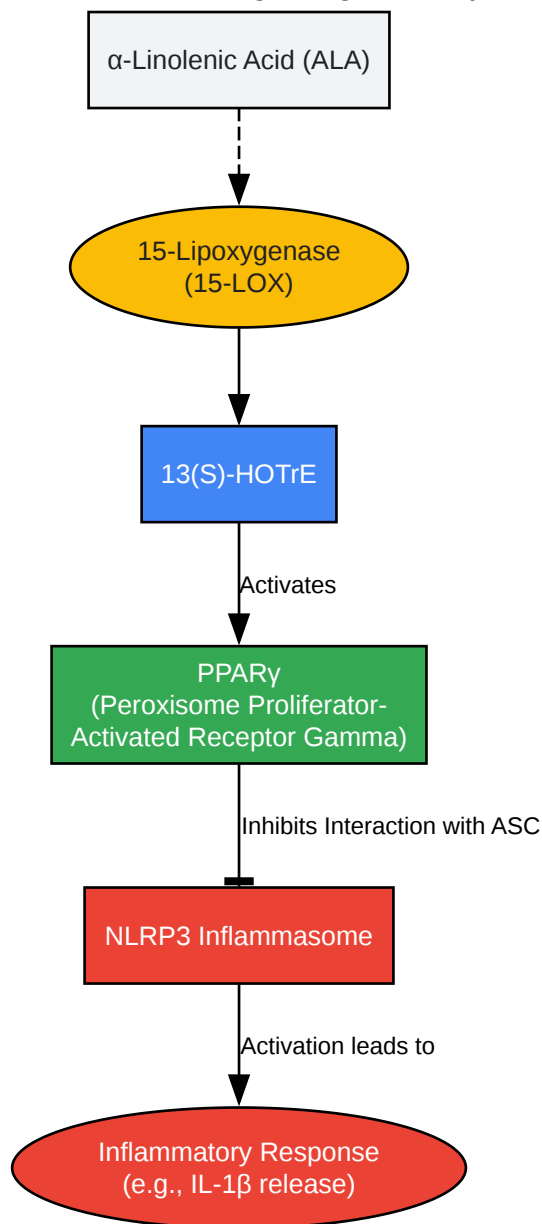

[Click to download full resolution via product page](#)

Need Custom Synthesis?

BenchChem offers custom synthesis for rare earth carbides and specific isotopic labeling.

Email: info@benchchem.com or [Request Quote Online](#).

References

- [1. benchchem.com \[benchchem.com\]](#)
- [2. Inhibitory effect of PPAR \$\gamma\$ on NLRP3 inflammasome activation - PubMed \[pubmed.ncbi.nlm.nih.gov\]](#)
- [3. benchchem.com \[benchchem.com\]](#)
- [4. 15-Lipoxygenase metabolites of \$\alpha\$ -linolenic acid, \[13-\(S\)-HPOTrE and 13-\(S\)-HOTrE\], mediate anti-inflammatory effects by inactivating NLRP3 inflammasome - PMC \[pmc.ncbi.nlm.nih.gov\]](#)
- [5. PPAR \$\gamma\$ signaling and metabolism: the good, the bad and the future - PMC \[pmc.ncbi.nlm.nih.gov\]](#)
- [6. High Sensitivity and Wide Linearity LC-MS/MS Method for Oxylipin Quantification in Multiple Biological Samples - PMC \[pmc.ncbi.nlm.nih.gov\]](#)
- [To cite this document: BenchChem. \[dealing with contamination issues in 13-HOTrE analysis\]. BenchChem, \[2026\]. \[Online PDF\]. Available at: \[https://www.benchchem.com/product/b1249928/docs#dealing-with-contamination-issues-in-13-hotre-analysis\]](#)

Disclaimer & Data Validity:

The information provided in this document is for Research Use Only (RUO) and is strictly not intended for diagnostic or therapeutic procedures. While BenchChem strives to provide accurate protocols, we make no warranties, express or implied, regarding the fitness of this product for every specific experimental setup.

Technical Support: The protocols provided are for reference purposes. Unsure if this reagent suits your experiment?

Need Industrial/Bulk Grade? [Request Custom Synthesis Quote](#)

BenchChem

Our mission is to be the trusted global source of essential and advanced chemicals, empowering scientists and researchers to drive progress in science and industry.

Contact

Address: 3281 E Guasti Rd

Ontario, CA 91761, United States

Phone: (601) 213-4426

Email: info@benchchem.com

Contact our Ph.D. Support Team for a compatibility check