

An In-depth Technical Guide to the Regulation of Actin Filament Turnover

Author: BenchChem Technical Support Team. **Date:** April 2026

Compound of Interest

Compound Name: *Actinc*
Cat. No.: *B1248410*

[Get Quote](#)

For Researchers, Scientists, and Drug Development Professionals

The actin cytoskeleton is a dynamic and essential component of eukaryotic cells, playing a pivotal role in a myriad of cellular processes including cell motility, morphogenesis, cytokinesis, and intracellular transport.[1][2] The continuous and rapid remodeling of actin filaments, a process known as actin turnover, is tightly regulated by a complex interplay of actin-binding proteins (ABPs) and signaling pathways.[3] This technical guide provides an in-depth overview of the core molecular machinery governing actin filament turnover, details key experimental methodologies used to study these dynamics, and presents quantitative data to facilitate comparative analysis.

Core Principles of Actin Filament Dynamics

Actin filaments (F-actin) are polymers of globular actin (G-actin) monomers. The intrinsic polarity of actin filaments, with a fast-growing "barbed" end and a slow-growing "pointed" end, is fundamental to their dynamic nature. The turnover of these filaments involves a coordinated cycle of polymerization and depolymerization, which is precisely controlled by a host of regulatory proteins.

Key Regulators of Actin Filament Turnover

The dynamic instability of the actin cytoskeleton is orchestrated by a diverse cast of actin-binding proteins, each with specific functions. These can be broadly categorized as follows:

- **Monomer-Binding Proteins:** These proteins regulate the pool of available G-actin for polymerization.
 - **Profilin:** Promotes actin polymerization by catalyzing the exchange of ADP for ATP on G-actin and delivering ATP-actin to the barbed end of growing filaments.[\[4\]](#)[\[5\]](#)
 - **Thymosin- β 4:** Sequesters ATP-G-actin, maintaining a pool of polymerization-competent monomers and preventing spontaneous nucleation.[\[6\]](#)[\[7\]](#)[\[8\]](#) The exchange between thymosin- β 4 and profilin for actin monomers is a key regulatory point.[\[6\]](#)[\[7\]](#)
- **Nucleating Proteins:** These proteins initiate the formation of new actin filaments.
 - **Arp2/3 Complex:** Creates branched, dendritic actin networks by nucleating new filaments off the sides of existing ones.[\[9\]](#)[\[10\]](#)[\[11\]](#)[\[12\]](#) This process is crucial for generating the protrusive force at the leading edge of motile cells.[\[10\]](#)[\[11\]](#)
 - **Formins:** Promote the nucleation and processive elongation of unbranched actin filaments.[\[9\]](#)[\[10\]](#)[\[11\]](#)[\[12\]](#) They remain associated with the barbed end, protecting it from capping proteins.[\[10\]](#)
- **Elongation and Capping Proteins:**
 - **Capping Protein (CP):** Binds to the barbed end of actin filaments with high affinity, preventing both the addition and loss of actin subunits.[\[13\]](#)[\[14\]](#)[\[15\]](#)[\[16\]](#)[\[17\]](#) This regulation of filament growth is critical for controlling the architecture of actin networks.[\[15\]](#)
 - **Ena/VASP Proteins:** Antagonize capping protein activity and promote the addition of actin monomers to the barbed end, effectively acting as anti-capping factors.[\[13\]](#)
- **Severing and Depolymerizing Proteins:**
 - **ADF/Cofilin Family:** These proteins are essential for rapid actin filament disassembly.[\[18\]](#) [\[19\]](#) They bind preferentially to ADP-actin filaments, inducing a conformational change that

leads to filament severing and enhanced depolymerization from the pointed end.[18][19][20][21]

- Cross-linking Proteins: These proteins organize actin filaments into higher-order structures such as bundles and networks. Examples include α -actinin and filamin.

Signaling Pathways Regulating Actin Turnover

The activities of these actin-binding proteins are spatiotemporally controlled by complex signaling networks, with the Rho family of small GTPases playing a central role.[22][23][24]

Rho GTPase Signaling

The classical Rho GTPases—RhoA, Rac1, and Cdc42—act as molecular switches, cycling between an active GTP-bound state and an inactive GDP-bound state.[22][25] This cycling is regulated by guanine nucleotide exchange factors (GEFs), GTPase-activating proteins (GAPs), and guanine nucleotide dissociation inhibitors (GDIs).[25]

- Cdc42: Primarily involved in the formation of filopodia and the activation of WASp/N-WASP proteins, which in turn activate the Arp2/3 complex.[26][27][28][29]
- Rac1: A key regulator of lamellipodia formation through the activation of the WAVE regulatory complex (WRC), which subsequently activates the Arp2/3 complex.[27][30]
- RhoA: Primarily controls the formation of stress fibers and focal adhesions, largely through its effectors ROCK and mDia (a formin).[23][25]

The diagram below illustrates the major signaling pathways from Rho GTPases to the actin cytoskeleton.

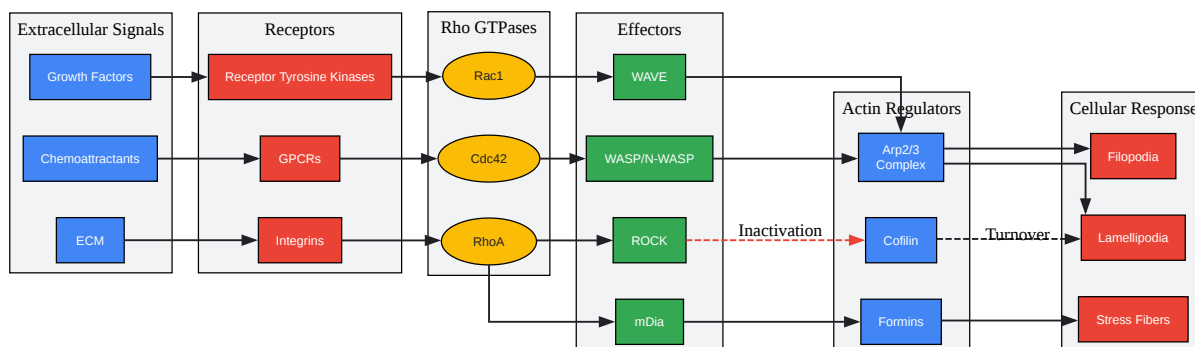

[Click to download full resolution via product page](#)

Caption: Rho GTPase signaling pathways controlling actin cytoskeleton dynamics.

Quantitative Data on Actin-Binding Proteins

The following tables summarize key quantitative parameters for various actin-binding proteins, providing a basis for comparative analysis.

Table 1: Monomer-Binding Protein Affinities

Protein	Ligand	Kd (μM)	Notes
Profilin I	ATP-G-actin	0.1	Also enhances nucleotide exchange. [5]
Profilin I	ADP-G-actin	0.17	
Thymosin-β4	ATP-G-actin	1	Sequesters actin monomers.[7]

Table 2: Capping and Depolymerizing Protein Activities

Protein	Activity	Kd	Rate	Notes
Capping Protein	Barbed End Capping	Sub-nanomolar	Dissociation t1/2 ~30 min (in vitro)	Tightly binds to prevent subunit addition/loss.[16][17]
ADF/Cofilin	F-actin Binding	Varies (cooperative)	-	Preferentially binds ADP-F-actin.[19]
ADF/Cofilin	Filament Severing	-	Concentration-dependent	Increases the number of filament ends.[18][21]

Table 3: Pharmacological Inhibitors of Actin Dynamics

Inhibitor	Mechanism of Action	Target
Cytochalasin D	Caps filament barbed ends	F-actin
Latrunculin A/B	Sequesters G-actin monomers	G-actin[1][31]
Jasplakinolide	Stabilizes F-actin by inhibiting disassembly	F-actin[1]
CK-666	Inhibits the Arp2/3 complex	Arp2/3 Complex[9][12]
SMIFH2	Inhibits formins	Formins[12]

Experimental Protocols for Studying Actin Turnover

A variety of in vitro and in vivo techniques are employed to dissect the mechanisms of actin dynamics. Below are detailed protocols for three key experimental approaches.

Pyrene-Actin Assembly Assay

This bulk fluorescence assay is used to monitor the kinetics of actin polymerization in vitro.[32] [33] It relies on the principle that the fluorescence of pyrene-labeled G-actin increases significantly upon its incorporation into F-actin.[33][34]

Methodology:

- Reagent Preparation:
 - Prepare G-buffer (e.g., 2 mM Tris-HCl pH 8.0, 0.2 mM ATP, 0.1 mM CaCl₂, 0.5 mM DTT). [35]
 - Prepare 10x polymerization buffer (e.g., 500 mM KCl, 20 mM MgCl₂, 10 mM ATP).
 - Prepare a stock of pyrene-labeled G-actin and unlabeled G-actin. A 5-10% pyrene-actin to unlabeled actin ratio is common.[36]
- Reaction Setup:
 - In a fluorometer cuvette or a 96-well plate, combine G-buffer, unlabeled G-actin, and pyrene-labeled G-actin to the desired final concentrations.
 - Add the protein of interest (e.g., a nucleator, capping protein, or sequestering protein) or a vehicle control.
- Initiation and Measurement:
 - Initiate polymerization by adding 1/10th the volume of 10x polymerization buffer.
 - Immediately begin recording fluorescence intensity over time using a fluorometer. Set the excitation wavelength to ~365 nm and the emission wavelength to ~407 nm.[33][35][36]
- Data Analysis:
 - Plot fluorescence intensity versus time. The resulting curve will show a lag phase (nucleation), a rapid increase (elongation), and a plateau (steady state).[33]
 - Analyze the kinetics by measuring the lag time, the maximum slope of the elongation phase (polymerization rate), and the final fluorescence intensity (total polymer mass).

The following diagram illustrates the workflow for a pyrene-actin assembly assay.

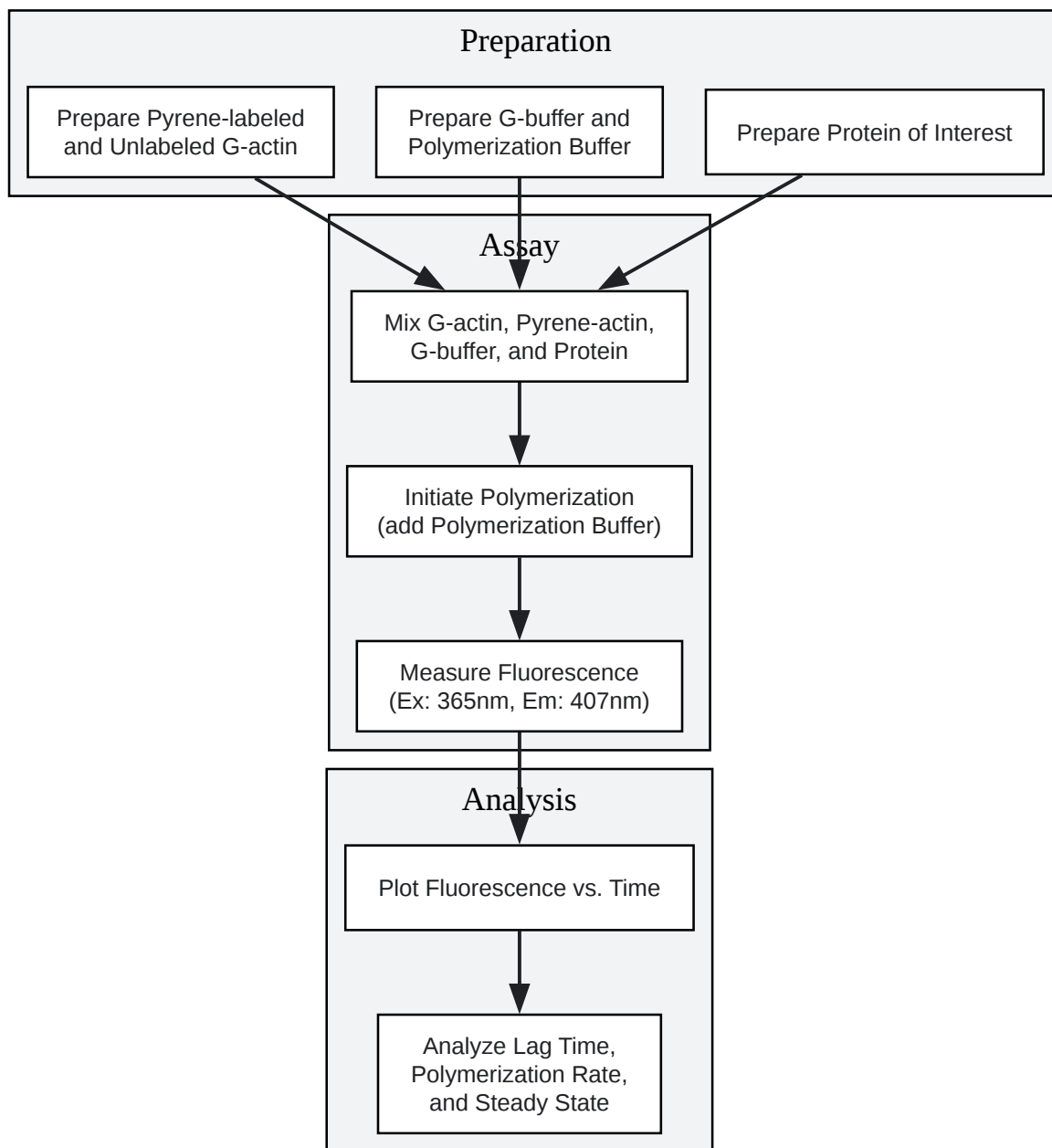

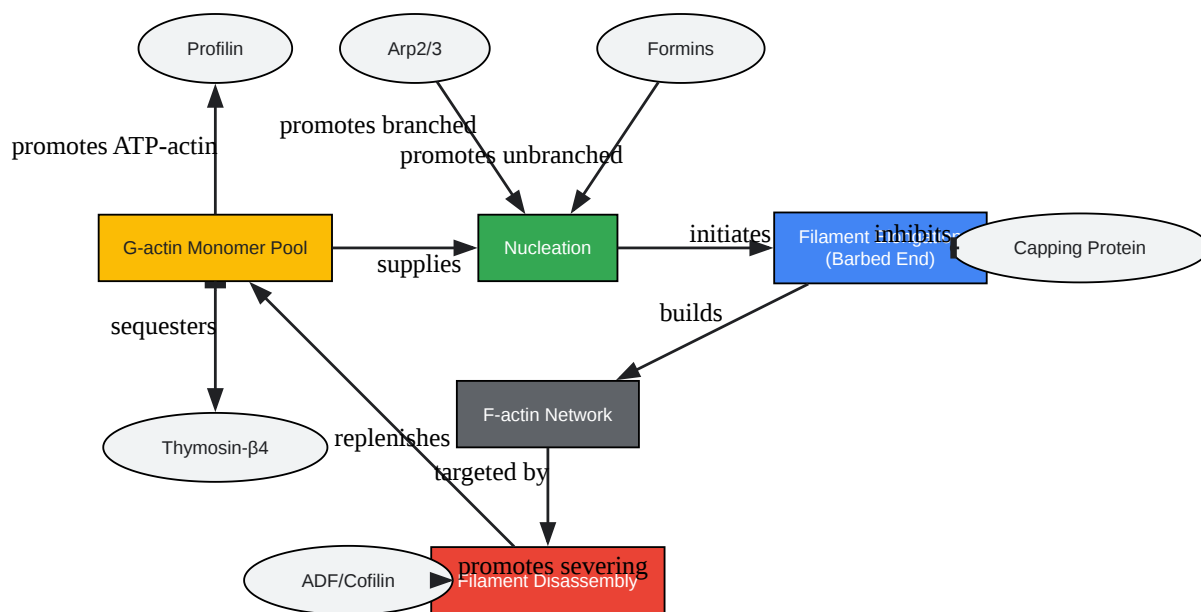

[Click to download full resolution via product page](#)

Need Custom Synthesis?

BenchChem offers custom synthesis for rare earth carbides and specific isotopic labeling.

Email: info@benchchem.com or [Request Quote Online](#).

References

- [1. A pharmacological cocktail for arresting actin dynamics in living cells - PMC \[pmc.ncbi.nlm.nih.gov\]](#)
- [2. Small-molecule inhibitors of actin dynamics and cell motility - PubMed \[pubmed.ncbi.nlm.nih.gov\]](#)
- [3. A pharmacological cocktail for arresting actin dynamics in living cells - PubMed \[pubmed.ncbi.nlm.nih.gov\]](#)

- [4. The control of actin nucleotide exchange by thymosin beta 4 and profilin. A potential regulatory mechanism for actin polymerization in cells - PMC \[pmc.ncbi.nlm.nih.gov\]](#)
- [5. Structural basis of thymosin-β4/profilin exchange leading to actin filament polymerization - PMC \[pmc.ncbi.nlm.nih.gov\]](#)
- [6. pnas.org \[pnas.org\]](#)
- [7. Structural basis of actin sequestration by thymosin-β4: implications for WH2 proteins - PMC \[pmc.ncbi.nlm.nih.gov\]](#)
- [8. Structural basis of thymosin-β4/profilin exchange leading to actin filament polymerization - PubMed \[pubmed.ncbi.nlm.nih.gov\]](#)
- [9. Cooperative actin filament nucleation by the Arp2/3 complex and formins maintains the homeostatic cortical array in Arabidopsis epidermal cells - PMC \[pmc.ncbi.nlm.nih.gov\]](#)
- [10. Regulation of actin filament assembly by Arp2/3 complex and formins - PubMed \[pubmed.ncbi.nlm.nih.gov\]](#)
- [11. Regulation of Actin Filament Assembly by Arp2/3 Complex and Formins | Annual Reviews \[annualreviews.org\]](#)
- [12. biorxiv.org \[biorxiv.org\]](#)
- [13. New Insights into Mechanism and Regulation of Actin Capping Protein - PMC \[pmc.ncbi.nlm.nih.gov\]](#)
- [14. New insights into mechanism and regulation of actin capping protein - PubMed \[pubmed.ncbi.nlm.nih.gov\]](#)
- [15. profiles.wustl.edu \[profiles.wustl.edu\]](#)
- [16. Capping Protein Regulators Fine-Tune Actin Assembly Dynamics - PMC \[pmc.ncbi.nlm.nih.gov\]](#)
- [17. Mechanism of actin capping protein recruitment and turnover during clathrin-mediated endocytosis - PMC \[pmc.ncbi.nlm.nih.gov\]](#)
- [18. ACTIN FILAMENT SEVERING BY COFILIN - PMC \[pmc.ncbi.nlm.nih.gov\]](#)
- [19. ADF/Cofilin Accelerates Actin Dynamics by Severing Filaments and Promoting Their Depolymerization at Both Ends - PMC \[pmc.ncbi.nlm.nih.gov\]](#)
- [20. Severing of F-actin by Yeast Cofilin is pH-Independent - PMC \[pmc.ncbi.nlm.nih.gov\]](#)
- [21. How cofilin severs an actin filament - PMC \[pmc.ncbi.nlm.nih.gov\]](#)
- [22. Rho GTPase Signaling: A Molecular Switchboard for Regulating the Actin Cytoskeleton in Axon Guidance - PubMed \[pubmed.ncbi.nlm.nih.gov\]](#)

- [23. geneglobe.qiagen.com \[geneglobe.qiagen.com\]](https://geneglobe.qiagen.com)
- [24. Regulation of the Actin Cytoskeleton via Rho GTPase Signalling in Dictyostelium and Mammalian Cells: A Parallel Slalom - PubMed \[pubmed.ncbi.nlm.nih.gov\]](https://pubmed.ncbi.nlm.nih.gov)
- [25. researchgate.net \[researchgate.net\]](https://researchgate.net)
- [26. WASP and SCAR/WAVE proteins: the drivers of actin assembly - PMC \[pmc.ncbi.nlm.nih.gov\]](https://pmc.ncbi.nlm.nih.gov)
- [27. WASP and WAVE family proteins: key molecules for rapid rearrangement of cortical actin filaments and cell movement - PubMed \[pubmed.ncbi.nlm.nih.gov\]](https://pubmed.ncbi.nlm.nih.gov)
- [28. journals.biologists.com \[journals.biologists.com\]](https://journals.biologists.com)
- [29. How Wasp Regulates Actin Polymerization - PMC \[pmc.ncbi.nlm.nih.gov\]](https://pmc.ncbi.nlm.nih.gov)
- [30. Regulation of the Actin Cytoskeleton via Rho GTPase Signalling in Dictyostelium and Mammalian Cells: A Parallel Slalom - PMC \[pmc.ncbi.nlm.nih.gov\]](https://pmc.ncbi.nlm.nih.gov)
- [31. scbt.com \[scbt.com\]](https://scbt.com)
- [32. Purification of Globular Actin from Rabbit Muscle and Pyrene Fluorescent Assays to Investigate Actin Dynamics in vitro - PMC \[pmc.ncbi.nlm.nih.gov\]](https://pmc.ncbi.nlm.nih.gov)
- [33. Actin polymerization assay | Andex \[andexbiotech.com\]](https://andexbiotech.com)
- [34. Pyrene actin prep \[maciverlab.bms.ed.ac.uk\]](https://maciverlab.bms.ed.ac.uk)
- [35. mullinslab.ucsf.edu \[mullinslab.ucsf.edu\]](https://mullinslab.ucsf.edu)
- [36. Cytoplasmic Actin: Purification and Single Molecule Assembly Assays - PMC \[pmc.ncbi.nlm.nih.gov\]](https://pmc.ncbi.nlm.nih.gov)
- To cite this document: BenchChem. [An In-depth Technical Guide to the Regulation of Actin Filament Turnover]. BenchChem, [2026]. [Online PDF]. Available at: [\[https://www.benchchem.com/product/b1248410/docs#an-in-depth-technical-guide-to-the-regulation-of-actin-filament-turnover\]](https://www.benchchem.com/product/b1248410/docs#an-in-depth-technical-guide-to-the-regulation-of-actin-filament-turnover)

Disclaimer & Data Validity:

The information provided in this document is for Research Use Only (RUO) and is strictly not intended for diagnostic or therapeutic procedures. While BenchChem strives to provide accurate protocols, we make no warranties, express or implied, regarding the fitness of this product for every specific experimental setup.

Technical Support: The protocols provided are for reference purposes. Unsure if this reagent suits your experiment?

Need Industrial/Bulk Grade? [Request Custom Synthesis Quote](#)

BenchChem

Our mission is to be the trusted global source of essential and advanced chemicals, empowering scientists and researchers to drive progress in science and industry.

Contact

Address: 3281 E Guasti Rd
Ontario, CA 91761, United States
Phone: (601) 213-4426
Email: info@benchchem.com

[Contact our Ph.D. Support Team for a compatibility check](#)