

Application Notes and Protocols for Radioligand Binding Assay Using [3H]CPCA

Author: BenchChem Technical Support Team. **Date:** April 2026

Compound of Interest

Compound Name: 5'-(N-Cyclopropyl)carboxamidoadenosine

Cat. No.: B1247455

[Get Quote](#)

For Researchers, Scientists, and Drug Development Professionals

Introduction

These application notes provide a detailed protocol for a radioligand binding assay using [3H]8-Cyclopentyl-1,3-dipropylxanthine ([3H]CPCA or [3H]DPCPX), a high-affinity and selective antagonist for the adenosine A1 receptor. Radioligand binding assays are a fundamental technique in pharmacology and drug discovery for characterizing receptor-ligand interactions. [1][2] This document outlines the procedures for both saturation and competition binding assays, enabling the determination of key receptor parameters such as receptor density (Bmax), ligand affinity (Kd), and the inhibitory constant (Ki) of unlabeled compounds.

The adenosine A1 receptor is a G protein-coupled receptor (GPCR) involved in various physiological processes, making it a significant target for therapeutic intervention.[3] Understanding the binding of novel compounds to this receptor is a critical step in the development of new drugs.

Adenosine A1 Receptor Signaling Pathway

Activation of the adenosine A1 receptor by an agonist initiates a signaling cascade through its coupling with inhibitory G proteins (Gi/o).[3] This leads to the inhibition of adenylyl cyclase, resulting in a decrease in intracellular cyclic AMP (camp) levels.[4][5] Additionally, the $\beta\gamma$ subunits of the dissociated G protein can modulate the activity of other effector proteins, including the activation of potassium channels and the inhibition of calcium channels.[3]

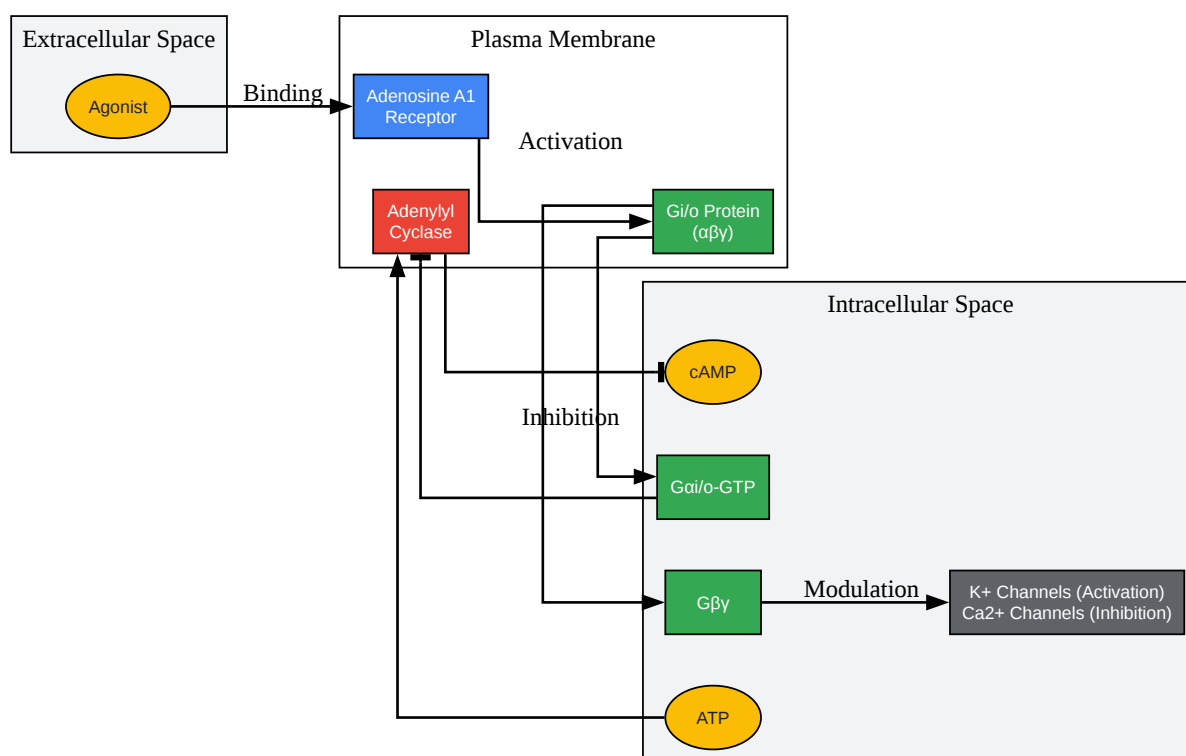

[Click to download full resolution via product page](#)

Caption: Adenosine A1 Receptor Signaling Pathway.

Experimental Protocols

Membrane Preparation from Tissues or Cells

This protocol describes the preparation of crude membrane fractions containing the adenosine A1 receptor.

Materials:

- Tissue (e.g., rat brain) or cultured cells expressing the adenosine A1 receptor
- Homogenization Buffer: 50 mM Tris-HCl, pH 7.4
- Centrifuge tubes
- Homogenizer (e.g., Dounce or Polytron)
- Refrigerated centrifuge

Procedure:

- Mince the tissue or collect the cell pellet.
- Add ice-cold Homogenization Buffer (10-20 volumes of the tissue weight or cell pellet volume).
- Homogenize the sample on ice.
- Centrifuge the homogenate at 1,000 x g for 10 minutes at 4°C to remove nuclei and large debris.
- Transfer the supernatant to a new tube and centrifuge at 40,000 x g for 30 minutes at 4°C to pellet the membranes.
- Discard the supernatant and resuspend the membrane pellet in fresh, ice-cold Homogenization Buffer.
- Repeat the centrifugation (step 5) and resuspension (step 6) steps one more time to wash the membranes.

- After the final centrifugation, resuspend the pellet in a small volume of Assay Buffer (see below) and determine the protein concentration using a standard method such as the Bradford or BCA assay.[6][7][8][9][10]
- Store the membrane preparation in aliquots at -80°C until use.

Saturation Binding Assay

This assay is performed to determine the receptor density (B_{max}) and the equilibrium dissociation constant (K_d) of the radioligand.[11]

Materials:

- Membrane preparation
- [3H]CPCA (Specific Activity: ~105 Ci/mmol)[12]
- Assay Buffer: 50 mM Tris-HCl, pH 7.4
- Non-specific binding determinator: 10 μM 8-Cyclopentyl-1,3-dipropylxanthine (unlabeled CPCA) or 1 mM Theophylline
- 96-well microplates
- Glass fiber filters (e.g., Whatman GF/C)
- Filtration apparatus (cell harvester)
- Scintillation vials
- Scintillation cocktail
- Liquid scintillation counter

Procedure:

- Prepare serial dilutions of [3H]CPCA in Assay Buffer. A typical concentration range would be 0.05 to 10 nM.

- In a 96-well plate, set up the following reactions in triplicate for each concentration of [3H]CPCA:
 - Total Binding: 50 μ L of [3H]CPCA dilution, 50 μ L of Assay Buffer, and 100 μ L of membrane preparation (typically 20-50 μ g of protein).
 - Non-specific Binding: 50 μ L of [3H]CPCA dilution, 50 μ L of non-specific binding determinator, and 100 μ L of membrane preparation.
- Incubate the plate at room temperature (25°C) for 60-90 minutes with gentle agitation.[\[13\]](#)
- Terminate the incubation by rapid filtration through glass fiber filters using a cell harvester.
- Wash the filters rapidly with 3 x 4 mL of ice-cold Assay Buffer to remove unbound radioligand.
- Transfer the filters to scintillation vials.
- Add 4-5 mL of scintillation cocktail to each vial and allow them to equilibrate in the dark for at least 4 hours.
- Measure the radioactivity in each vial using a liquid scintillation counter.
- Data Analysis:
 - Calculate specific binding by subtracting the non-specific binding from the total binding for each radioligand concentration.
 - Plot the specific binding (in fmol/mg protein) against the concentration of [3H]CPCA.
 - Analyze the data using non-linear regression to determine the Bmax and Kd values.

Competition Binding Assay

This assay is used to determine the affinity (K_i) of an unlabeled test compound for the receptor. [\[11\]](#)

Materials:

- Same as for the Saturation Binding Assay.
- Unlabeled test compound.

Procedure:

- Prepare serial dilutions of the unlabeled test compound in Assay Buffer.
- In a 96-well plate, set up the following reactions in triplicate:
 - Total Binding: 50 μ L of a fixed concentration of [3H]CPCA (typically at or near its K_d value, e.g., 1-2 nM), 50 μ L of Assay Buffer, and 100 μ L of membrane preparation.
 - Non-specific Binding: 50 μ L of [3H]CPCA, 50 μ L of non-specific binding determinator (e.g., 10 μ M unlabeled CPCA), and 100 μ L of membrane preparation.
 - Competition: 50 μ L of [3H]CPCA, 50 μ L of the unlabeled test compound dilution, and 100 μ L of membrane preparation.
- Follow steps 3-8 from the Saturation Binding Assay protocol.
- Data Analysis:
 - Plot the percentage of specific binding against the log concentration of the unlabeled test compound.
 - Use non-linear regression to determine the IC_{50} value (the concentration of the test compound that inhibits 50% of the specific binding of the radioligand).
 - Calculate the K_i value using the Cheng-Prusoff equation: $K_i = IC_{50} / (1 + ([L]/K_d))$, where [L] is the concentration of the radioligand used in the assay and K_d is the dissociation constant of the radioligand determined from the saturation binding assay.

Data Presentation

Table 1: Typical Parameters for [3H]CPCA Saturation Binding Assay

Parameter	Typical Value	Reference
Radioligand	[3H]CPCA ([3H]DPCPX)	[12]
Specific Activity	~105 Ci/mmol	[12]
Concentration Range	0.05 - 10 nM	-
Membrane Protein	20 - 50 μ g/well	[13]
Incubation Time	60 - 90 minutes	[13]
Incubation Temperature	25°C (Room Temperature)	[13]
Non-specific Ligand	10 μ M Unlabeled CPCA	-
Kd	0.5 - 5 nM	[14]
Bmax	Varies with tissue/cell type	-

Table 2: Typical Parameters for [3H]CPCA Competition Binding Assay

Parameter	Typical Value	Reference
Radioligand	[3H]CPCA ([3H]DPCPX)	[12]
[3H]CPCA Concentration	1 - 2 nM (at or near Kd)	-
Membrane Protein	20 - 50 μ g/well	[13]
Incubation Time	60 - 90 minutes	[13]
Incubation Temperature	25°C (Room Temperature)	[13]
Non-specific Ligand	10 μ M Unlabeled CPCA	-

Experimental Workflow

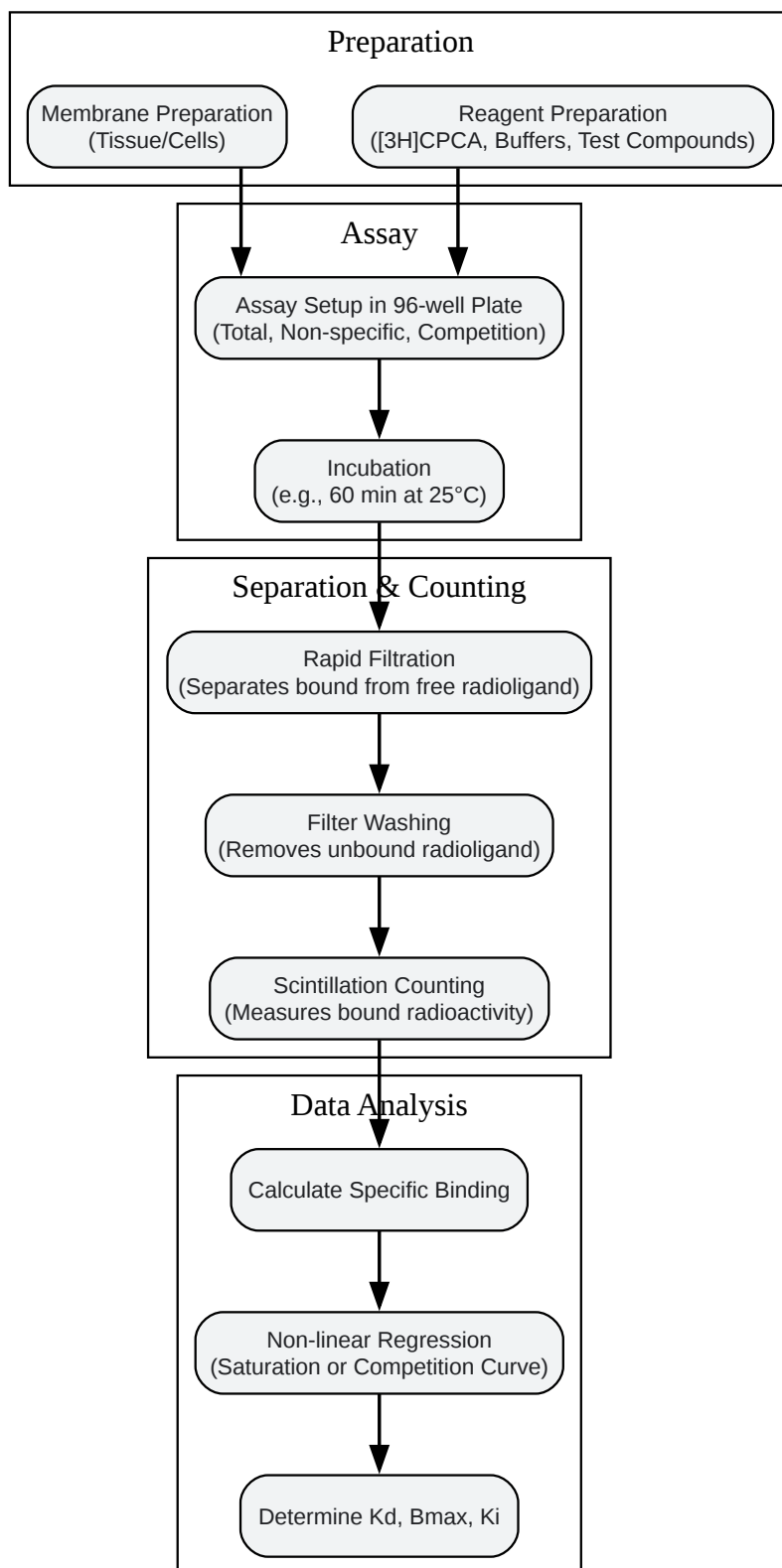

[Click to download full resolution via product page](#)

Caption: Radioligand Binding Assay Workflow.

Need Custom Synthesis?

BenchChem offers custom synthesis for rare earth carbides and specific isotopic labeling.

Email: info@benchchem.com or [Request Quote Online](#).

References

- [1. tandfonline.com](https://www.tandfonline.com) [tandfonline.com]
- [2. creative-diagnostics.com](https://www.creative-diagnostics.com) [creative-diagnostics.com]
- [3. Adenosine A1 receptor - Wikipedia](https://en.wikipedia.org) [en.wikipedia.org]
- [4. researchgate.net](https://www.researchgate.net) [researchgate.net]
- [5. researchgate.net](https://www.researchgate.net) [researchgate.net]
- [6. tools.thermofisher.com](https://tools.thermofisher.com) [tools.thermofisher.com]
- [7. biocev.lf1.cuni.cz](https://biocev.lf1.cuni.cz) [biocev.lf1.cuni.cz]
- [8. documents.thermofisher.com](https://documents.thermofisher.com) [documents.thermofisher.com]
- [9. 2024.sci-hub.se](https://2024.sci-hub.se) [2024.sci-hub.se]
- [10. Protein Assay Data Analysis | Thermo Fisher Scientific - HK](https://www.thermofisher.com) [thermofisher.com]
- [11. G-Protein-Coupled Receptors Signaling to MAPK/Erk | Cell Signaling Technology](https://www.cellsignal.com) [cellsignal.com]
- [12. 8-Cyclopentyl-1,3-dipropylxanthine \(DPCPX\)--a selective high affinity antagonist radioligand for A1 adenosine receptors - PubMed](https://pubmed.ncbi.nlm.nih.gov) [pubmed.ncbi.nlm.nih.gov]
- [13. storage.imrpress.com](https://storage.imrpress.com) [storage.imrpress.com]
- [14. Probing the Binding Site of the A1 Adenosine Receptor Reengineered for Orthogonal Recognition by Tailored Nucleosides - PMC](https://pmc.ncbi.nlm.nih.gov) [pmc.ncbi.nlm.nih.gov]
- To cite this document: BenchChem. [Application Notes and Protocols for Radioligand Binding Assay Using [³H]CPCA]. BenchChem, [2026]. [Online PDF]. Available at: [\[https://www.benchchem.com/product/b1247455/docs#application-notes-and-protocols-for-radioligand-binding-assay-using-3h-cpca\]](https://www.benchchem.com/product/b1247455/docs#application-notes-and-protocols-for-radioligand-binding-assay-using-3h-cpca)

Disclaimer & Data Validity:

The information provided in this document is for Research Use Only (RUO) and is strictly not intended for diagnostic or therapeutic procedures. While BenchChem strives to provide accurate protocols, we make no warranties, express or implied, regarding the fitness of this product for every specific experimental setup.

Technical Support: The protocols provided are for reference purposes. Unsure if this reagent suits your experiment?

Need Industrial/Bulk Grade? [Request Custom Synthesis Quote](#)

BenchChem

Our mission is to be the trusted global source of essential and advanced chemicals, empowering scientists and researchers to drive progress in science and industry.

Contact

Address: 3281 E Guasti Rd
Ontario, CA 91761, United States
Phone: (601) 213-4426
Email: info@benchchem.com

[Contact our Ph.D. Support Team for a compatibility check](#)