

# Application Notes and Protocols for the N-Alkylation of Substituted Hydrazines

**Author:** BenchChem Technical Support Team. **Date:** April 2026

## Compound of Interest

Compound Name:	{{2-(Benzyloxy)phenyl}methyl}hydrazine
CAS No.:	887594-34-5
Cat. No.:	B12451147

[Get Quote](#)

## Abstract

The N-alkylation of substituted hydrazines is a cornerstone of synthetic organic chemistry, pivotal to the development of novel pharmaceuticals, agrochemicals, and functional materials. Substituted hydrazine moieties are integral components of numerous biologically active molecules, including treatments for tuberculosis, Parkinson's disease, and hypertension.[1] This guide provides a comprehensive overview of contemporary and classical methods for the N-alkylation of hydrazines, offering detailed experimental protocols, mechanistic insights, and practical guidance for researchers, scientists, and drug development professionals. We delve into direct alkylation strategies, reductive amination techniques, and catalytic approaches using alcohols, providing a robust framework for procedural selection and optimization.

## Introduction: The Significance of N-Alkyl Hydrazines

Hydrazine derivatives are a critical class of compounds in medicinal chemistry and organic synthesis.[1][2] Their unique structural and electronic properties make them valuable

precursors for a wide array of heterocyclic compounds and peptidomimetics.[2] The ability to selectively introduce alkyl groups onto the nitrogen atoms of a hydrazine scaffold allows for the fine-tuning of a molecule's physicochemical properties, such as lipophilicity, metabolic stability, and target-binding affinity. However, the synthesis of substituted hydrazines can be challenging due to issues of selectivity, as the two nitrogen atoms can have similar reactivity, and the potential for over-alkylation.[3] This document aims to provide a clear and detailed guide to navigating these challenges.

## Mechanistic Considerations and Strategic Approaches

The approach to N-alkylation of hydrazines is dictated by the desired substitution pattern (mono-, di-, tri-, or tetra-substituted) and the nature of the starting hydrazine (e.g., hydrazine hydrate, arylhydrazine, acylhydrazide). The primary methods can be broadly categorized as direct alkylation, reductive alkylation, and catalytic alkylation with alcohols.

### Direct N-Alkylation with Alkyl Halides

This classical approach involves the reaction of a hydrazine with an alkyl halide in the presence of a base. The choice of base and solvent is critical for controlling the degree and regioselectivity of alkylation. For acylhydrazides, direct N,N-dialkylation can be achieved using a stoichiometric amount of a strong base followed by treatment with an alkyl halide.[4]

A more sophisticated strategy for selective alkylation involves the formation of a nitrogen dianion using a strong base like n-butyllithium (n-BuLi).[1][5] This method allows for sequential and selective alkylation of either nitrogen atom by carefully controlling the stoichiometry of the reagents.[1][5]

General Reaction Scheme for Direct N-Alkylation

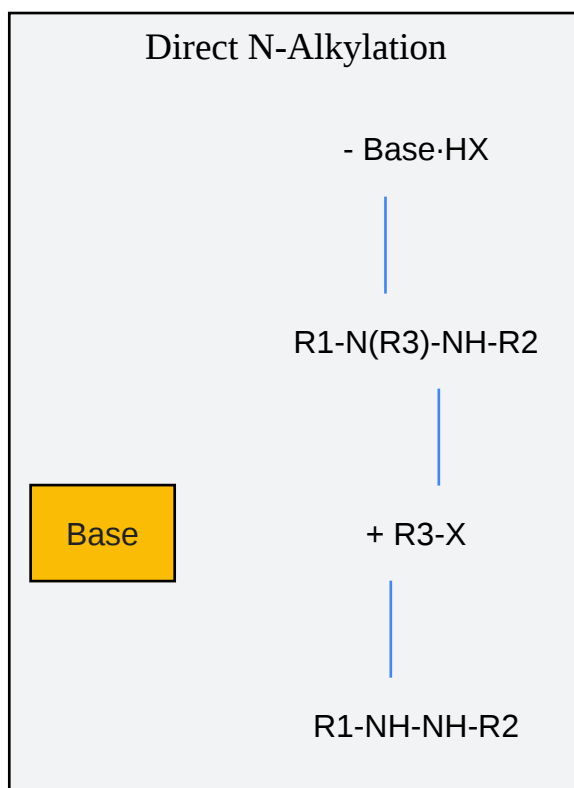

[Click to download full resolution via product page](#)

Caption: General workflow for direct N-alkylation of a substituted hydrazine.

## Reductive Alkylation (Reductive Amination)

Reductive alkylation is a powerful and often milder alternative to direct alkylation. This one-pot procedure typically involves the condensation of a hydrazine with an aldehyde or ketone to form a hydrazone intermediate, which is then reduced in situ to the corresponding N-alkylated hydrazine.[6] This method offers high chemoselectivity and is compatible with a wide range of functional groups.[3]

Various catalytic systems have been developed to facilitate this transformation, including:

- Arylboronic acids: These catalysts can promote the tandem reduction of azoarenes to hydrazoarenes, followed by reductive alkylation with an aldehyde.[3]
- Hexafluoroisopropanol (HFIP): This solvent can promote the catalyst-free reductive alkylation of azoarenes.

- Enzymes: Imine reductases (IREDs) have been successfully employed for the reductive amination of carbonyls with hydrazines.[6]
- Trichlorosilane with Lewis bases: This system provides a facile synthesis of 1,1-disubstituted hydrazines.[7]

#### Reductive Alkylation Workflow

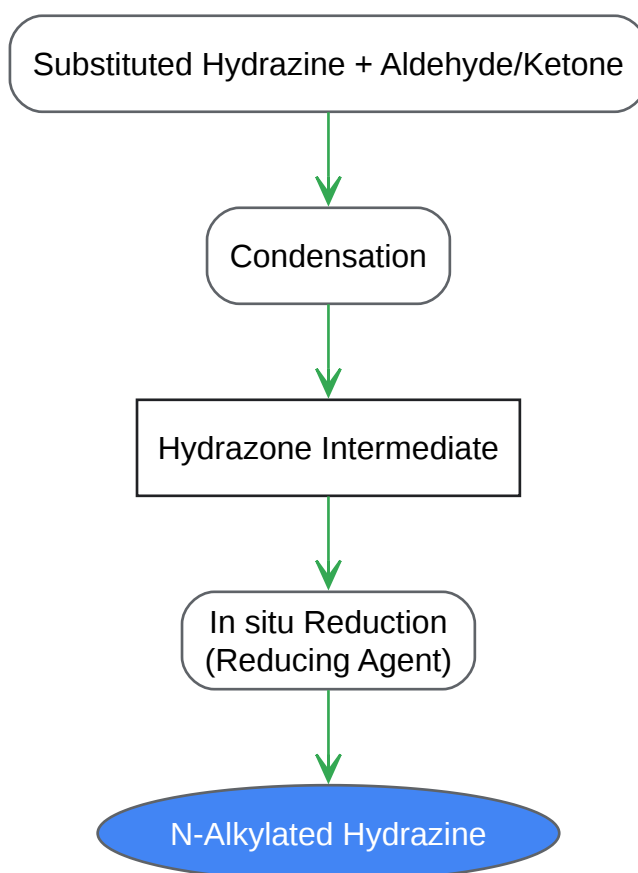

[Click to download full resolution via product page](#)

Caption: Stepwise process of reductive alkylation of hydrazines.

## Catalytic N-Alkylation Using Alcohols

An environmentally benign approach to N-alkylation involves the use of alcohols as alkylating agents, with water being the only byproduct.[8][9] These reactions are typically catalyzed by transition metal complexes (e.g., Ruthenium or Nickel) and proceed via a "borrowing hydrogen" mechanism.[8][10] The catalyst temporarily "borrows" hydrogen from the alcohol to form a

metal-hydride species and an aldehyde intermediate. The aldehyde then condenses with the hydrazine to form a hydrazone, which is subsequently reduced by the metal-hydride to yield the N-alkylated product and regenerate the catalyst.

## Detailed Experimental Protocols

### Protocol 1: Selective Mono-alkylation of a Protected Hydrazine via Dianion Formation

This protocol is adapted from the work of Bredihhin, Groth, and Mäeorg and is suitable for the selective alkylation of a protected hydrazine.<sup>[1][5][11]</sup>

#### Materials:

- N-Boc-N'-phenylhydrazine
- Anhydrous Tetrahydrofuran (THF)
- n-Butyllithium (n-BuLi) in hexanes (2.5 M)
- Alkyl halide (e.g., benzyl bromide)
- Saturated aqueous ammonium chloride (NH<sub>4</sub>Cl) solution
- Ethyl acetate
- Brine
- Anhydrous sodium sulfate (Na<sub>2</sub>SO<sub>4</sub>)

#### Equipment:

- Round-bottom flask
- Magnetic stirrer
- Syringes
- Septa

- Nitrogen or Argon inert atmosphere setup
- Low-temperature bath (e.g., dry ice/acetone)

Procedure:

- To a flame-dried round-bottom flask under an inert atmosphere, add N-Boc-N'-phenylhydrazine (1.0 eq) and anhydrous THF.
- Cool the solution to -78 °C in a dry ice/acetone bath.
- Slowly add n-BuLi (2.0 eq) dropwise via syringe. The formation of the dianion is often indicated by a color change.<sup>[1]</sup>
- Stir the mixture at -78 °C for 30 minutes.
- Slowly add the alkyl halide (1.0 eq) dropwise at -78 °C.
- Allow the reaction to slowly warm to room temperature and stir for 2-4 hours, monitoring the reaction progress by Thin Layer Chromatography (TLC).<sup>[1]</sup>
- Upon completion, cool the reaction to 0 °C and carefully quench by the slow addition of saturated aqueous NH<sub>4</sub>Cl solution.
- Extract the aqueous layer with ethyl acetate (3x).
- Combine the organic layers, wash with brine, dry over anhydrous Na<sub>2</sub>SO<sub>4</sub>, and filter.
- Concentrate the solvent under reduced pressure and purify the crude product by silica gel column chromatography.

## Protocol 2: Reductive Alkylation of an Acylhydrazide with an Aldehyde

This protocol is a general procedure based on the principles of reductive amination.

Materials:

- Acylhydrazide (e.g., benzohydrazide)
- Aldehyde (e.g., benzaldehyde)
- Methanol
- Sodium borohydride ( $\text{NaBH}_4$ ) or a similar reducing agent
- Glacial acetic acid (catalytic amount)
- Dichloromethane (DCM)
- Saturated aqueous sodium bicarbonate ( $\text{NaHCO}_3$ ) solution
- Brine
- Anhydrous magnesium sulfate ( $\text{MgSO}_4$ )

#### Equipment:

- Round-bottom flask
- Magnetic stirrer
- Reflux condenser (if heating is required)

#### Procedure:

- Dissolve the acylhydrazide (1.0 eq) and the aldehyde (1.1 eq) in methanol in a round-bottom flask.
- Add a catalytic amount of glacial acetic acid.
- Stir the mixture at room temperature for 1-2 hours to allow for the formation of the hydrazone intermediate.
- Cool the reaction mixture to 0 °C in an ice bath.
- Slowly and portion-wise add sodium borohydride (1.5 eq).

- After the addition is complete, remove the ice bath and stir the reaction at room temperature for an additional 2-4 hours, or until the reaction is complete as monitored by TLC.
- Quench the reaction by the slow addition of water.
- Concentrate the mixture under reduced pressure to remove most of the methanol.
- Partition the residue between DCM and saturated aqueous NaHCO<sub>3</sub> solution.
- Separate the layers and extract the aqueous layer with DCM (2x).
- Combine the organic layers, wash with brine, dry over anhydrous MgSO<sub>4</sub>, and filter.
- Concentrate the filtrate to yield the crude product, which can be further purified by recrystallization or column chromatography.

## Summary of Reaction Conditions

The choice of reaction conditions is paramount for achieving the desired N-alkylated hydrazine product with high yield and selectivity. The following table summarizes various approaches and their key parameters.

Method	Substrate	Alkylating Agent	Catalyst/ Reagent	Solvent	Key Features	Reference
Direct Alkylation	N-Boc-N'-phenylhydrazine	Alkyl Halides	n-BuLi	THF	Selective mono- or di-alkylation via dianion formation.	[1][5]
Direct Alkylation	Acylhydrazides	Alcohols	Ruthenium Pincer Complex, KOtBu	Toluene	Environmentally friendly, produces water as the only byproduct.	[8][9]
Reductive Alkylation	Azoarenes	Aldehydes	Arylboronic Acid	-	Mild conditions, high chemoselectivity.	[3]
Reductive Alkylation	Azoarenes	Aldehydes	Hexafluoroisopropanol (HFIP)	HFIP	Catalyst-free, suppresses N-N bond cleavage.	
Reductive Alkylation	Ketones/Aldehydes	Phenylhydrazines	HMPA, Trichlorosilane	DCM	Good for 1,1-disubstituted hydrazines.	[7]
Enzymatic Reductive Hydrazination	Carbonyls	Hydrazines	Imine Reductase (IRED)	Buffer	High selectivity, potential for chirality.	[6]

## Safety Precautions

Working with hydrazine and its derivatives requires strict adherence to safety protocols due to their potential toxicity and reactivity.[\[12\]](#)[\[13\]](#)[\[14\]](#)

- **Handling:** Always handle hydrazine and its derivatives in a well-ventilated chemical fume hood.[\[12\]](#)[\[15\]](#) Wear appropriate personal protective equipment (PPE), including chemical-resistant gloves (inspect before use), safety goggles, a face shield, and a lab coat.[\[12\]](#)[\[13\]](#) Avoid inhalation of vapors and direct skin contact.[\[12\]](#)[\[16\]](#)
- **Storage:** Store hydrazine derivatives in tightly sealed containers in a cool, dry, and well-ventilated area, away from heat, sparks, and incompatible materials such as strong oxidizing agents and acids.[\[14\]](#)[\[15\]](#)[\[16\]](#)
- **Spills:** In case of a spill, evacuate the area and remove all sources of ignition.[\[12\]](#)[\[15\]](#) Absorb the spill with an inert material (e.g., sand or vermiculite) and place it in a sealed container for proper disposal.[\[12\]](#) Do not flush spills into the sewer system.[\[12\]](#)[\[15\]](#)
- **First Aid:** In case of skin contact, immediately wash the affected area with plenty of water for at least 15 minutes.[\[12\]](#)[\[13\]](#) For eye contact, rinse immediately with plenty of water and seek medical advice.[\[12\]](#) If inhaled, move to fresh air and seek immediate medical attention.[\[12\]](#) If swallowed, do NOT induce vomiting and seek immediate medical attention.[\[12\]](#)

## Troubleshooting

Issue	Potential Cause(s)	Suggested Solution(s)
Low or no product yield	Inactive catalyst; poor quality reagents; incorrect reaction temperature; insufficient reaction time.	Use fresh, high-purity reagents and solvents. Optimize reaction temperature and time. For catalytic reactions, ensure the catalyst is active.
Over-alkylation	Base is too strong or used in excess; reactive alkylating agent.	Use a milder base or a stoichiometric amount. Add the alkylating agent slowly at a lower temperature. Consider using a protecting group strategy.
Formation of side products (e.g., N-N bond cleavage)	Harsh reaction conditions (high temperature, strong acid/base).	Employ milder reaction conditions. Reductive amination methods often suppress N-N cleavage.[3]
Poor regioselectivity	Similar reactivity of the two nitrogen atoms.	Use a protecting group to differentiate the two nitrogen atoms. The dianion strategy can offer excellent regioselectivity.[1][5]

## Conclusion

The N-alkylation of substituted hydrazines is a versatile and indispensable transformation in modern organic synthesis. The choice of methodology, from classical direct alkylation to modern catalytic and enzymatic approaches, allows for the synthesis of a vast array of structurally diverse hydrazine derivatives. A thorough understanding of the underlying mechanisms, careful selection of reaction conditions, and strict adherence to safety protocols are essential for successful outcomes. This guide provides a foundational framework to assist researchers in navigating the complexities of hydrazine alkylation and in developing robust and efficient synthetic routes for their target molecules.

## References

- R. A. S. and H. G. G. SYNTHESIS OF 1,2-DIALKYLHYDRAZINES AND THE CORRESPONDING AZOALKANES. Canadian Journal of Chemistry.
- Arylboronic Acid Catalyzed Reductive Alkylation of Azoarenes to N-Alkylated Hydrazines. Chemistry.
- Perdicchia, D. Ionic hydrogenation of azines: An efficient synthesis of 1,2-dialkylhydrazines. AIR Unimi.
- Synthesis of Substituted Acyclic and Cyclic N-Alkylhydrazines by Enzymatic Reductive Hydrazinations. PMC. Available at: [\[Link\]](#)
- Thiyagarajan, S. and Gunanathan, C. Direct Catalytic Symmetrical, Unsymmetrical N,N-Dialkylation and Cyclization of Acylhydrazides Using Alcohols. Organic Chemistry Portal. Available at: [\[Link\]](#)
- Thiyagarajan, S. and Gunanathan, C. (2020). Direct Catalytic Symmetrical, Unsymmetrical N,N-Dialkylation and Cyclization of Acylhydrazides Using Alcohols. PubMed. Available at: [\[Link\]](#)
- Bredihhin, A., Groth, U. M., and Mäeorg, U. Efficient Methodology for Selective Alkylation of Hydrazine Derivatives. Organic Chemistry Portal. Available at: [\[Link\]](#)
- Alkylation of N-acyl hydrazones. Isolated yields are shown. ResearchGate. Available at: [\[Link\]](#)
- Bredihhin, A., Groth, U. M., and Ma1eorg, U. Efficient Methodology for Selective Alkylation of Hydrazine Derivatives. Organic Letters. Available at: [\[Link\]](#)
- Reductive alkylation of azoarenes to N -alkylated hydrazines enabled by hexafluoroisopropanol. Chemical Communications (RSC Publishing). Available at: [\[Link\]](#)
- R. A. S. and H. G. G. SYNTHESIS OF 1,2-DIALKYLHYDRAZINES AND THE CORRESPONDING AZOALKANES. Canadian Science Publishing. Available at: [\[Link\]](#)
- Hydrazine hydrate - SAFETY DATA SHEET. Fisher Scientific. Available at: [\[Link\]](#)
- The preparation of 1,2-diacyl-2- (t-alkyl) hydrazines. Google Patents.

- Efficient Copper-Catalyzed Selective Synthesis of 1,1-Diaryl Hydrazines from Aryl Boronic Acids and. Chemical Methodologies. Available at: [\[Link\]](#)
- Ligand-assisted nickel catalysis enabling N,N-dialkylation and cyclization of acyl hydrazides using aliphatic alcohols. RSC Publishing. Available at: [\[Link\]](#)
- Safety and Handling of Hydrazine. DTIC. Available at: [\[Link\]](#)
- Possible mechanism of N-alkylation of hydrazine catalyzed by Ir complex. ResearchGate. Available at: [\[Link\]](#)
- Construction of Trisubstituted Hydrazones via Base-Mediated Cascade Condensation N-Alkylation. The Journal of Organic Chemistry - ACS Publications. Available at: [\[Link\]](#)
- Expedient tandem dehydrogenative alkylation and cyclization reactions under Mn(I)-catalysis. RSC Publishing. Available at: [\[Link\]](#)
- Synthetic methodology for alkyl substituted hydrazines. ResearchGate. Available at: [\[Link\]](#)
- Synthesis of 1,3,4-oxadiazoles from 1,2-diacylhydrazines using [Et<sub>2</sub>NSF<sub>2</sub>]<sup>+</sup>BF<sub>4</sub><sup>-</sup> as a practical cyclodehydration agent. Organic & Biomolecular Chemistry (RSC Publishing). Available at: [\[Link\]](#)
- Amine synthesis by reductive amination (reductive alkylation). Organic Chemistry Portal. Available at: [\[Link\]](#)
- A general and selective Ni-catalysed reductive amination using hydrazine hydrate as facile hydrogen and nitrogen sources. ResearchGate. Available at: [\[Link\]](#)
- Synthetic methodology for alkyl substituted hydrazines. Chemical Society Reviews (RSC Publishing). Available at: [\[Link\]](#)
- Photocatalytic Radical Addition to N-Sulfonyl Hydrazones as a C–H Alkylation Strategy. Thieme. Available at: [\[Link\]](#)
- Synthesis of Hydrazine Derivatives (Hydrazides). Organic Chemistry Portal. Available at: [\[Link\]](#)

- Hydrazine derivative synthesis by trifluoroacetyl hydrazide alkylation. Canadian Journal of Chemistry. Available at: [\[Link\]](#)
- Switching N-Alkylation Regioselectivity of Trifluoromethylated Pyrazoles Guided by Functional Group Tuning. PMC. Available at: [\[Link\]](#)
- Potassium iodide catalysis in the alkylation of protected hydrazines. EAP - Estonian Academy Publishers. Available at: [\[Link\]](#)
- Efficient Copper-Catalyzed Selective Synthesis of 1,1-Diaryl Hydrazines from Aryl Boronic Acids and Hydrazine Hydrate. ResearchGate. Available at: [\[Link\]](#)
- Reductive Hydrazination with Trichlorosilane: A Method for the Preparation of 1,1-Disubstituted Hydrazines. Organic Chemistry Portal. Available at: [\[Link\]](#)
- Reductive N-alkylation of primary and secondary amines using carboxylic acids and borazane under mild conditions. Organic Chemistry Frontiers (RSC Publishing). Available at: [\[Link\]](#)
- Intermolecular Alkyne Hydroaminations Involving 1,1-Disubstituted Hydrazines. ResearchGate. Available at: [\[Link\]](#)
- Synthesis of hydrazine and azapeptide derivatives by alkylation of carbazates and semicarbazones. ResearchGate. Available at: [\[Link\]](#)
- Reductive alkylation of azoarenes to N-alkylated hydrazines enabled by hexafluoroisopropanol. Chemical Communications (RSC Publishing). Available at: [\[Link\]](#)
- Efficient methodology for selective alkylation of hydrazine derivatives. PubMed. Available at: [\[Link\]](#)

### Need Custom Synthesis?

BenchChem offers custom synthesis for rare earth carbides and specific isotopic labeling.

Email: [info@benchchem.com](mailto:info@benchchem.com) or [Request Quote Online](#).

## Sources

- [1. d-nb.info \[d-nb.info\]](http://d-nb.info)
- [2. air.unimi.it \[air.unimi.it\]](http://air.unimi.it)
- [3. Arylboronic Acid Catalyzed Reductive Alkylation of Azoarenes to N-Alkylated Hydrazines - PubMed \[pubmed.ncbi.nlm.nih.gov\]](#)
- [4. researchgate.net \[researchgate.net\]](http://researchgate.net)
- [5. Efficient Methodology for Selective Alkylation of Hydrazine Derivatives \[organic-chemistry.org\]](#)
- [6. Synthesis of Substituted Acyclic and Cyclic N-Alkylhydrazines by Enzymatic Reductive Hydrazinations - PMC \[pmc.ncbi.nlm.nih.gov\]](#)
- [7. Reductive Hydrazination with Trichlorosilane: A Method for the Preparation of 1,1-Disubstituted Hydrazines \[organic-chemistry.org\]](#)
- [8. Direct Catalytic Symmetrical, Unsymmetrical N,N-Dialkylation and Cyclization of Acylhydrazides Using Alcohols \[organic-chemistry.org\]](#)
- [9. Direct Catalytic Symmetrical, Unsymmetrical N,N-Dialkylation and Cyclization of Acylhydrazides Using Alcohols - PubMed \[pubmed.ncbi.nlm.nih.gov\]](#)
- [10. Expedient tandem dehydrogenative alkylation and cyclization reactions under Mn\( i \)-catalysis - Catalysis Science & Technology \(RSC Publishing\) DOI:10.1039/D3CY00009E \[pubs.rsc.org\]](#)
- [11. Efficient methodology for selective alkylation of hydrazine derivatives - PubMed \[pubmed.ncbi.nlm.nih.gov\]](#)
- [12. fishersci.co.uk \[fishersci.co.uk\]](http://fishersci.co.uk)
- [13. files.dep.state.pa.us \[files.dep.state.pa.us\]](http://files.dep.state.pa.us)
- [14. apps.dtic.mil \[apps.dtic.mil\]](http://apps.dtic.mil)
- [15. assets.thermofisher.cn \[assets.thermofisher.cn\]](http://assets.thermofisher.cn)
- [16. datasheets.scbt.com \[datasheets.scbt.com\]](http://datasheets.scbt.com)
- To cite this document: BenchChem. [Application Notes and Protocols for the N-Alkylation of Substituted Hydrazines]. BenchChem, [2026]. [Online PDF]. Available at: [<https://www.benchchem.com/product/b12451147/docs#application-notes-and-protocols-for-the-n-alkylation-of-substituted-hydrazines>]

**Disclaimer & Data Validity:**

The information provided in this document is for Research Use Only (RUO) and is strictly not intended for diagnostic or therapeutic procedures. While BenchChem strives to provide accurate protocols, we make no warranties, express or implied, regarding the fitness of this product for every specific experimental setup.

**Technical Support:** The protocols provided are for reference purposes. Unsure if this reagent suits your experiment?

**Need Industrial/Bulk Grade?** [Request Custom Synthesis Quote](#)

## BenchChem

Our mission is to be the trusted global source of essential and advanced chemicals, empowering scientists and researchers to drive progress in science and industry.

### Contact

Address: 3281 E Guasti Rd  
Ontario, CA 91761, United States  
Phone: (601) 213-4426  
Email: [info@benchchem.com](mailto:info@benchchem.com)

[Contact our Ph.D. Support Team for a compatibility check](#)