

Application Note & Protocols for the Synthesis of Phthalazinones Using Substituted Hydrazines

Author: BenchChem Technical Support Team. **Date:** April 2026

Compound of Interest

Compound Name:	{{2-(Benzyloxy)phenyl}methyl}hydrazine
CAS No.:	887594-34-5
Cat. No.:	B12451147

[Get Quote](#)

Introduction: The Significance of the Phthalazinone Scaffold in Modern Drug Discovery

The phthalazinone core is a privileged heterocyclic motif of significant interest to the pharmaceutical and medicinal chemistry communities. This nitrogen-containing fused ring system is a common structural feature in a multitude of biologically active compounds.[1] Phthalazinone derivatives have demonstrated a broad spectrum of pharmacological activities, including but not limited to, potent anticancer[2][3], anti-inflammatory, antihypertensive, and antidiabetic properties.[4] Notably, the phthalazinone scaffold is the cornerstone of several approved drugs and clinical candidates, such as the PARP inhibitor Olaparib, used in cancer therapy.[5][6] The versatility and therapeutic potential of this scaffold underscore the critical need for robust and efficient synthetic methodologies for its preparation and derivatization.

This comprehensive guide provides detailed protocols and expert insights into the synthesis of phthalazinones via the cyclocondensation of substituted hydrazines with 2-acyl or 2-formylbenzoic acids. We will explore various methodologies, from classical thermal conditions

to modern microwave-assisted and catalyzed reactions, offering researchers the tools to select and optimize the synthesis of their target phthalazinone derivatives.

Core Synthetic Strategy: Cyclocondensation of Hydrazines with 2-Carbonylbenzoic Acids

The most direct and widely employed method for the synthesis of 4-substituted phthalazin-1(2H)-ones involves the reaction of a 2-acylbenzoic acid or 2-formylbenzoic acid (phthalaldehydic acid) with a hydrazine derivative.^{[7][8][9][10]} The fundamental transformation is a cyclocondensation reaction, where the hydrazine undergoes a nucleophilic attack on the carbonyl groups of the benzoic acid derivative, leading to the formation of the bicyclic phthalazinone ring system after dehydration.

The general reaction scheme can be depicted as follows:

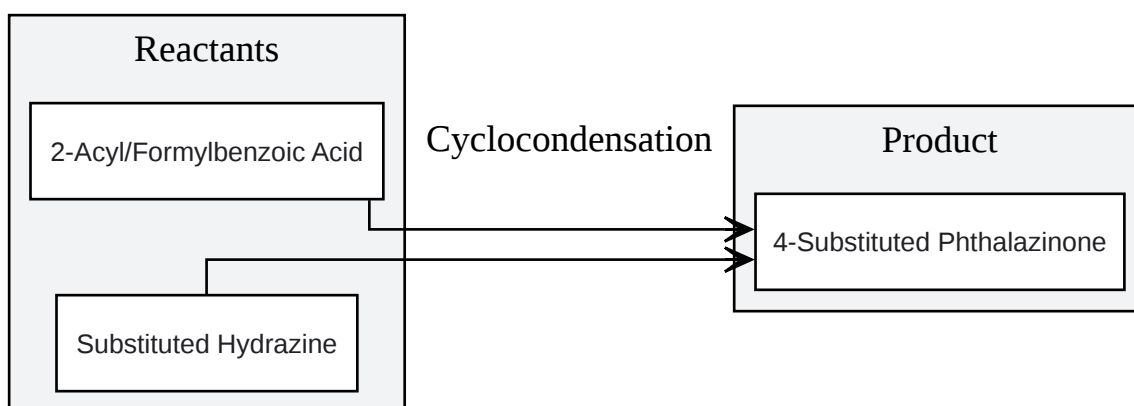

[Click to download full resolution via product page](#)

Figure 1: General workflow for phthalazinone synthesis.

The choice of substituent on the hydrazine (R') and the acyl group on the benzoic acid (R) allows for the generation of a diverse library of phthalazinone derivatives.

Methodologies for Phthalazinone Synthesis

Several methods have been developed to effect this transformation, each with its own set of advantages and considerations. The choice of method often depends on the desired scale,

reaction time, and the nature of the substrates.

Method	Catalyst/Conditions	Typical Reaction Time	Advantages	Disadvantages
Conventional Heating	Reflux in a suitable solvent (e.g., ethanol, butanol, acetic acid)[7][10][11]	4-24 hours	Simple setup, well-established.	Long reaction times, can lead to side products with sensitive substrates.
Microwave-Assisted Synthesis	Microwave irradiation, often with a solid acid catalyst (e.g., Montmorillonite K-10)[12][13]	5-35 minutes	Drastically reduced reaction times, often higher yields and purity.[12]	Requires specialized microwave reactor equipment.
Acid-Catalyzed Synthesis	Oxalic acid in water[4], Ammonium chloride in methanol[14]	1-6 hours	Milder conditions, use of inexpensive and environmentally benign catalysts and solvents.[4][14]	Catalyst may need to be neutralized during workup.

Detailed Experimental Protocols

Protocol 1: Classical Synthesis of 4-Methylphthalazin-1(2H)-one

This protocol describes a well-established method for the synthesis of a simple 4-substituted phthalazinone using conventional heating.[10][11]

Materials:

- 2-Acetylbenzoic acid

- Hydrazine hydrate
- Ethanol
- Round-bottom flask
- Reflux condenser
- Magnetic stirrer and hotplate
- Standard glassware for workup and purification

Procedure:

- **Reaction Setup:** In a round-bottom flask equipped with a reflux condenser and a magnetic stirrer, dissolve 2-acetylbenzoic acid (1 equivalent) in ethanol.
- **Addition of Hydrazine:** To the stirred solution, add hydrazine hydrate (1.2 equivalents) dropwise at room temperature. An exothermic reaction may be observed.
- **Reflux:** Heat the reaction mixture to reflux (approximately 78 °C for ethanol) and maintain for 4-6 hours. The progress of the reaction can be monitored by Thin Layer Chromatography (TLC).
- **Workup:** After the reaction is complete, allow the mixture to cool to room temperature. The product will often precipitate out of the solution.
- **Isolation:** Collect the solid product by vacuum filtration and wash with cold ethanol to remove any unreacted starting materials.
- **Purification:** The crude product can be further purified by recrystallization from a suitable solvent, such as ethanol or an ethanol/water mixture, to yield 4-methylphthalazin-1(2H)-one as a crystalline solid.[9]

Expected Outcome: This procedure typically affords the desired product in good to excellent yields. The purity can be assessed by melting point determination and spectroscopic analysis (¹H NMR, ¹³C NMR, and MS).

Protocol 2: Microwave-Assisted, Solid-Acid-Catalyzed Synthesis of Substituted Phthalazinones

This protocol utilizes microwave irradiation in conjunction with a solid acid catalyst, Montmorillonite K-10, for a rapid and efficient one-pot synthesis.^{[12][13]} This method is particularly advantageous for its short reaction times and high yields.

Materials:

- Phthalaldehydic acid (2-formylbenzoic acid) or a substituted 2-acylbenzoic acid
- Substituted hydrazine (e.g., phenylhydrazine)
- Montmorillonite K-10
- Methanol and Dichloromethane
- Microwave reactor vial
- Microwave reactor (e.g., CEM Discover Benchmate)
- Rotary evaporator

Procedure:

- **Preparation of the Reaction Mixture:** In a round-bottom flask, dissolve the phthalaldehydic acid (1 mmol) in a mixture of methanol (1 mL) and dichloromethane (2 mL). Add the substituted hydrazine (1 equivalent).
- **Addition of Catalyst:** To this solution, add Montmorillonite K-10 in a 5:1 mass ratio relative to the phthalaldehydic acid.
- **Solvent Removal:** Stir the mixture thoroughly and then evaporate the solvent in vacuo to obtain a dry, free-flowing powder.
- **Microwave Irradiation:** Transfer the dry mixture to an open microwave reactor vial. Place the vial in the microwave reactor and irradiate at a constant temperature (e.g., 100 °C) with continuous stirring for 5-35 minutes. The optimal time may vary depending on the substrates.

- **Workup and Isolation:** After irradiation, allow the vial to cool. Add dichloromethane to the solid residue and filter to remove the catalyst. The filtrate contains the product.
- **Purification:** Evaporate the solvent from the filtrate to yield the crude product. Further purification can be achieved by column chromatography on silica gel or recrystallization.

Expert Insight: The use of a solid acid catalyst like Montmorillonite K-10 is key to this protocol's success. The Lewis acid sites on the catalyst activate the carbonyl group of the benzoic acid derivative, facilitating the nucleophilic attack by the hydrazine. Microwave heating accelerates the reaction rate, leading to a significant reduction in reaction time compared to conventional methods.

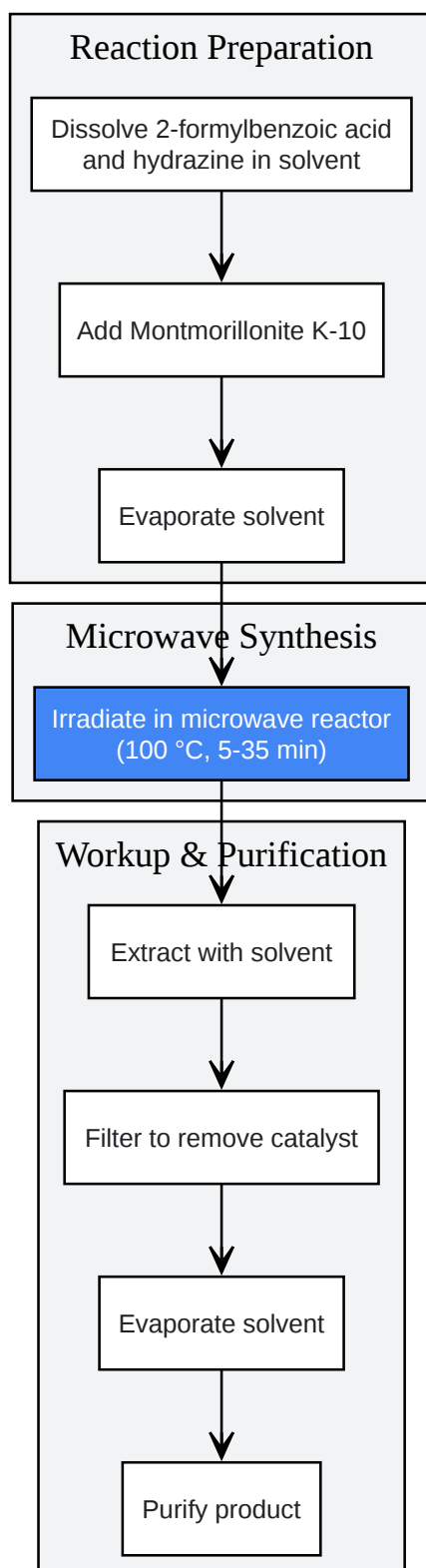

[Click to download full resolution via product page](#)

Figure 2: Workflow for microwave-assisted phthalazinone synthesis.

Protocol 3: Water-Mediated, Oxalic Acid-Catalyzed Synthesis of 2-(Substituted Phenyl)phthalazin-1(2H)-ones

This protocol presents an environmentally friendly approach using water as the solvent and oxalic acid as an inexpensive and readily available catalyst.[4]

Materials:

- Phthalaldehydic acid
- Substituted phenylhydrazine
- Oxalic acid
- Water
- Round-bottom flask with reflux condenser
- Magnetic stirrer and hotplate

Procedure:

- **Reaction Setup:** In a round-bottom flask, prepare a mixture of phthalaldehydic acid (1 mmol), the substituted phenylhydrazine (1 mmol), and a catalytic amount of oxalic acid in water.
- **Reaction:** Heat the mixture to reflux with stirring. The reaction is typically complete within a few hours. Monitor the reaction progress by TLC.
- **Workup and Isolation:** Upon completion, cool the reaction mixture to room temperature. The product often precipitates and can be collected by filtration. Wash the solid with cold water.
- **Purification:** The crude product can be recrystallized from a suitable solvent like ethanol to obtain the pure 2-(substituted phenyl)phthalazin-1(2H)-one.

Causality and Mechanism: The proposed mechanism involves the protonation of the carbonyl oxygen of the phthalaldehydic acid by the oxalic acid catalyst.[4][15] This increases the

electrophilicity of the carbonyl carbon, making it more susceptible to nucleophilic attack by the substituted phenylhydrazine, leading to cyclization and dehydration to form the phthalazinone ring.[4]

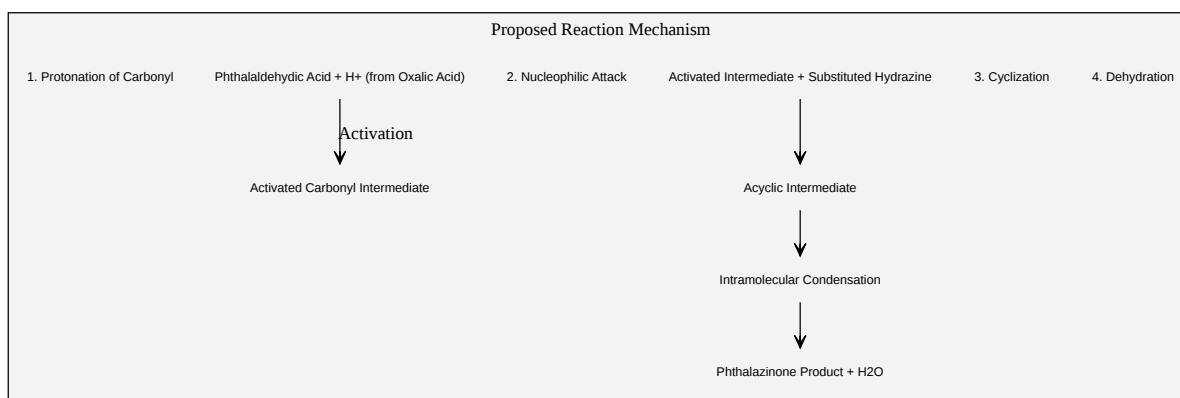

[Click to download full resolution via product page](#)

Figure 3: Proposed mechanism for acid-catalyzed phthalazinone synthesis.

Conclusion and Future Outlook

The synthesis of phthalazinones using substituted hydrazines is a versatile and robust strategy for accessing this important class of heterocyclic compounds. The choice of methodology, from classical heating to modern microwave-assisted and green catalytic approaches, allows for the efficient production of a wide array of derivatives. The protocols outlined in this guide provide a solid foundation for researchers in drug discovery and organic synthesis. As the demand for novel therapeutics continues to grow, the development of even more efficient, selective, and

sustainable methods for the synthesis of phthalazinone-based compounds will remain an active and important area of research.

References

- Menear, K. A., et al. (2008). 4-[3-(4-Cyclopropanecarbonylpiperazine-1-carbonyl)-4-fluorobenzyl]-2H-phthalazin-1-one: A Novel Bioavailable Inhibitor of Poly(ADP-ribose) Polymerase-1. *Journal of Medicinal Chemistry*, 51(20), 6581-6591. Available at: [\[Link\]](#)
- Zhang, L., et al. (2024). Design, synthesis and antitumor activities of phthalazinone derivatives as PARP-1 inhibitors and PARP-1/HDAC-1 inhibitors. *Bioorganic Chemistry*, 152, 107556. Available at: [\[Link\]](#)
- Satyanarayana, G., & Suchand, B. (2018). Palladium-Catalyzed Acylations: A One-pot Diversified Synthesis of Phthalazines, Phthalazinones and Benzoxazinones. *ChemistrySelect*, 3(32), 9204-9208. Available at: [\[Link\]](#)
- Li, M., et al. (2017). Design, Synthesis and Activity Evaluation of New Phthalazinone PARP Inhibitors. *Molecules*, 22(11), 1879. Available at: [\[Link\]](#)
- Varró, D., et al. (2012). Microwave-Promoted Solid-Acid-Catalyzed One-Pot Synthesis of Phthalazinones. *Synlett*, 23(10), 1519-1522. Available at: [\[Link\]](#)
- Various Authors. (n.d.). Phthalazinone. In-depth article. Available at: [\[Link\]](#)
- Mennen, S. M., et al. (2015). Synthesis of 4-Substituted Phthalazin-1(2H)-ones from 2-Acylbenzoic Acids: Controlling Hydrazine in a Pharmaceutical Intermediate through PAT-Guided Process Development. *Organic Process Research & Development*, 19(7), 837-843. Available at: [\[Link\]](#)
- Varró, D., et al. (2012). Microwave-Promoted Solid-Acid-Catalyzed One-Pot Synthesis of Phthalazinones. *Synlett*, 23(10), 1519-1522. Available at: [\[Link\]](#)
- Mennen, S. M., et al. (2015). Synthesis of 4-Substituted Phthalazin-1(2H)-ones from 2-Acylbenzoic Acids: Controlling Hydrazine in a Pharmaceutical Intermediate through PAT-Guided Process Development. *Organic Process Research & Development*, 19(7), 837-843. Available at: [\[Link\]](#)

- Al-Suwaidan, I. A., et al. (2022). Microwave-Assisted Synthesis of Phthalazinone Derivatives with Biological Activity and In Silico Antiproliferative Studies. *Molecules*, 27(3), 896. Available at: [\[Link\]](#)
- Ghorbani-Vaghei, R., & Malaekhepour, S. M. (2018). Water-mediated oxalic acid catalysed one-pot synthesis of 2-(substituted phenyl) phthalazin-1(2H)-ones. *Journal of Chemical Sciences*, 130(4), 54. Available at: [\[Link\]](#)
- Reddy, T. R., & Satyanarayana, G. (2020). Transition-metal-catalyzed C–H bond activation/functionalization and annulation of phthalazinones. *Organic & Biomolecular Chemistry*, 18(30), 5779-5802. Available at: [\[Link\]](#)
- El-Sayed, N. N. E., et al. (2018). Development of novel synthesized phthalazinone-based PARP-1 inhibitors with apoptosis inducing mechanism in lung cancer. *Bioorganic Chemistry*, 77, 359-369. Available at: [\[Link\]](#)
- Vila, N., et al. (2015). Phthalazin-1(2H)-one as a remarkable scaffold in drug discovery. *European Journal of Medicinal Chemistry*, 90, 48-64. Available at: [\[Link\]](#)
- Vila, N., et al. (2015). Phthalazin-1(2H)-one as a remarkable scaffold in drug discovery. *European Journal of Medicinal Chemistry*, 90, 48-64. Available at: [\[Link\]](#)
- Patil, A. M., et al. (2023). Ammonium chloride mediated synthesis of 2-aryl-phthalazinone from O-formyl benzoic acid and in silico applications. *ARKIVOC*, 2023(vii), 1-11. Available at: [\[Link\]](#)
- Ghorbani-Vaghei, R., & Malaekhepour, S. M. (2018). Proposed mechanism for the synthesis of phthalazinones. *ResearchGate*. Available at: [\[Link\]](#)
- Vila, N., et al. (2018). Novel Phthalazin-1(2H)-One Derivatives Displaying a Dithiocarbamate Moiety as Potential Anticancer Agents. *Molecules*, 23(11), 2949. Available at: [\[Link\]](#)

Need Custom Synthesis?

BenchChem offers custom synthesis for rare earth carbides and specific isotopic labeling.

Email: info@benchchem.com or [Request Quote Online](#).

Sources

- [1. researchgate.net \[researchgate.net\]](#)
- [2. Design, synthesis and antitumor activities of phthalazinone derivatives as PARP-1 inhibitors and PARP-1/HDAC-1 inhibitors - PubMed \[pubmed.ncbi.nlm.nih.gov\]](#)
- [3. Development of novel synthesized phthalazinone-based PARP-1 inhibitors with apoptosis inducing mechanism in lung cancer - PubMed \[pubmed.ncbi.nlm.nih.gov\]](#)
- [4. tandfonline.com \[tandfonline.com\]](#)
- [5. researchgate.net \[researchgate.net\]](#)
- [6. Design, Synthesis and Activity Evaluation of New Phthalazinone PARP Inhibitors - PubMed \[pubmed.ncbi.nlm.nih.gov\]](#)
- [7. bu.edu.eg \[bu.edu.eg\]](#)
- [8. researchgate.net \[researchgate.net\]](#)
- [9. pubs.acs.org \[pubs.acs.org\]](#)
- [10. pdf.benchchem.com \[pdf.benchchem.com\]](#)
- [11. Novel Phthalazin-1\(2H\)-One Derivatives Displaying a Dithiocarbamate Moiety as Potential Anticancer Agents - PMC \[pmc.ncbi.nlm.nih.gov\]](#)
- [12. Thieme E-Books & E-Journals - \[thieme-connect.com\]](#)
- [13. researchgate.net \[researchgate.net\]](#)
- [14. arkat-usa.org \[arkat-usa.org\]](#)
- [15. researchgate.net \[researchgate.net\]](#)
- [To cite this document: BenchChem. \[Application Note & Protocols for the Synthesis of Phthalazinones Using Substituted Hydrazines\]. BenchChem, \[2026\]. \[Online PDF\]. Available at: \[https://www.benchchem.com/product/b12451147/docs#application-note-protocols-for-the-synthesis-of-phthalazinones-using-substituted-hydrazines\]](#)

Disclaimer & Data Validity:

The information provided in this document is for Research Use Only (RUO) and is strictly not intended for diagnostic or therapeutic procedures. While BenchChem strives to provide accurate protocols, we make no warranties, express or implied, regarding the fitness of this product for every specific experimental setup.

Technical Support: The protocols provided are for reference purposes. Unsure if this reagent suits your experiment?

Need Industrial/Bulk Grade? [Request Custom Synthesis Quote](#)

BenchChem

Our mission is to be the trusted global source of essential and advanced chemicals, empowering scientists and researchers to drive progress in science and industry.

Contact

Address: 3281 E Guasti Rd
Ontario, CA 91761, United States
Phone: (601) 213-4426
Email: info@benchchem.com

[Contact our Ph.D. Support Team for a compatibility check](#)