

Technical Comparison Guide: Mass Spectrometry Profiling of 3-Methoxy-2,6-dimethylbenzoic Acid

Author: BenchChem Technical Support Team. **Date:** April 2026

Compound of Interest

Compound Name: 3-Methoxy-2,6-dimethylbenzoic acid

Cat. No.: B12448855

[Get Quote](#)

Executive Summary

Objective: To provide a definitive structural elucidation guide for **3-Methoxy-2,6-dimethylbenzoic acid**, distinguishing it from isobaric impurities and structural isomers (e.g., 2,4-dimethyl analogs) using Mass Spectrometry (MS).

Core Insight: The unique 2,6-dimethyl substitution pattern creates a "Double Ortho Effect," forcing the carboxyl group perpendicular to the aromatic ring. This steric inhibition of resonance triggers a specific fragmentation channel—the elimination of H₂O (18 Da)—which is mechanistically distinct from the standard loss of hydroxyl radicals (17 Da) observed in non-ortho-substituted isomers. This guide compares these fragmentation pathways to provide a self-validating identification protocol.

Structural Context: The "Double Ortho" Mechanism

In mass spectrometry, identifying regioisomers of polysubstituted benzoic acids relies on the Ortho Effect.

- Standard Benzoic Acids: Typically fragment via

-cleavage, losing a hydroxyl radical (OH, 17 Da) to form an acylium ion

.
- **3-Methoxy-2,6-dimethylbenzoic Acid** (The Target): The two methyl groups at positions 2 and 6 create severe steric crowding. This forces the carboxylic acid moiety out of the aromatic plane, preventing conjugation.
 - Consequence: The carbonyl oxygen is positioned optimally to abstract a hydrogen from an ortho-methyl group.[1]
 - Result: A dominant loss of water (H₂O, 18 Da) to form a stable bicyclic or ketene-like cation, rather than the simple loss of

OH.

Comparative Fragmentation Analysis

This section compares the fragmentation of the target compound against its most likely structural isomer, 3-Methoxy-2,4-dimethylbenzoic acid. While both have the same molecular weight (180.20 g/mol), their fragmentation fingerprints differ significantly due to the steric environment.

Data Summary: Target vs. Alternative Isomer

Feature	Target: 3-Methoxy-2,6-dimethylbenzoic acid	Alternative: 3-Methoxy-2,4-dimethylbenzoic acid	Mechanistic Cause
Molecular Ion ()	m/z 180 (Strong)	m/z 180 (Strong)	Stable aromatic ring. [1]
Primary Loss	(m/z 162)	(m/z 163)	Ortho Effect: 2,6-isomer favors H-transfer from methyl to OH; 2,4-isomer favors simple cleavage.
Secondary Loss			Loss of methyl radical from the methoxy ether group.
Decarboxylation	(m/z 136)	(m/z 136)	Loss of neutral CO ₂ (common in ESI-mode).
Base Peak (EI)	Often m/z 162 or 134	Often m/z 163 or 135	2,6-isomer forms stable isobenzofuran-like cation after water loss.[1]

Mechanistic Pathway Diagram

The following diagram illustrates the divergent pathways. The Red Path highlights the diagnostic "Ortho Effect" unique to the 2,6-substitution.

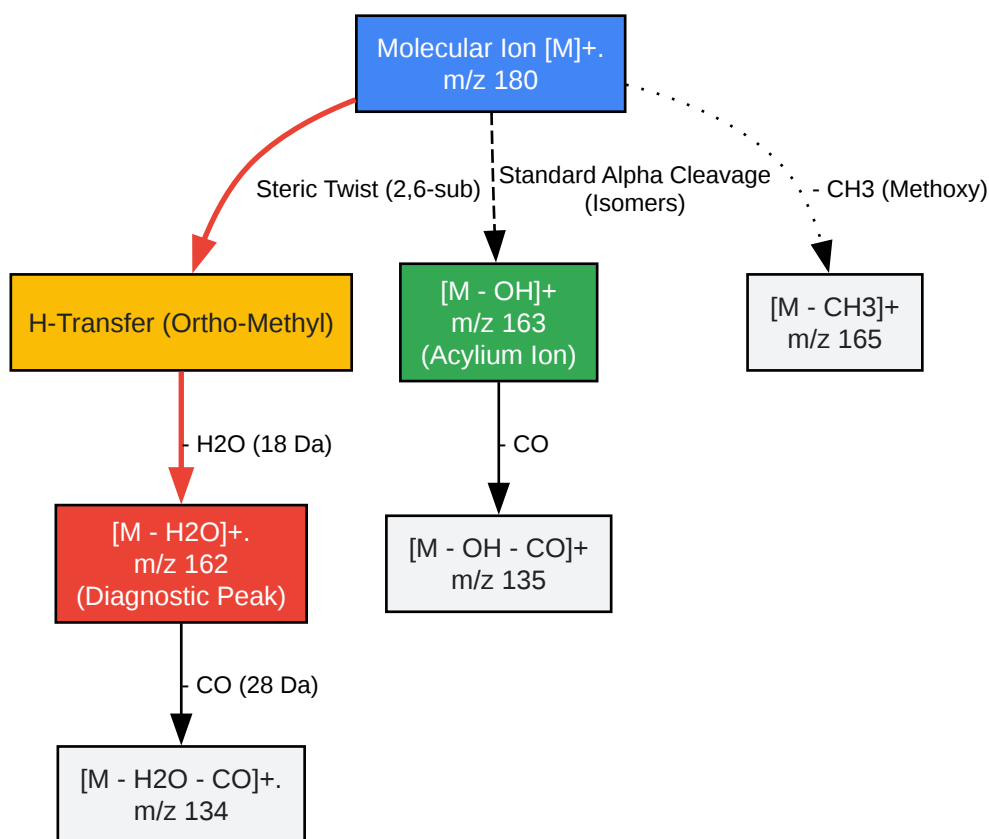

[Click to download full resolution via product page](#)

Figure 1: Fragmentation logic showing the diagnostic "Ortho Effect" pathway (Red) specific to 2,6-dimethyl substitution, contrasting with standard acylium formation (Green).

Experimental Protocols

To reliably generate these spectra, two distinct methods are recommended depending on the available instrumentation.

Method A: GC-MS (Derivatization Required)

Best for: High-resolution structural confirmation and impurity profiling. Note: Direct injection of free carboxylic acids leads to peak tailing.[1] Derivatization is mandatory.[1]

- Sample Preparation:
 - Dissolve 1 mg of **3-Methoxy-2,6-dimethylbenzoic acid** in 100 μ L Ethyl Acetate.

- Derivatization: Add 50 μ L BSTFA + 1% TMCS (Silylation reagent).
- Incubate at 60°C for 30 minutes. (Target forms the TMS-ester, MW = 252).
- GC Parameters:
 - Column: DB-5ms (30m x 0.25mm, 0.25 μ m).[1]
 - Inlet: 250°C, Split 10:1.
 - Oven: 80°C (1 min) \rightarrow 20°C/min \rightarrow 280°C (5 min).
- MS Parameters (EI):
 - Source: 230°C, Energy: 70 eV.[1]
 - Scan Range: m/z 50–300.[1]
- Expected Shift: The TMS-ester (m/z 252) will lose Methyl (15 Da) to form m/z 237 ().[1] The "Ortho Effect" in TMS esters typically manifests as the loss of TMS-OH (90 Da) or complex rearrangements, distinguishing it from isomers.

Method B: Direct Infusion ESI-MS/MS (LC-MS)

Best for: Rapid identification without derivatization.

- Sample Preparation:
 - Dissolve to 10 μ g/mL in 50:50 Methanol:Water + 0.1% Formic Acid.[1]
- Ionization: Electrospray Ionization (ESI) in Negative Mode ().
 - Precursor Ion: m/z 179.[1]
- MS/MS Fragmentation (CID):
 - Apply Collision Energy (CE): 15–30 eV.[1]

- Key Transition: m/z 179

m/z 135 (Loss of

, Decarboxylation).[1]
- Differentiation: 2,6-substituted benzoates decarboxylate more readily than isomers due to the relief of steric strain upon losing the bulky carboxyl group.

References

- NIST Mass Spectrometry Data Center. (2023).[1] Mass Spectrum of 2,6-Dimethylbenzoic Acid. National Institute of Standards and Technology.[1][2][3] [\[Link\]](#)
- Smith, R. M. (2004).[1] Understanding Mass Spectra: A Basic Approach. Wiley-Interscience. [1] (Detailed discussion on the "Ortho Effect" in mass spectrometry).
- Waters Corporation. (2021).[1] Direct Separations of the Six Positional Isomers of Disubstituted Benzoic Acids. Application Note. [\[Link\]](#)

Need Custom Synthesis?

BenchChem offers custom synthesis for rare earth carbides and specific isotopic labeling.

Email: info@benchchem.com or [Request Quote Online](#).

Sources

- 1. 2,6-Dimethylbenzoic acid | C₉H₁₀O₂ | CID 12439 - PubChem [\[pubchem.ncbi.nlm.nih.gov\]](https://pubchem.ncbi.nlm.nih.gov)
- 2. Benzoic acid, 2,6-dimethyl- [\[webbook.nist.gov\]](https://webbook.nist.gov)
- 3. Benzoic acid, 2,6-dimethyl- [\[webbook.nist.gov\]](https://webbook.nist.gov)
- To cite this document: BenchChem. [Technical Comparison Guide: Mass Spectrometry Profiling of 3-Methoxy-2,6-dimethylbenzoic Acid]. BenchChem, [2026]. [Online PDF]. Available at: [\[https://www.benchchem.com/product/b12448855/docs#technical-comparison-guide-mass-spectrometry-profiling-of-3-methoxy-2-6-dimethylbenzoic-acid\]](https://www.benchchem.com/product/b12448855/docs#technical-comparison-guide-mass-spectrometry-profiling-of-3-methoxy-2-6-dimethylbenzoic-acid)

Disclaimer & Data Validity:

The information provided in this document is for Research Use Only (RUO) and is strictly not intended for diagnostic or therapeutic procedures. While BenchChem strives to provide accurate protocols, we make no warranties, express or implied, regarding the fitness of this product for every specific experimental setup.

Technical Support: The protocols provided are for reference purposes. Unsure if this reagent suits your experiment?

Need Industrial/Bulk Grade? [Request Custom Synthesis Quote](#)

BenchChem

Our mission is to be the trusted global source of essential and advanced chemicals, empowering scientists and researchers to drive progress in science and industry.

Contact

Address: 3281 E Guasti Rd
Ontario, CA 91761, United States
Phone: (601) 213-4426
Email: info@benchchem.com

[Contact our Ph.D. Support Team for a compatibility check](#)