

# Comparative Guide: Mass Spectrometry Fragmentation Dynamics of Halogenated Thienopyridines

**Author:** BenchChem Technical Support Team. **Date:** May 2026

## Compound of Interest

Compound Name: *2-Bromo-6-chlorothieno[3,2-c]pyridine*

Cat. No.: *B12440903*

[Get Quote](#)

## Executive Summary

Thienopyridines (e.g., thieno[2,3-b]pyridine) represent a privileged scaffold in medicinal chemistry, serving as the core for anti-platelet agents, kinase inhibitors, and anti-proliferative drugs. The introduction of halogens (Cl, Br, I) into this heteroaromatic system is a critical strategy for modulating metabolic stability and potency.

However, characterizing these analogs requires a nuanced understanding of their mass spectrometric behavior. This guide objectively compares the fragmentation dynamics of halogenated thienopyridines under Electron Ionization (EI) and Electrospray Ionization (ESI), providing a self-validating framework for structural elucidation.

## The Halogen Signature: Isotopic & Homolytic Logic

Before analyzing the scaffold, one must validate the halogen substituent. Unlike standard organic fragments, halogens provide a "fingerprint" prior to fragmentation due to unique isotopic distributions and carbon-halogen (C-X) bond energies.

## Comparative Analysis of Halogen Substituents

| Feature                     | Chlorine (Cl)   | Bromine (Br)                          | Iodine (I)                                    | Impact on Thienopyridine MS                            |
|-----------------------------|---|---------------------------------------|---|--|
| Natural Isotopes            | Cl (75.8%)<br>Cl (24.2%)  | Br (50.7%)<br>Br (49.3%)              | I (100%)                                      | Diagnostic M+2 peak intensity.                         |
| Isotopic Pattern            | 3:1 (M : M+2)   | 1:1 (M : M+2)                         | Single Peak                                   | Cl and Br are easily identified by "doublet" patterns. |
| C-X Bond Energy             | ~397 kJ/mol   | ~280 kJ/mol                           | ~209 kJ/mol                                   | Determines likelihood of radical loss.                 |
| Fragmentation Tendency (EI) | Low. Often retained on the ring until late-stage fragmentation. | Medium. Competing loss of Br vs. HCN. | High. Rapid loss of I is often the base peak. |  |

“

*Expert Insight: In EI-MS, if you observe a molecular ion (*

*) with a 1:1 isotopic ratio that immediately loses 79/81 Da to form a base peak, the halogen is Bromine, and the C-Br bond is likely at a reactive position (e.g., C-2 or C-3 of the thiophene ring).*

## Ionization Modalities: EI vs. ESI/CID[1][2]

The choice of ionization dictates the fragmentation mechanism. EI is "hard" (radical-driven), while ESI is "soft" (collision-driven).

## Performance Comparison Table

| Parameter               | Electron Ionization (EI)                                  | Electrospray Ionization (ESI-MS/MS)   |
|-------------------------|---|---|
| Ion Type                | Odd-electron Radical Cation ( )                           | Even-electron Protonated Ion ( )  |
| Primary Mechanism       | Homolytic cleavage, Radical site migration.               | Heterolytic cleavage, Charge-remote fragmentation (CID).                    |
| Thienopyridine Behavior | Extensive ring shattering. Sequential loss of HCN and CS. | Stable molecular ion. Fragmentation requires collision energy (CE).         |
| Halogen Fate            | Radical loss ( ) is common, especially for I and Br.      | Halogen often retained; loss of HX (acid) is more common than radical loss. |
| Application             | GC-MS (Volatile intermediates).                           | LC-MS (Polar drugs, metabolites).   |

## Mechanistic Fragmentation Pathways[3][4]

The fragmentation of thienopyridines follows a logic dictated by the stability of the aromatic rings. The diagram below illustrates the consensus pathway for a generic Halogenated Thieno[2,3-b]pyridine.

### Core Pathways:

- Pathway A (Halogen Loss): Driven by weak C-X bonds (dominant for Iodine/Bromine).
- Pathway B (Pyridine Collapse): Loss of HCN (27 Da), characteristic of nitrogen heterocycles.
- Pathway C (Thiophene Collapse): Loss of CS (44 Da) or CHS (45 Da), breaking the sulfur ring.

## Visualization: Fragmentation Decision Tree

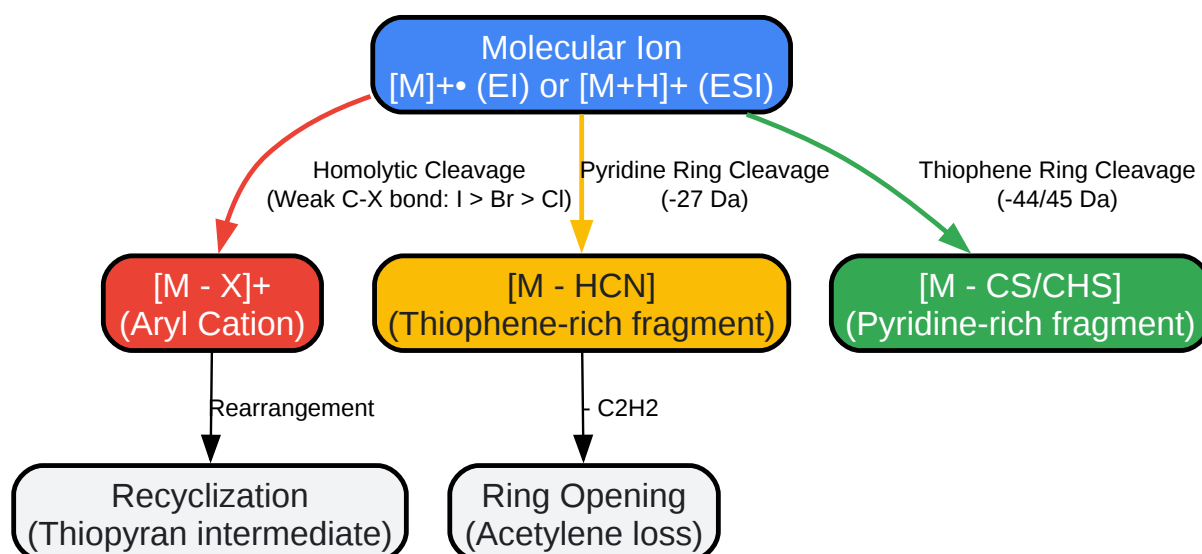

[Click to download full resolution via product page](#)

Figure 1: Consensus fragmentation tree for halogenated thienopyridines. Pathway dominance depends on halogen bond strength (Red path dominates for Iodine).

## Experimental Protocol (Self-Validating)

To ensure reproducible data, follow this specific workflow. This protocol includes "Checkpoints" to validate system performance.

### A. Sample Preparation[2][5]

- Solvent: Dissolve 1 mg of compound in 1 mL of HPLC-grade Methanol (MeOH).
- Dilution: Dilute to 10 µg/mL with 0.1% Formic Acid in Water/MeOH (50:50) for ESI.
- Checkpoint: Verify solution clarity. Turbidity indicates precipitation, which will suppress ionization.

### B. LC-MS/MS Workflow (ESI)

Targeting [M+H]<sup>+</sup> species.

- Source Parameters:

- Capillary Voltage: 3.5 kV
- Desolvation Temp: 350°C
- Cone Voltage: 30 V (Adjust to maximize precursor).
- MS2 Acquisition (Product Ion Scan):
  - Select precursor mass (e.g., m/z 213/215 for Bromo-thienopyridine).
  - Collision Energy Ramp: 10 eV to 50 eV.
- Data Validation:
  - Look for the "Survivability" of the halogen. In ESI, the halogen often remains attached during the first HCN loss.
  - Validation: If the M+2 peak disappears in the MS2 spectrum, you have lost the halogen (likely Br or Cl).

## C. GC-MS Workflow (EI)

Targeting M+• radical cations.

- Inlet: Splitless mode, 250°C.
- Column: Rxi-5Sil MS (or equivalent), 30m x 0.25mm.
- Ion Source: 70 eV (Standard).
- Data Validation:
  - Check the Molecular Ion ( ) intensity.[\[1\]](#)[\[2\]](#)[\[3\]](#)
  - Validation: If is absent but a base peak exists at [M-Halogen], reduce source temperature to 200°C to confirm thermal stability.

## Workflow Visualization

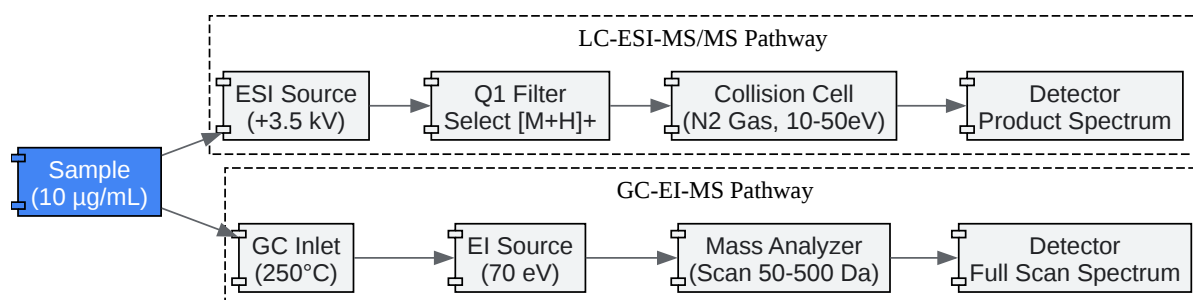

[Click to download full resolution via product page](#)

Figure 2: Parallel experimental workflow for comprehensive structural characterization.

## References

- Structure-Activity Relationships of Thienopyridines
  - Source: National Institutes of Health (NIH) / PMC.
  - Context: Discusses synthesis and characterization of thieno[2,3-b]pyridines, including MS data for purity verific
  - Link:
- General Fragmentation of Heterocycles (The "HCN Loss" Rule)
  - Source: ChemGuide / SDBS D
  - Context: Foundational principles of nitrogen heterocycle fragment
  - Link:
- EI vs.
  - Source: Fiveable / Analytical Chemistry Notes.

- Context: Comparison of Hard (EI) vs Soft (ESI) ionization techniques and their impact on fragmentation.[4][5]
- Link:
- Thienopyridine Chemical Properties & Spectra
  - Source: PubChem (NIH).
  - Context: Specific data entries for Thieno[2,3-b]pyridine derivatives, including molecular weight and computed properties useful for MS prediction.
  - Link:

### Need Custom Synthesis?

BenchChem offers custom synthesis for rare earth carbides and specific isotopic labeling.

Email: [info@benchchem.com](mailto:info@benchchem.com) or [Request Quote Online](#).

## Sources

- [1. Ionization Modes // Mass Spectrometry & Proteomics Facility // University of Notre Dame \[massspec.nd.edu\]](#)
- [2. article.sapub.org \[article.sapub.org\]](#)
- [3. chemguide.co.uk \[chemguide.co.uk\]](#)
- [4. chemistry.stackexchange.com \[chemistry.stackexchange.com\]](#)
- [5. fiveable.me \[fiveable.me\]](#)
- To cite this document: BenchChem. [Comparative Guide: Mass Spectrometry Fragmentation Dynamics of Halogenated Thienopyridines]. BenchChem, [2026]. [Online PDF]. Available at: [\[https://www.benchchem.com/product/b12440903/docs#comparative-guide-mass-spectrometry-fragmentation-dynamics-of-halogenated-thienopyridines\]](https://www.benchchem.com/product/b12440903/docs#comparative-guide-mass-spectrometry-fragmentation-dynamics-of-halogenated-thienopyridines)

---

### Disclaimer & Data Validity:

The information provided in this document is for Research Use Only (RUO) and is strictly not intended for diagnostic or therapeutic procedures. While BenchChem strives to provide

accurate protocols, we make no warranties, express or implied, regarding the fitness of this product for every specific experimental setup.

**Technical Support:** The protocols provided are for reference purposes. Unsure if this reagent suits your experiment?

**Need Industrial/Bulk Grade?** [Request Custom Synthesis Quote](#)

## BenchChem

Our mission is to be the trusted global source of essential and advanced chemicals, empowering scientists and researchers to drive progress in science and industry.

### Contact

Address: 3281 E Guasti Rd

Ontario, CA 91761, United States

Phone: (601) 213-4426

Email: [info@benchchem.com](mailto:info@benchchem.com)

[Contact our Ph.D. Support Team for a compatibility check](#)