

Application Notes and Protocols for 264W94 in Cell Culture Assays

Author: BenchChem Technical Support Team. **Date:** April 2026

Compound of Interest

Compound Name:	264W94
CAS No.:	178259-25-1
Cat. No.:	B1244617

[Get Quote](#)

For Researchers, Scientists, and Drug Development Professionals

Introduction

264W94 is a potent and selective inhibitor of the Ileal Bile Acid Transporter (IBAT), also known as the Apical Sodium-dependent Bile Acid Transporter (ASBT or SLC10A2).[1][2] This transporter is primarily responsible for the reabsorption of bile acids from the terminal ileum into the enterohepatic circulation.[2][3] By competitively inhibiting IBAT, **264W94** effectively blocks this reabsorption, leading to increased fecal excretion of bile acids.[1] This interruption of the enterohepatic circulation of bile acids has significant downstream effects, making **264W94** a valuable tool for research in metabolic diseases.

The primary consequences of IBAT inhibition by **264W94** are twofold. First, the liver compensates for the loss of returning bile acids by upregulating the synthesis of new bile acids from cholesterol. The rate-limiting enzyme in this process is Cholesterol 7 α -hydroxylase (CYP7A1), whose expression is induced. This increased consumption of cholesterol can lead to a reduction in circulating LDL and VLDL cholesterol levels. Second, the increased

concentration of bile acids in the distal intestine and colon leads to the activation of the G protein-coupled bile acid receptor TGR5, which stimulates the release of glucagon-like peptide-1 (GLP-1). This has beneficial effects on glucose homeostasis, including enhanced insulin secretion and improved glycemic control.

These application notes provide detailed protocols for utilizing **264W94** in cell culture assays to investigate its mechanism of action and downstream effects. The protocols focus on two key cell-based assays: a bile acid uptake assay using the human intestinal cell line Caco-2 and a CYP7A1 expression assay using the human liver cell line HepG2.

Data Presentation

Table 1: In Vitro Inhibitory Activity of **264W94**

Parameter	Species/System	Substrate	Value	Reference
IC ₅₀	Rat brush border membrane vesicles	10 μM [³ H]Taurocholic Acid	0.24 μM	
IC ₅₀	Monkey brush border membrane vesicles	10 μM [³ H]Taurocholic Acid	0.41 μM	
K _i	CHO cells expressing human IBAT	Taurocholic Acid	0.2 μM	

Table 2: In Vivo Efficacy of **264W94**

Parameter	Animal Model	Effect	Dosage	Reference
ED ₃₀	Rats and Mice	Decreased absorption of (75)SeHCAT	0.02 mg/kg bid	
Cholesterol Reduction	Diet-induced hypercholesterolemic rats	Up to 61% reduction in serum LDL+VLDL cholesterol	0.03-1.0 mg/kg bid	
GLP-1 Increase	Zucker Diabetic Fatty (ZDF) rats	~2-fold increase in plasma GLP-1	Not specified	
Insulin Increase	Zucker Diabetic Fatty (ZDF) rats	~3-fold increase in plasma insulin	Not specified	

Experimental Protocols

Protocol 1: Inhibition of Bile Acid Uptake in Caco-2 Cells

This assay measures the ability of **264W94** to inhibit the uptake of a labeled bile acid substrate, such as [³H]taurocholic acid, into a confluent monolayer of Caco-2 cells, which endogenously express IBAT/ASBT.

Materials:

- Caco-2 cells (ATCC® HTB-37™)
- Dulbecco's Modified Eagle's Medium (DMEM) with high glucose
- Fetal Bovine Serum (FBS)
- Non-Essential Amino Acids (NEAA)
- Penicillin-Streptomycin
- Transwell® permeable supports (e.g., 12-well, 0.4 µm pore size)

- **264W94**
- [³H]Taurocholic Acid (or other suitable labeled bile acid)
- Hanks' Balanced Salt Solution (HBSS) with Ca²⁺ and Mg²⁺
- Scintillation cocktail
- Scintillation counter
- Cell lysis buffer (e.g., 0.1% SDS in 0.1 N NaOH)
- Protein assay kit (e.g., BCA)

Methodology:

- Cell Culture and Seeding:
 - Culture Caco-2 cells in DMEM supplemented with 10% FBS, 1% NEAA, and 1% Penicillin-Streptomycin at 37°C in a 5% CO₂ incubator.
 - Seed Caco-2 cells onto Transwell® inserts at a density of approximately 6 x 10⁴ cells/cm².
 - Culture the cells for 18-21 days to allow for differentiation and formation of a confluent monolayer with tight junctions. Change the medium every 2-3 days.
 - Monitor the integrity of the monolayer by measuring the transepithelial electrical resistance (TEER).
- Preparation of Reagents:
 - Prepare a stock solution of **264W94** in a suitable solvent (e.g., DMSO).
 - Prepare a working solution of [³H]taurocholic acid in HBSS.
 - Prepare various concentrations of **264W94** in HBSS. Ensure the final DMSO concentration is consistent across all wells and does not exceed 0.5%.
- Bile Acid Uptake Assay:

- Wash the Caco-2 monolayers twice with pre-warmed HBSS.
- Pre-incubate the cells with HBSS containing different concentrations of **264W94** (or vehicle control) in the apical chamber for 15-30 minutes at 37°C.
- Initiate the uptake by adding HBSS containing [³H]taurocholic acid and the corresponding concentration of **264W94** (or vehicle) to the apical chamber.
- Incubate for a predetermined time (e.g., 10-30 minutes) at 37°C.
- Terminate the uptake by aspirating the radioactive solution and washing the monolayers three times with ice-cold HBSS.
- Quantification:
 - Lyse the cells in the Transwell® insert with cell lysis buffer.
 - Transfer the cell lysate to a scintillation vial, add scintillation cocktail, and measure the radioactivity using a scintillation counter.
 - Use a portion of the cell lysate to determine the total protein concentration using a protein assay kit.
 - Normalize the radioactivity (counts per minute, CPM) to the protein concentration (mg) for each well.
- Data Analysis:
 - Calculate the percentage of inhibition for each concentration of **264W94** compared to the vehicle control.
 - Plot the percentage of inhibition against the log concentration of **264W94** and determine the IC₅₀ value using non-linear regression analysis.

Protocol 2: Measurement of CYP7A1 Expression in HepG2 Cells

This protocol details the investigation of the downstream effects of reduced bile acid signaling by measuring the expression of the CYP7A1 gene in HepG2 cells. As this is an indirect effect in vivo, this assay can be adapted for co-culture systems or by using conditioned media from **264W94**-treated intestinal cells. A direct treatment protocol is provided for initial screening.

Materials:

- HepG2 cells (ATCC® HB-8065™)
- Eagle's Minimum Essential Medium (EMEM)
- Fetal Bovine Serum (FBS)
- Penicillin-Streptomycin
- **264W94**
- Bile acids (e.g., chenodeoxycholic acid, CDCA) as a control for repression
- RNA extraction kit
- cDNA synthesis kit
- qPCR master mix
- Primers for CYP7A1 and a housekeeping gene (e.g., GAPDH, ACTB)
- Real-time PCR system
- Protein lysis buffer (e.g., RIPA buffer) with protease inhibitors
- Primary antibody against CYP7A1
- Secondary antibody (HRP-conjugated)
- Chemiluminescence substrate
- Western blotting equipment

Methodology:

Part A: Gene Expression Analysis (qRT-PCR)

- Cell Culture and Treatment:
 - Culture HepG2 cells in EMEM supplemented with 10% FBS and 1% Penicillin-Streptomycin at 37°C in a 5% CO₂ incubator.
 - Seed HepG2 cells in 6-well plates and allow them to reach 70-80% confluency.
 - Treat the cells with various concentrations of **264W94** for 24-48 hours. Include a positive control for repression (e.g., CDCA) and a vehicle control. Note: The direct effect of **264W94** on HepG2 cells is exploratory; in vivo, the effect is due to reduced bile acid return.
- RNA Extraction and cDNA Synthesis:
 - Extract total RNA from the treated cells using an RNA extraction kit according to the manufacturer's instructions.
 - Synthesize cDNA from the extracted RNA using a cDNA synthesis kit.
- Quantitative Real-Time PCR (qPCR):
 - Perform qPCR using the synthesized cDNA, qPCR master mix, and primers for CYP7A1 and the housekeeping gene.
 - Analyze the qPCR data using the $\Delta\Delta C_t$ method to determine the relative fold change in CYP7A1 expression compared to the vehicle control.

Part B: Protein Expression Analysis (Western Blot)

- Protein Extraction:
 - Lyse the treated HepG2 cells with protein lysis buffer.
 - Determine the protein concentration of the lysates.

- Western Blotting:
 - Separate equal amounts of protein by SDS-PAGE and transfer to a PVDF membrane.
 - Block the membrane and incubate with the primary antibody against CYP7A1 overnight at 4°C.
 - Wash the membrane and incubate with the HRP-conjugated secondary antibody.
 - Detect the protein bands using a chemiluminescence substrate and an imaging system.
 - Quantify the band intensity and normalize to a loading control (e.g., GAPDH or β -actin).

Visualization of Pathways and Workflows

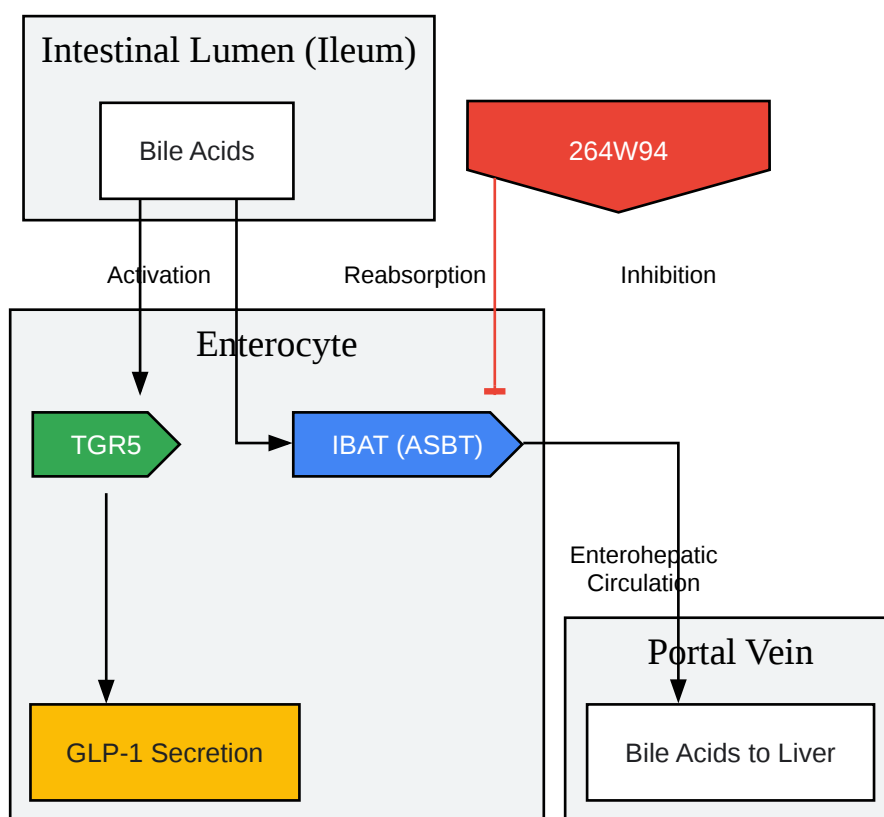

[Click to download full resolution via product page](#)

Caption: Mechanism of **264W94** action in the intestine.

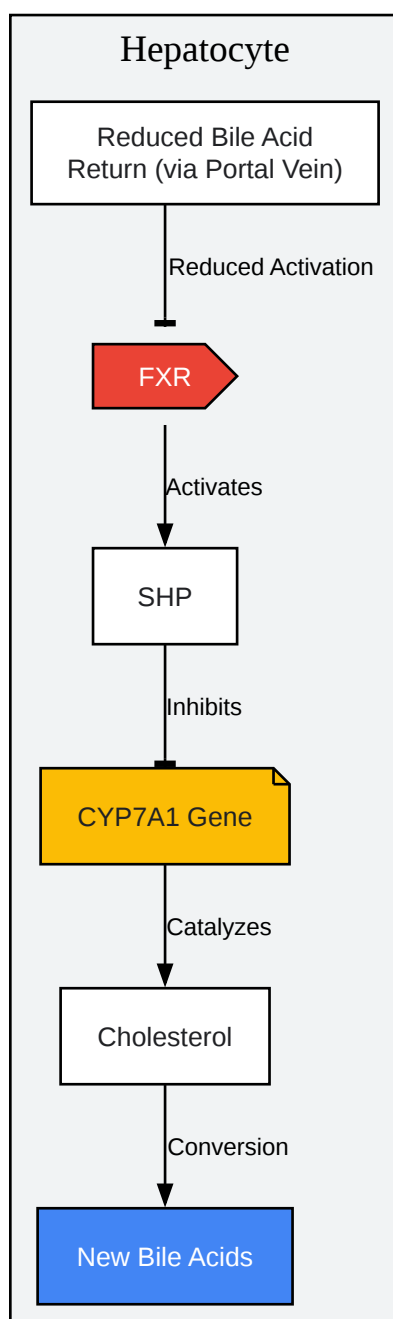

[Click to download full resolution via product page](#)

Caption: Downstream effects of IBAT inhibition in the liver.

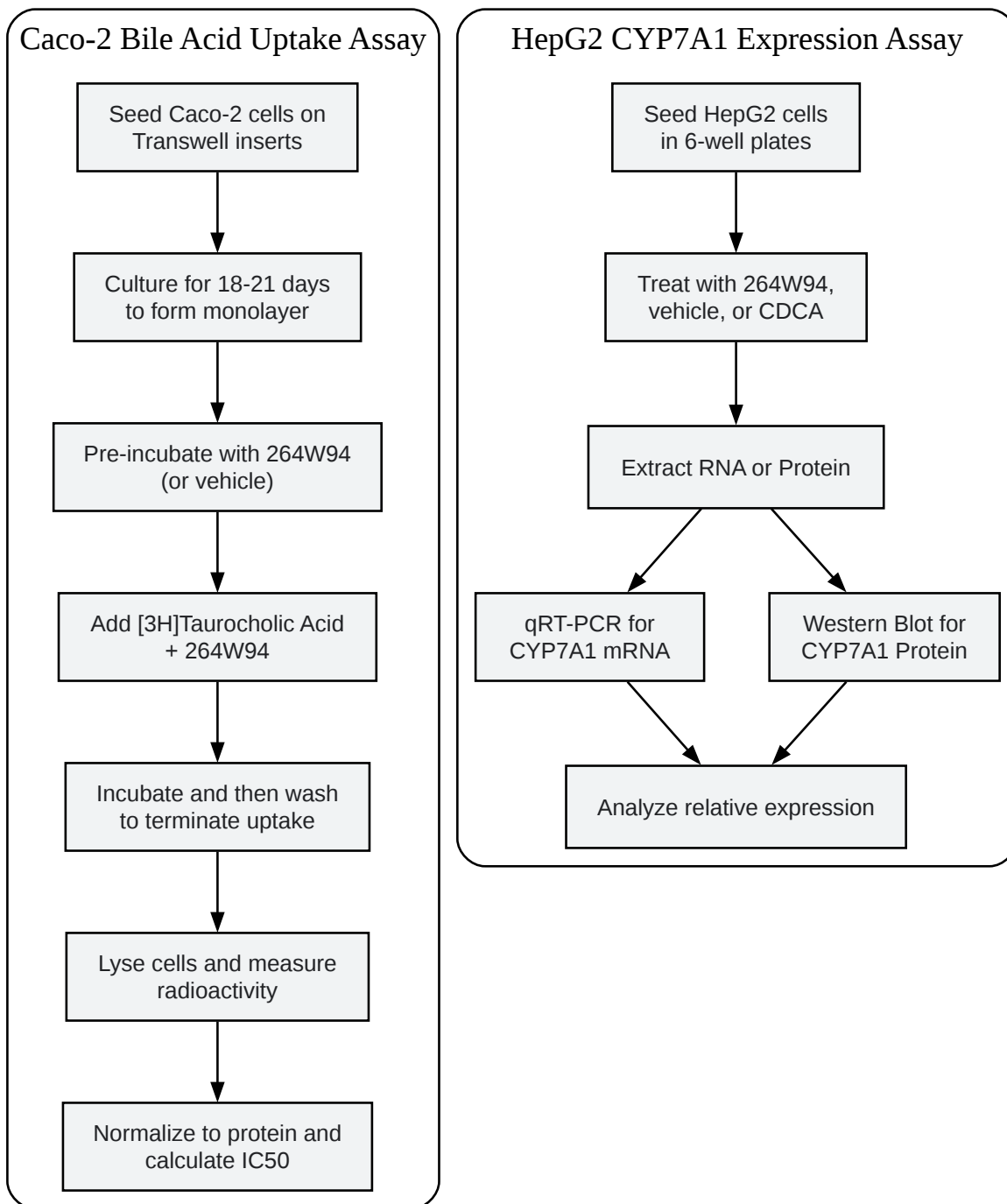

[Click to download full resolution via product page](#)

Caption: Experimental workflows for **264W94** cell-based assays.

Need Custom Synthesis?

BenchChem offers custom synthesis for rare earth carbides and specific isotopic labeling.

Email: info@benchchem.com or [Request Quote Online](#).

References

- 1. Ileal bile acid transporter inhibition, CYP7A1 induction, and antilipemic action of 264W94 - PubMed [pubmed.ncbi.nlm.nih.gov]
- 2. ASBT Transporter, ASBT Uptake Assay - Transporters - Solvo Biotechnology [solvobiotech.com]
- 3. Development of HepG2-derived cells expressing cytochrome P450s for assessing metabolism-associated drug-induced liver toxicity - PMC [pmc.ncbi.nlm.nih.gov]
- To cite this document: BenchChem. [Application Notes and Protocols for 264W94 in Cell Culture Assays]. BenchChem, [2026]. [Online PDF]. Available at: [https://www.benchchem.com/product/b1244617/docs#application-notes-and-protocols-for-264w94-in-cell-culture-assays]

Disclaimer & Data Validity:

The information provided in this document is for Research Use Only (RUO) and is strictly not intended for diagnostic or therapeutic procedures. While BenchChem strives to provide accurate protocols, we make no warranties, express or implied, regarding the fitness of this product for every specific experimental setup.

Technical Support: The protocols provided are for reference purposes. Unsure if this reagent suits your experiment?

Need Industrial/Bulk Grade? [Request Custom Synthesis Quote](#)

BenchChem

Our mission is to be the trusted global source of essential and advanced chemicals, empowering scientists and researchers to drive progress in science and industry.

Contact

Address: 3281 E Guasti Rd

Ontario, CA 91761, United States

Phone: (601) 213-4426

Email: info@benchchem.com

[Contact our Ph.D. Support Team for a compatibility check](#)