

# (+)-KDT501 Regulation of Gene Expression in Adipose Tissue: A Technical Guide

**Author:** BenchChem Technical Support Team. **Date:** April 2026

## Compound of Interest

Compound Name: (+)-KDT501

Cat. No.: B12432464

[Get Quote](#)

## Executive Summary

**(+)-KDT501** is a novel, stereochemically pure isohumulone derived from hops with demonstrated anti-diabetic and anti-inflammatory properties.[1][2] In adipose tissue, its mechanism of action is pleiotropic, primarily characterized by its activity as a weak, partial peroxisome proliferator-activated receptor  $\gamma$  (PPAR $\gamma$ ) agonist and a potent enhancer of  $\beta$ -adrenergic signaling.[1][3] This dual action results in a unique gene expression profile distinct from full PPAR $\gamma$  agonists like thiazolidinediones.[1][4] In human subcutaneous adipose tissue, **(+)-KDT501** treatment reduces the expression of genes involved in fatty acid synthesis and triglyceride formation.[3][5] Furthermore, it significantly potentiates the cold-induced expression of genes critical for thermogenesis and lipolysis.[3][6][7] These effects are coupled with an enhanced mitochondrial function in adipocytes and a post-transcriptional increase in adiponectin secretion, highlighting its potential as a therapeutic agent for metabolic syndrome. [3][7]

## Core Mechanisms of Action in Adipocytes

**(+)-KDT501** modulates adipocyte function through at least two primary signaling pathways, leading to a distinct profile of gene regulation.

## Partial Agonism of PPAR $\gamma$

Peroxisome proliferator-activated receptor  $\gamma$  (PPAR $\gamma$ ) is a master regulator of adipogenesis and lipid metabolism.[8][9] Full agonists, such as thiazolidinediones, robustly activate PPAR $\gamma$ , leading to broad changes in gene expression related to lipid storage and insulin sensitivity.[10][11] **(+)-KDT501** acts as a weak, partial PPAR $\gamma$  agonist.[1][2] This results in a more selective modulation of gene expression, promoting lipogenesis to a lesser extent than full agonists but still contributing to its anti-diabetic effects.[1][2] This selective modulation may avoid some of the side effects associated with full PPAR $\gamma$  activation.[8]

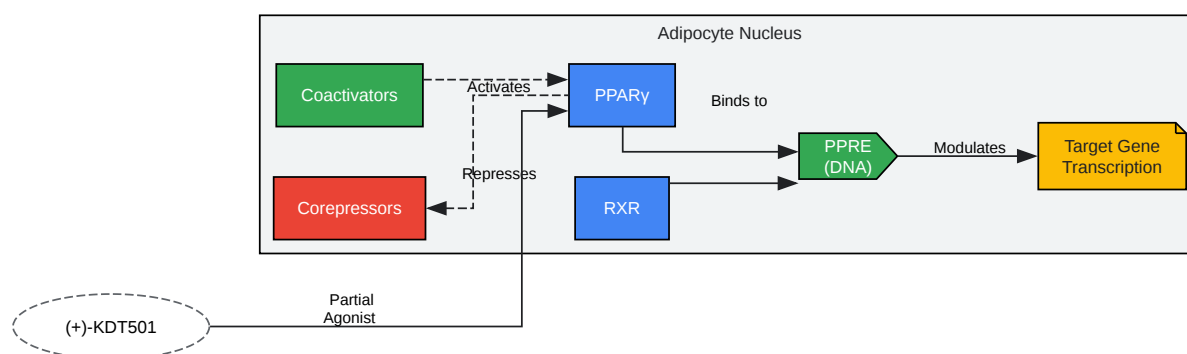

[Click to download full resolution via product page](#)

*Simplified PPAR $\gamma$  Signaling Pathway for (+)-KDT501.*

## Potentiation of $\beta$ -Adrenergic Signaling

In adipose tissue,  $\beta$ -adrenergic signaling, typically triggered by catecholamines in response to stimuli like cold, is crucial for initiating lipolysis and thermogenesis.[3] **(+)-KDT501** has been shown to significantly potentiate this pathway.[3][6][7] While not directly activating the receptor, it enhances the downstream cellular response to  $\beta$ -adrenergic stimuli. This leads to a more robust induction of thermogenic genes and greater mitochondrial fatty acid oxidation, particularly after a cold challenge.[3] This mechanism is consistent with observed increases in the expression of genes like PGC1 $\alpha$  and PPAR $\alpha$  in human adipose tissue following treatment.[3]

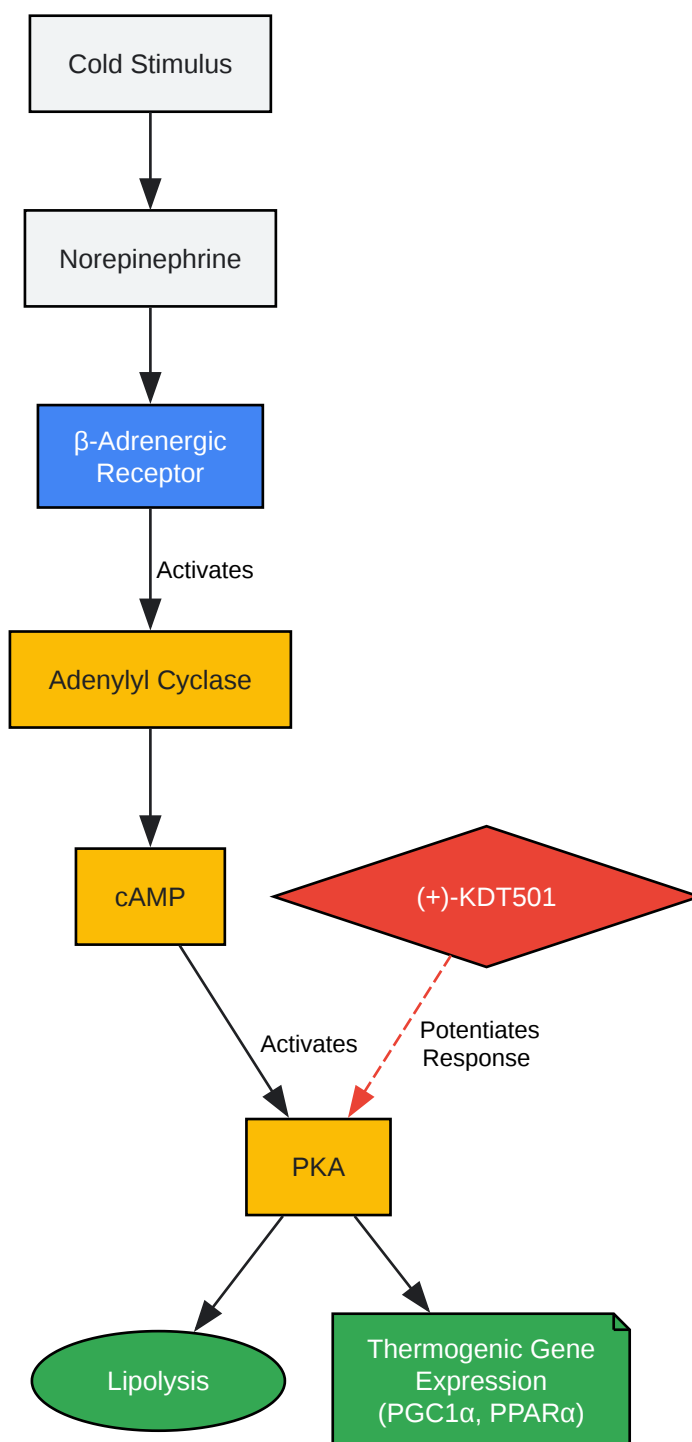

[Click to download full resolution via product page](#)

*Potential of β-Adrenergic Signaling by (+)-KDT501.*

## Regulation of Gene Expression in Adipose Tissue

Studies in obese, insulin-resistant human subjects have elucidated specific changes in subcutaneous white adipose tissue (SC WAT) gene expression following 28 days of **(+)-KDT501** treatment.[3]

## Effects on Basal Gene Expression

Under basal (non-cold-stimulated) conditions, **(+)-KDT501** treatment leads to a significant downregulation of key genes involved in lipid synthesis and storage.[3][5] This suggests a shift away from de novo lipogenesis and triglyceride formation in the resting state.

## Cold-Stimulated Gene Expression

The most pronounced effects of **(+)-KDT501** on gene expression were observed when treatment was combined with a cold stimulus.[3] This combination revealed an enhanced transcriptional response, strongly inducing genes associated with thermogenesis (beiging of white fat) and fat catabolism.[3][7] Before treatment, cold stimulus slightly decreased or had no effect on these genes; after treatment, the same stimulus caused a significant increase in their expression.[3]

## Data Summary

The following tables summarize the quantitative gene expression data from a phase II clinical trial involving nine obese, insulin-resistant participants.[3]

Table 1: Basal Gene Expression Changes in Human SC WAT After **(+)-KDT501** Treatment

Gene	Function	Fold Change	p-value	Citation
ACACA	Fatty Acid Synthesis	0.86	0.038	[3][5]
DGAT	Triglyceride Formation	0.87	0.043	[3][5]
LPL	Lipid & Lipoprotein Uptake	Tendency to decrease	0.068	[3][5]

| ADIPOQ | Adiponectin | Unchanged | N/A [3] |

Table 2: Cold-Stimulated Gene Expression Changes in Human SC WAT After (+)-KDT501 Treatment

Gene	Function	Observation	p-value	Citation
PGC1 $\alpha$	Thermogenesis, Mitochondrial Biogenesis	Expression increased with cold	< 0.05	[3]
TMEM26	Beige Adipocyte Marker	Expression increased with cold	< 0.05	[3]
PPAR $\alpha$	Fatty Acid Oxidation, Thermogenesis	Expression increased with cold	< 0.05	[3]
VEGF	Angiogenesis, Beiging	Expression increased with cold	< 0.01	[3]
LPL	Lipid & Lipoprotein Uptake	Expression increased with cold	N/A	[3]
PAI-1	Inhibitor of Fibrinolysis	Cold-induced increase was blunted	< 0.05	[3]

Note: p-values represent the significance of the differential response to cold before and after (+)-KDT501 treatment.

## Key Experimental Protocols

The findings described are supported by rigorous clinical and in vitro methodologies.

## In Vivo Analysis of Human Adipose Tissue Gene Expression

This protocol was central to understanding **(+)-KDT501**'s effects in a clinical setting.[\[3\]](#)[\[6\]](#)

- Study Design: A phase II clinical trial with nine obese participants characterized by prediabetes or metabolic syndrome.[\[3\]](#)[\[7\]](#)
- Intervention: Oral administration of **(+)-KDT501** for 28 days.[\[6\]](#)
- Tissue Sampling: Subcutaneous white adipose tissue (SC WAT) biopsies were performed on the abdomen before the treatment period and after its completion.[\[3\]](#)[\[6\]](#)
- Cold Stimulus Application: Before and after the 28-day treatment, an ice pack was applied to one side of the abdomen for 30 minutes. The post-stimulus biopsy was collected 4 hours later to assess the transcriptional response.[\[3\]](#)
- Gene Expression Quantification: Adipose tissue gene expression was analyzed using the Nanostring nCounter multiplex system, which measured the abundance of 130 genes related to adipose tissue function.[\[3\]](#)
- Statistical Analysis: A paired, two-tailed Student's t-test was used to compare gene expression before and after treatment and to analyze the differential response to the cold stimulus.[\[3\]](#)[\[7\]](#)

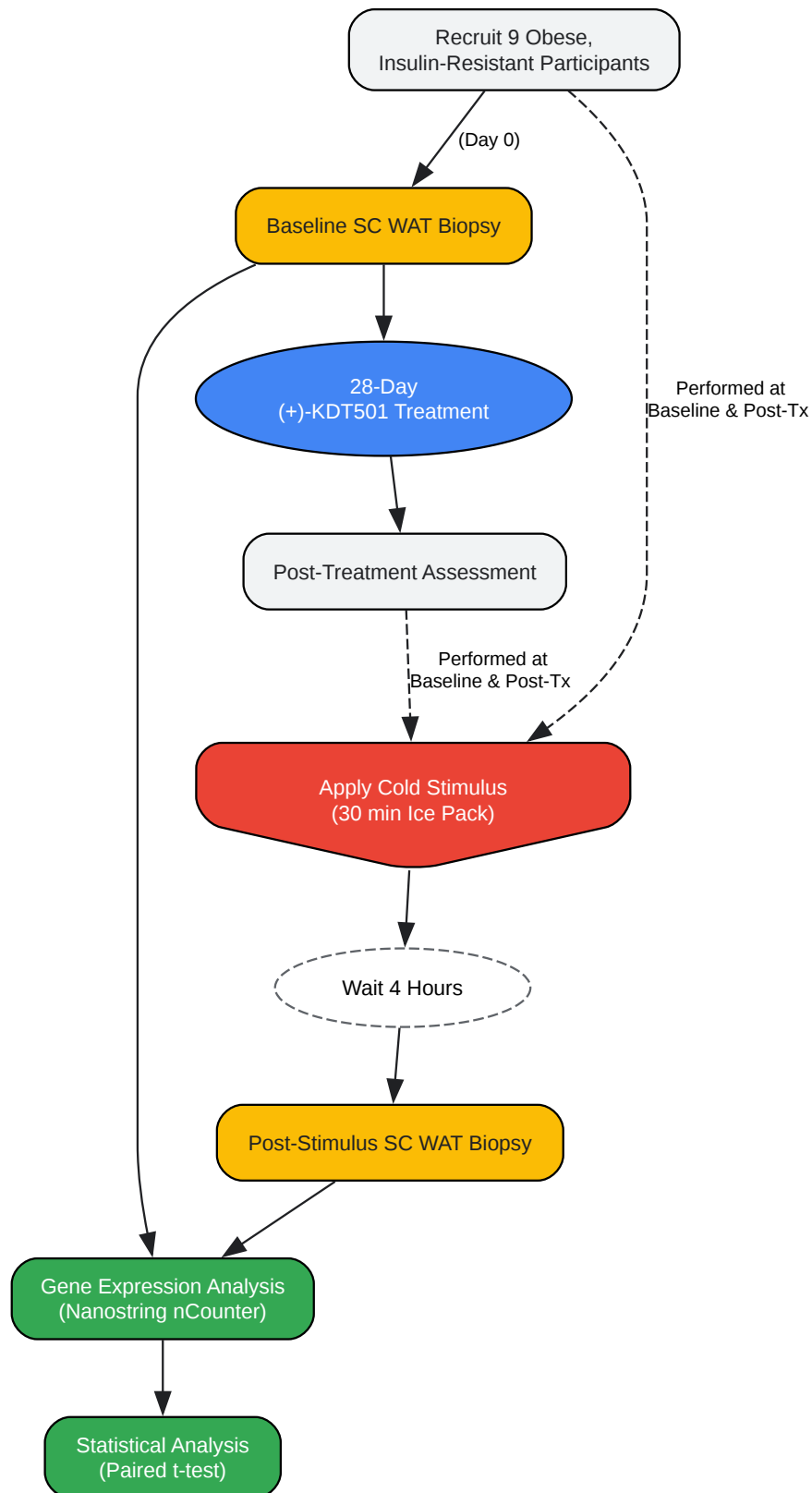

[Click to download full resolution via product page](#)

*Workflow for In Vivo Adipose Tissue Gene Expression Analysis.*

## In Vitro Lipogenesis Assay

This assay was used to confirm the partial PPAR $\gamma$  agonist activity of **(+)-KDT501**.[\[1\]](#)[\[2\]](#)

- Cell Models: Differentiated 3T3-L1 adipocytes and primary human subcutaneous adipocytes.  
[\[1\]](#)[\[2\]](#)
- Treatment: Cells were treated with various concentrations of **(+)-KDT501** (e.g., 3.125 to 25  $\mu$ M), a full agonist like rosiglitazone (1-10  $\mu$ M), or vehicle control for 6-10 days.[\[1\]](#)[\[2\]](#)
- Quantification: Intracellular lipid accumulation was quantified by extracting Oil Red O stain from the cells and measuring its absorbance. Data was expressed as fold induction compared to the vehicle control.[\[1\]](#)

## In Vitro Mitochondrial Function Assay

This protocol assessed the direct effects of **(+)-KDT501** on adipocyte energy metabolism.[\[3\]](#)

- Cell Model: Fully differentiated 3T3-L1 adipocytes.[\[3\]](#)
- Treatment: Cells were treated with **(+)-KDT501** for 48 hours.[\[3\]](#)
- Measurement: The rate of exogenous fatty acid oxidation was measured to determine both basal and maximal mitochondrial respiratory capacity.[\[3\]](#)

## Conclusion

**(+)-KDT501** presents a multifaceted approach to regulating gene expression in adipose tissue. Its status as a partial PPAR $\gamma$  agonist allows for a nuanced modulation of lipogenic genes, differing significantly from full agonists.[\[1\]](#)[\[4\]](#) Critically, its ability to potentiate  $\beta$ -adrenergic signaling primes adipocytes for a robust thermogenic and lipolytic response to stimuli, a highly desirable trait for combating metabolic disease.[\[3\]](#)[\[7\]](#) The in vivo data from human subjects, showing decreased expression of lipid synthesis genes at baseline and increased expression of thermogenic genes upon stimulation, provides strong evidence for its potential to remodel adipose tissue function beneficially.[\[3\]](#) These unique transcriptional effects, combined with enhanced mitochondrial function and increased adiponectin secretion, position **(+)-KDT501** as a promising candidate for further development in the treatment of obesity and type 2 diabetes.

### Need Custom Synthesis?

BenchChem offers custom synthesis for rare earth carbides and specific isotopic labeling.

Email: [info@benchchem.com](mailto:info@benchchem.com) or [Request Quote Online](#).

## References

- 1. KDT501, a Derivative from Hops, Normalizes Glucose Metabolism and Body Weight in Rodent Models of Diabetes - PMC [[pmc.ncbi.nlm.nih.gov](https://pubmed.ncbi.nlm.nih.gov/)]
- 2. [pdfs.semanticscholar.org](https://pdfs.semanticscholar.org/) [[pdfs.semanticscholar.org](https://pdfs.semanticscholar.org/)]
- 3. The Influence of a KDT501, a Novel Isohumulone, on Adipocyte Function in Humans - PMC [[pmc.ncbi.nlm.nih.gov](https://pubmed.ncbi.nlm.nih.gov/)]
- 4. KDT501, a derivative from hops, normalizes glucose metabolism and body weight in rodent models of diabetes - PubMed [[pubmed.ncbi.nlm.nih.gov](https://pubmed.ncbi.nlm.nih.gov/)]
- 5. [researchgate.net](https://researchgate.net/) [[researchgate.net](https://researchgate.net/)]
- 6. The Influence of a KDT501, a Novel Isohumulone, on Adipocyte Function in Humans - PubMed [[pubmed.ncbi.nlm.nih.gov](https://pubmed.ncbi.nlm.nih.gov/)]
- 7. Frontiers | The Influence of a KDT501, a Novel Isohumulone, on Adipocyte Function in Humans [[frontiersin.org](https://frontiersin.org/)]
- 8. Selective Modulators of PPAR- $\gamma$  Activity: Molecular Aspects Related to Obesity and Side-Effects - PMC [[pmc.ncbi.nlm.nih.gov](https://pubmed.ncbi.nlm.nih.gov/)]
- 9. Deciphering the Roles of PPAR $\gamma$  in Adipocytes via Dynamic Change of Transcription Complex - PMC [[pmc.ncbi.nlm.nih.gov](https://pubmed.ncbi.nlm.nih.gov/)]
- 10. PPAR $\gamma$  regulates adipocyte cholesterol metabolism via oxidized LDL receptor 1 - PMC [[pmc.ncbi.nlm.nih.gov](https://pubmed.ncbi.nlm.nih.gov/)]
- 11. [mdpi.com](https://mdpi.com/) [[mdpi.com](https://mdpi.com/)]
- To cite this document: BenchChem. [(+)-KDT501 Regulation of Gene Expression in Adipose Tissue: A Technical Guide]. BenchChem, [2026]. [Online PDF]. Available at: [<https://www.benchchem.com/product/b12432464/docs#kdt501-regulation-of-gene-expression-in-adipose-tissue-a-technical-guide>]

---

### Disclaimer & Data Validity:

The information provided in this document is for Research Use Only (RUO) and is strictly not intended for diagnostic or therapeutic procedures. While BenchChem strives to provide accurate protocols, we make no warranties, express or implied, regarding the fitness of this product for every specific experimental setup.

**Technical Support:** The protocols provided are for reference purposes. Unsure if this reagent suits your experiment?

**Need Industrial/Bulk Grade?** [Request Custom Synthesis Quote](#)

## BenchChem

Our mission is to be the trusted global source of essential and advanced chemicals, empowering scientists and researchers to drive progress in science and industry.

### Contact

Address: 3281 E Guasti Rd  
Ontario, CA 91761, United States  
Phone: (601) 213-4426  
Email: [info@benchchem.com](mailto:info@benchchem.com)

[Contact our Ph.D. Support Team for a compatibility check](#)