

Application Notes and Protocols for Detecting pThr3-CDK5 Substrate Phosphorylation

Author: BenchChem Technical Support Team. **Date:** April 2026

Compound of Interest

Compound Name: [pThr3]-CDK5 Substrate

Cat. No.: B12431532

[Get Quote](#)

For Researchers, Scientists, and Drug Development Professionals

This document provides a detailed protocol for the detection of phosphorylated Threonine 3 (pThr3) on Cyclin-Dependent Kinase 5 (CDK5) substrates using Western blotting. This method is crucial for researchers investigating CDK5 signaling pathways, identifying novel CDK5 substrates, and screening for potential therapeutic inhibitors of CDK5 activity in various contexts, including neurodegenerative diseases and cancer.[\[1\]](#)[\[2\]](#)

Introduction

Cyclin-Dependent Kinase 5 (CDK5) is a unique member of the CDK family, primarily active in post-mitotic neurons. Its activity is tightly regulated by its binding to activators p35 or p39.[\[1\]](#)[\[2\]](#) Dysregulation of CDK5 activity has been implicated in a variety of neurodegenerative disorders such as Alzheimer's and Parkinson's disease.[\[1\]](#)[\[2\]](#) CDK5 is a proline-directed serine/threonine kinase, and a significant portion of its substrates are phosphorylated on a threonine residue, often at position 3 within a specific consensus motif.[\[1\]](#)[\[3\]](#)[\[4\]](#) The detection of specific phosphorylation events is a direct measure of kinase activity and is essential for understanding the cellular functions of CDK5.[\[1\]](#)

This protocol details the materials and methods required for the sensitive and specific detection of pThr3-CDK5 substrate phosphorylation in cell lysates and tissue samples by Western blot.

Signaling Pathway for CDK5-Mediated Substrate Phosphorylation

The following diagram illustrates the canonical signaling pathway leading to the phosphorylation of substrates by CDK5.

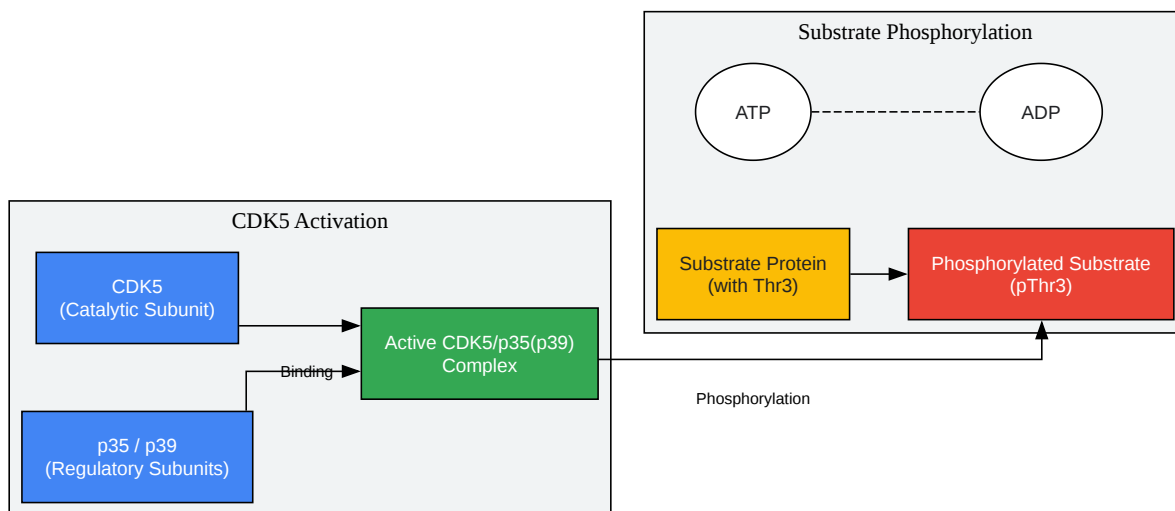

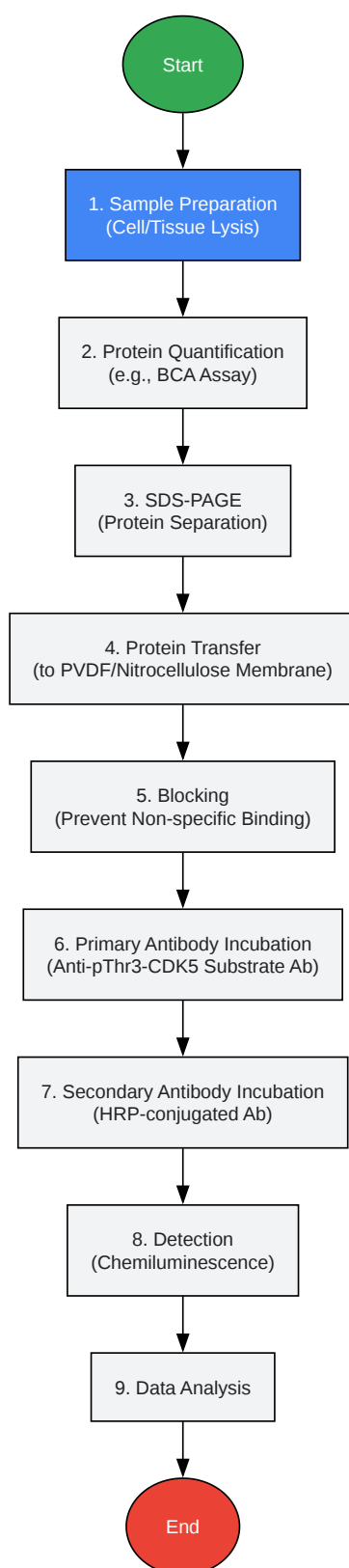

[Click to download full resolution via product page](#)

Need Custom Synthesis?

BenchChem offers custom synthesis for rare earth carbides and specific isotopic labeling.

Email: info@benchchem.com or [Request Quote Online](#).

References

- [1. Protocols for Characterization of Cdk5 Kinase Activity - PMC \[pmc.ncbi.nlm.nih.gov\]](#)
- [2. researchgate.net \[researchgate.net\]](#)
- [3. Phospho-CDK Substrate Motif \[\(K/H\)pSP\] MultiMab® Rabbit mAb mix | Cell Signaling Technology \[cellsignal.com\]](#)
- [4. Phospho-\(Ser/Thr\) Kinase Substrate Antibody Sampler Kit | Cell Signaling Technology \[cellsignal.com\]](#)
- To cite this document: BenchChem. [Application Notes and Protocols for Detecting pThr3-CDK5 Substrate Phosphorylation]. BenchChem, [2026]. [Online PDF]. Available at: [\[https://www.benchchem.com/product/b12431532/docs#application-notes-and-protocols-for-detecting-pthr3-cdk5-substrate-phosphorylation\]](https://www.benchchem.com/product/b12431532/docs#application-notes-and-protocols-for-detecting-pthr3-cdk5-substrate-phosphorylation)

Disclaimer & Data Validity:

The information provided in this document is for Research Use Only (RUO) and is strictly not intended for diagnostic or therapeutic procedures. While BenchChem strives to provide accurate protocols, we make no warranties, express or implied, regarding the fitness of this product for every specific experimental setup.

Technical Support: The protocols provided are for reference purposes. Unsure if this reagent suits your experiment?

Need Industrial/Bulk Grade? [Request Custom Synthesis Quote](#)

BenchChem

Our mission is to be the trusted global source of essential and advanced chemicals, empowering scientists and researchers to drive progress in science and industry.

Contact

Address: 3281 E Guasti Rd
Ontario, CA 91761, United States
Phone: (601) 213-4426
Email: info@benchchem.com

[Contact our Ph.D. Support Team for a compatibility check](#)