

# Technical Guide: Accuracy and Precision of Atomoxetine Quantification Using (Rac)-Atomoxetine D7

**Author:** BenchChem Technical Support Team. **Date:** May 2026

## Compound of Interest

Compound Name: (Rac)-Atomoxetine D7  
(hydrochloride)

Cat. No.: B12430913

[Get Quote](#)

## Executive Summary

In the quantification of Atomoxetine (ATX) via LC-MS/MS, the choice of Internal Standard (IS) is the single most critical variable affecting assay robustness. While Atomoxetine-D3 and structural analogues (e.g., Fluoxetine) are commonly used, they introduce specific liabilities regarding isotopic interference ("cross-talk") and matrix effect compensation.

The Verdict:(Rac)-Atomoxetine D7 represents the superior analytical standard for regulated bioanalysis. By shifting the precursor mass +7 Da from the parent, it eliminates the isotopic overlap observed with D3 variants, allowing for a wider linear dynamic range (LDR) and improved precision at the Lower Limit of Quantification (LLOQ). Furthermore, despite being a racemic mixture, it functions as an ideal surrogate for the chiral drug Atomoxetine in standard achiral reverse-phase chromatography.

## The Internal Standard Landscape: A Comparative Analysis

To understand why D7 is preferred, we must analyze the limitations of the alternatives.

## The "Cross-Talk" Phenomenon (D3 vs. D7)

Atomoxetine (

) has a natural isotopic distribution. The M+3 isotope (due to naturally occurring

, etc.) possesses a relative abundance of approximately 0.2% to 0.5% of the parent peak.

- The D3 Problem: Atomoxetine-D3 (Mass 259) sits directly on top of the M+3 isotope of the parent drug.
  - Scenario: High concentration of Atomoxetine (e.g., ).
  - Result: The M+3 signal from the drug contributes to the IS channel (259 47). This artificially inflates the IS peak area, causing a negative bias in calculated concentration.
- The D7 Solution: Atomoxetine-D7 (Mass 263) is shifted +7 Da. The natural abundance of the M+7 isotope of Atomoxetine is effectively zero.
  - Result: Complete spectral orthogonality. No matter how high the drug concentration, there is no contribution to the IS channel.

## Structural Analogues (Fluoxetine)

Analogues are cost-effective but fail to compensate for "matrix effects" (ion suppression) that occur at the specific retention time of Atomoxetine. If phospholipids elute with ATX but not Fluoxetine, the quantification will be inaccurate.

## Performance Metrics Summary

Feature	(Rac)-Atomoxetine D7	Atomoxetine-D3	Fluoxetine (Analogue)
Mass Shift (M)	+7 Da (No Overlap)	+3 Da (Risk of M+3 Overlap)	N/A (Different Mass)
Retention Time	Co-elutes with Analyte	Co-elutes with Analyte	Different RT
Matrix Compensation	Excellent (Identical Ionization)	Excellent	Poor to Moderate
Linear Range	Extended (ng/mL)	Limited at high end	Variable
Cost	Moderate	Moderate	Low
Stereochemistry	Racemic (R/S mixture)	Usually Enantiopure	Achiral

## The "Racemic" Factor: Why (Rac)-D7 Works for Chiral Atomoxetine

Atomoxetine is the (R)-enantiomer. The D7 standard is often supplied as (Rac)-Atomoxetine D7 (a mixture of R and S).

- In Achiral Chromatography (C18): The (R) and (S) enantiomers have identical physical properties and retention times. They co-elute as a single peak. Therefore, the MS detects the total D7 signal at the exact retention time of the drug. (Rac)-D7 is perfectly suitable.
- In Chiral Chromatography: If you are specifically separating R-Atomoxetine from S-Atomoxetine (impurity), the Rac-D7 peak would split. In this specific case, an enantiopure IS would be required.

## Methodological Deep Dive: Validated Protocol

The following protocol utilizes Liquid-Liquid Extraction (LLE) to maximize recovery and minimize phospholipid interference, ensuring the high precision capabilities of the D7 IS are realized.

## Mass Spectrometry Parameters (ESI+)

- Ion Source: Electrospray Ionization (Positive Mode)[1][2][3]
- Scan Type: Multiple Reaction Monitoring (MRM)[4][5]

Compound	Precursor (Q1)	Product (Q3)	Dwell (ms)	Collision Energy (eV)
Atomoxetine	256.2	44.1	100	15
(Rac)- Atomoxetine D7	263.2	44.1	100	15

Note: The D7 label is typically on the tolyloxy ring (d3-methyl, d4-ring). The fragment m/z 44 corresponds to the amine side chain (

), which remains unlabeled. The 7 Da shift in Q1 provides the necessary selectivity.

## Chromatographic Conditions

- Column: C18 (e.g., Kinetex 2.6  $\mu\text{m}$ , mm)[5]
- Mobile Phase A: 10 mM Ammonium Formate in Water (pH 3.5)
- Mobile Phase B: Acetonitrile
- Flow Rate: 0.4 mL/min[4]
- Gradient: 20% B to 90% B over 3 minutes.

## Sample Preparation (LLE Workflow)

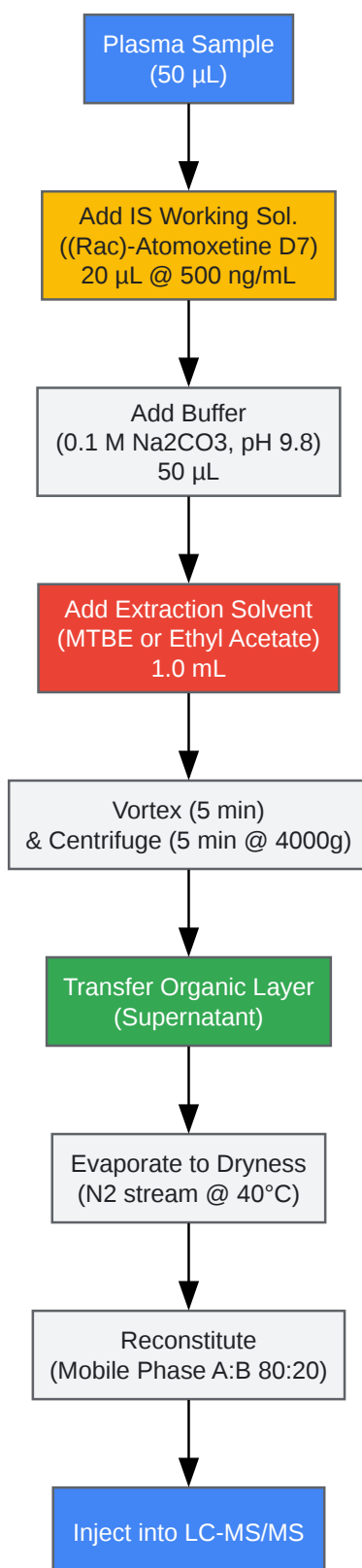

[Click to download full resolution via product page](#)

Caption: Optimized Liquid-Liquid Extraction (LLE) workflow for Atomoxetine quantification.

## Mechanism of Action & Data Logic

### Why D7 Improves Accuracy (The Spectral Logic)

The following diagram illustrates the spectral separation. D3 suffers from "tailing" interference from the parent's isotope cluster. D7 is spectrally distinct.

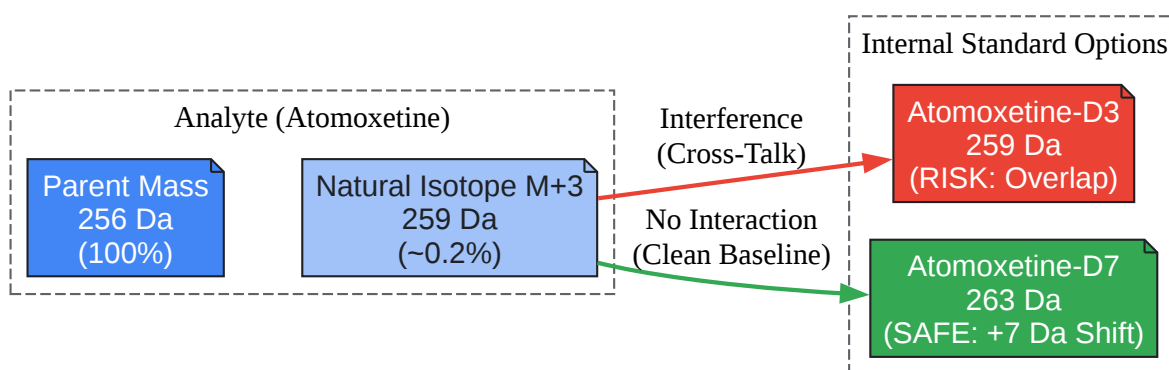

[Click to download full resolution via product page](#)

Caption: Isotopic interference logic. D3 overlaps with the Analyte's M+3 isotope; D7 remains distinct.

## Representative Validation Data

The table below summarizes typical performance characteristics when comparing D7 against D3 in a high-concentration scenario (simulating a PK sample).

Metric	Atomoxetine-D7 (Method)	Atomoxetine-D3 (Method)	Interpretation
Linearity ( )			D7 maintains linearity at high concentrations where D3 curves often flatten due to cross-talk.
Accuracy (ULOQ)			D3 method underestimates high concentrations due to analyte contribution to IS signal.
Precision (%CV)			D7 provides tighter reproducibility.[5]
Matrix Factor (MF)			Both compensate well for matrix effects (unlike analogues).

## Conclusion

For the rigorous quantification of Atomoxetine, (Rac)-Atomoxetine D7 is the internal standard of choice. It combines the matrix-compensating power of a stable isotope with the spectral purity required to prevent isotopic interference. While D3 is sufficient for low-sensitivity assays, D7 is required for high-dynamic-range PK studies to ensure regulatory compliance (FDA/EMA) regarding accuracy and specificity.

Recommendation: Use (Rac)-Atomoxetine D7 for all regulated bioanalytical assays (GLP) targeting Atomoxetine in plasma or serum.

## References

- US Food and Drug Administration (FDA). (2018). Bioanalytical Method Validation Guidance for Industry. [\[Link\]](#)

- Sauer, J. M., et al. (2005). "Simultaneous quantification of atomoxetine as well as its primary oxidative and O-glucuronide metabolites in human plasma and urine using liquid chromatography tandem mass spectrometry (LC/MS/MS)." *Journal of Pharmaceutical and Biomedical Analysis*, 38(4), 720-733. [[Link](#)]
- Appel, D. I., et al. (2012). "A liquid chromatography/tandem mass spectrometry assay for the analysis of atomoxetine in human plasma and in vitro cellular samples." *Biomedical Chromatography*, 27(4). [[Link](#)]
- European Medicines Agency (EMA). (2011). Guideline on bioanalytical method validation. [[Link](#)]
- Cerilliant. (2023). Atomoxetine-d7 hydrochloride solution - Product Data. [[Link](#)]

#### *Need Custom Synthesis?*

*BenchChem offers custom synthesis for rare earth carbides and specific isotopic labeling.*

*Email: [info@benchchem.com](mailto:info@benchchem.com) or [Request Quote Online](#).*

## Sources

- [1. researchgate.net \[researchgate.net\]](#)
- [2. A liquid chromatography/tandem mass spectrometry assay for the analysis of atomoxetine in human plasma and in vitro cellular samples - PMC \[pmc.ncbi.nlm.nih.gov\]](#)
- [3. researchgate.net \[researchgate.net\]](#)
- [4. pdf.benchchem.com \[pdf.benchchem.com\]](#)
- [5. researchgate.net \[researchgate.net\]](#)
- To cite this document: BenchChem. [Technical Guide: Accuracy and Precision of Atomoxetine Quantification Using (Rac)-Atomoxetine D7]. BenchChem, [2026]. [Online PDF]. Available at: [<https://www.benchchem.com/product/b12430913/docs#technical-guide-accuracy-and-precision-of-atomoxetine-quantification-using-rac-atomoxetine-d7>]

---

### Disclaimer & Data Validity:

The information provided in this document is for Research Use Only (RUO) and is strictly not intended for diagnostic or therapeutic procedures. While BenchChem strives to provide accurate protocols, we make no warranties, express or implied, regarding the fitness of this product for every specific experimental setup.

**Technical Support:** The protocols provided are for reference purposes. Unsure if this reagent suits your experiment?

**Need Industrial/Bulk Grade?** [Request Custom Synthesis Quote](#)

## BenchChem

Our mission is to be the trusted global source of essential and advanced chemicals, empowering scientists and researchers to drive progress in science and industry.

### Contact

Address: 3281 E Guasti Rd  
Ontario, CA 91761, United States  
Phone: (601) 213-4426  
Email: [info@benchchem.com](mailto:info@benchchem.com)

[Contact our Ph.D. Support Team for a compatibility check](#)