

# TAN-67: Application Notes and Protocols for Researchers

**Author:** BenchChem Technical Support Team. **Date:** April 2026

## Compound of Interest

Compound Name: TAN-67  
Cat. No.: B1243400

[Get Quote](#)

For researchers, scientists, and drug development professionals, this document provides detailed application notes and protocols for the use of **TAN-67**, a potent and selective non-peptidic  $\delta$ -opioid receptor agonist.

## Introduction

**TAN-67** is a valuable research tool for investigating the role of the  $\delta$ -opioid receptor in various physiological and pathological processes. Its non-peptide structure offers advantages in terms of metabolic stability and potential for oral bioavailability compared to endogenous peptide ligands. This document outlines the solubility characteristics of **TAN-67**, provides a detailed protocol for preparing an injectable vehicle for in vivo studies, and describes its primary signaling pathway.

## Data Presentation: TAN-67 Solubility

The solubility of **TAN-67** is a critical factor for its application in in vitro and in vivo experiments. The dihydrobromide salt of **TAN-67** exhibits good solubility in aqueous solutions and polar aprotic solvents.

Solvent	Solubility
Water	Up to 100 mM
Dimethyl Sulfoxide (DMSO)	Up to 100 mM
Phosphate-Buffered Saline (PBS)	Expected to be similar to water, but should be empirically determined for the specific experimental concentration.
Ethanol	Data not readily available. Miscibility with aqueous buffers should be considered.

Note: It is always recommended to perform a small-scale solubility test before preparing a large batch of a solution. The solubility can be affected by temperature, pH, and the presence of other solutes.

## Experimental Protocols

### Preparation of TAN-67 Vehicle for Intravenous Injection

This protocol provides a general method for preparing a sterile saline solution of **TAN-67** suitable for intravenous administration in preclinical animal models.

Materials:

- **TAN-67** dihydrobromide
- Sterile, pyrogen-free 0.9% Sodium Chloride Injection, USP (Normal Saline)
- Sterile, pyrogen-free water for injection (optional, for initial dissolution of high concentrations)
- Sterile vials
- Sterile syringe filters (0.22  $\mu\text{m}$  pore size)
- Sterile syringes and needles
- Vortex mixer

- Calibrated balance
- pH meter and sterile pH adjustment solutions (e.g., 0.1 N HCl, 0.1 N NaOH) (optional, if pH adjustment is necessary)

Procedure:

- Calculate the required amount of **TAN-67** and vehicle. Based on the desired final concentration and total volume, calculate the mass of **TAN-67** dihydrobromide needed.
- Weigh **TAN-67**. Accurately weigh the calculated amount of **TAN-67** dihydrobromide powder using a calibrated balance in a clean, draft-free environment.
- Dissolve **TAN-67**.
  - Aseptically add the weighed **TAN-67** powder to a sterile vial.
  - Add a small volume of sterile normal saline (or sterile water for injection if a higher initial concentration is needed before final dilution).
  - Gently vortex the vial until the powder is completely dissolved. Visually inspect the solution to ensure there are no undissolved particulates.
- Adjust to the final volume. Once dissolved, add sterile normal saline to reach the final desired volume.
- Check and adjust pH (if necessary). For intravenous injections, the pH of the final solution should ideally be close to physiological pH (~7.4). If the dissolved compound significantly alters the pH, it can be adjusted using sterile, dilute acid or base. This step should be performed with caution to avoid precipitation of the compound.
- Sterile filter the solution. Draw the final solution into a sterile syringe. Attach a sterile 0.22  $\mu\text{m}$  syringe filter to the syringe and filter the solution into a final sterile vial. This step removes any potential microbial contamination.
- Storage. Store the sterile **TAN-67** solution at an appropriate temperature, protected from light. For short-term storage, 2-8°C is often suitable. For long-term storage, aliquoting and

freezing at  $-20^{\circ}\text{C}$  or  $-80^{\circ}\text{C}$  may be necessary, but freeze-thaw stability should be considered.

#### Safety Precautions:

- Always handle **TAN-67** and prepare solutions in a well-ventilated area, preferably a chemical fume hood.
- Wear appropriate personal protective equipment (PPE), including gloves, a lab coat, and safety glasses.
- Follow all institutional guidelines for the safe handling of chemical compounds and for aseptic techniques.

## Mandatory Visualization

### TAN-67 Signaling Pathway

**TAN-67** exerts its effects by acting as an agonist at the  $\delta$ -opioid receptor, which is a G-protein coupled receptor (GPCR). The primary signaling cascade initiated by **TAN-67** binding is through the inhibitory G-protein,  $G_i/o$ .

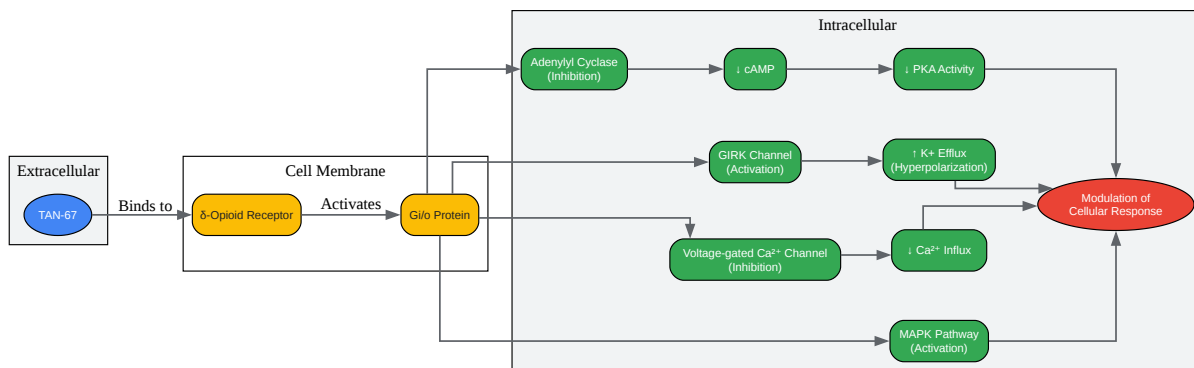

[Click to download full resolution via product page](#)

Caption: **TAN-67** activates the  $\delta$ -opioid receptor, leading to downstream signaling cascades.

## Experimental Workflow for In Vivo Injection

The following diagram outlines the general workflow for preparing and administering **TAN-67** for in vivo experiments.

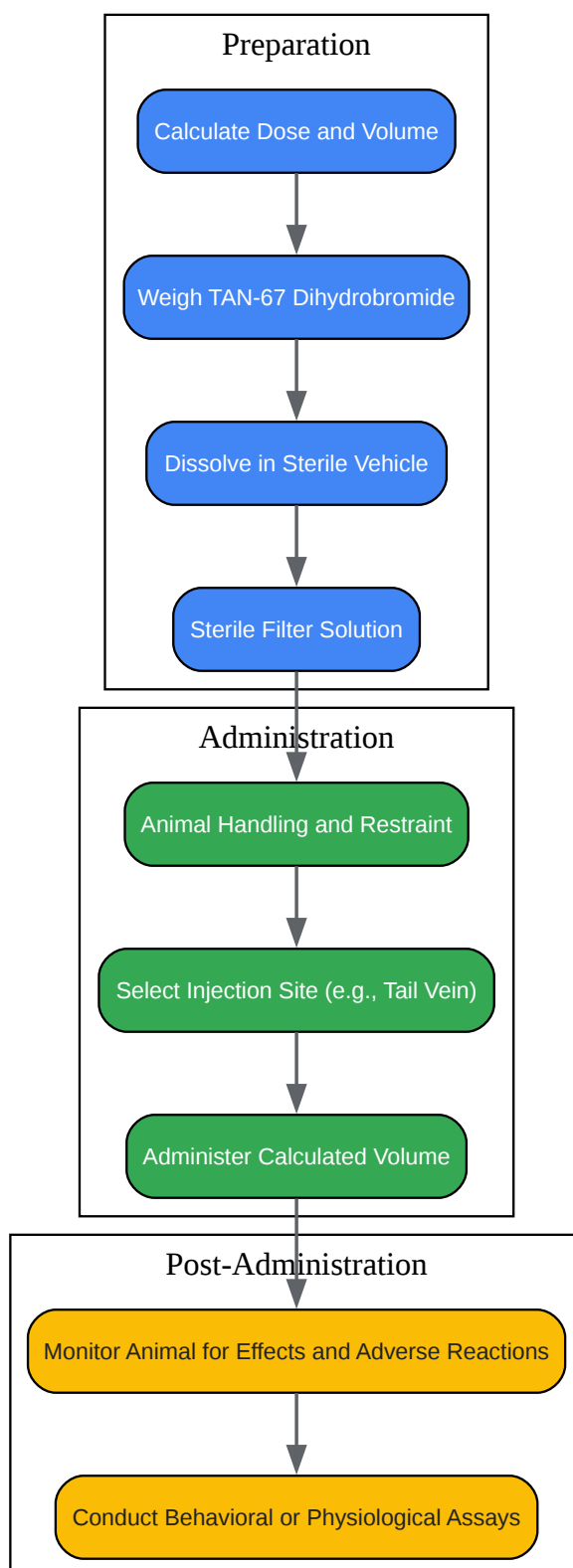

[Click to download full resolution via product page](#)

Caption: A generalized workflow for the preparation and in vivo administration of **TAN-67**.

- To cite this document: BenchChem. [TAN-67: Application Notes and Protocols for Researchers]. BenchChem, [2026]. [Online PDF]. Available at: [<https://www.benchchem.com/product/b1243400/docs#tan-67-application-notes-and-protocols-for-researchers>]

---

### Disclaimer & Data Validity:

The information provided in this document is for Research Use Only (RUO) and is strictly not intended for diagnostic or therapeutic procedures. While BenchChem strives to provide accurate protocols, we make no warranties, express or implied, regarding the fitness of this product for every specific experimental setup.

**Technical Support:** The protocols provided are for reference purposes. Unsure if this reagent suits your experiment?

**Need Industrial/Bulk Grade?** [Request Custom Synthesis Quote](#)

## BenchChem

Our mission is to be the trusted global source of essential and advanced chemicals, empowering scientists and researchers to drive progress in science and industry.

### Contact

Address: 3281 E Guasti Rd  
Ontario, CA 91761, United States  
Phone: (601) 213-4426  
Email: [info@benchchem.com](mailto:info@benchchem.com)

[Contact our Ph.D. Support Team for a compatibility check](#)