

# Application Notes and Protocols for Aqueous Wittig Reaction Using Triphenylphosphonium Chloride

**Author:** BenchChem Technical Support Team. **Date:** May 2026

## Compound of Interest

Compound Name: *Triphenylphosphonium chloride*

Cat. No.: *B1243017*

[Get Quote](#)

For Researchers, Scientists, and Drug Development Professionals

## Introduction

The Wittig reaction is a cornerstone of organic synthesis, enabling the reliable formation of carbon-carbon double bonds from carbonyl compounds. Traditionally performed in anhydrous organic solvents, recent advancements have led to the development of aqueous protocols. These "green" methodologies offer significant advantages, including reduced environmental impact, simplified procedures, and often, enhanced reaction rates and selectivities. This document provides detailed application notes and protocols for conducting the Wittig reaction in an aqueous medium using **triphenylphosphonium chloride** derivatives. The protocols are particularly relevant for researchers in drug development and other fields where sustainable and efficient synthetic methods are paramount.

## Core Concepts

The aqueous Wittig reaction typically involves the in situ or pre-formed generation of a phosphorus ylide from a triphenylphosphonium salt in the presence of a base. The ylide then

reacts with an aldehyde or ketone to yield an alkene and triphenylphosphine oxide. The use of water as a solvent is facilitated by the solubility of the phosphonium salt and the base in the aqueous phase. The hydrophobic effect can also play a role in promoting the reaction between the organic substrates.

## Reaction Mechanism

The generally accepted mechanism for the Wittig reaction in an aqueous medium proceeds through the following key steps:

- **Ylide Formation:** The phosphonium salt is deprotonated by a base (e.g., NaOH, NaHCO<sub>3</sub>) to form the phosphorus ylide.
- **Oxaphosphetane Formation:** The nucleophilic ylide attacks the carbonyl carbon of the aldehyde or ketone in a [2+2] cycloaddition to form a four-membered ring intermediate called an oxaphosphetane.
- **Alkene Formation:** The unstable oxaphosphetane collapses, yielding the final alkene product and triphenylphosphine oxide. The formation of the highly stable phosphorus-oxygen double bond in triphenylphosphine oxide is a major driving force for the reaction.

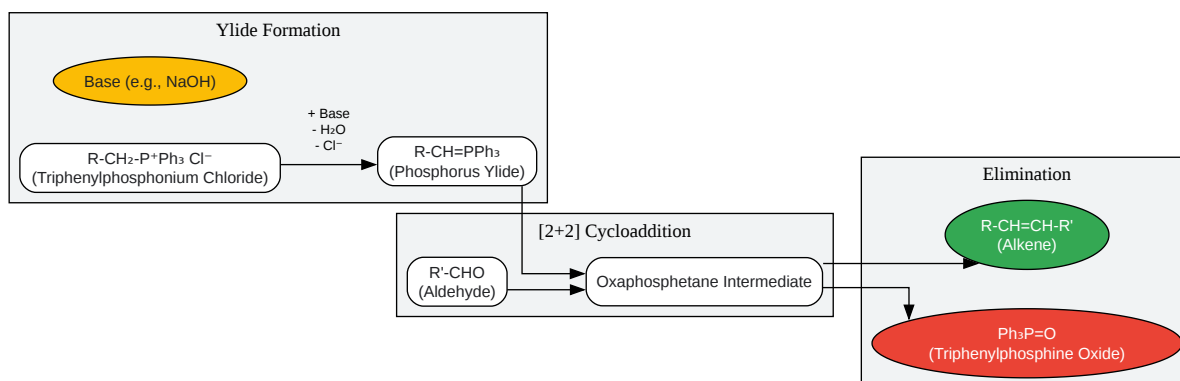

[Click to download full resolution via product page](#)

**Caption:** General mechanism of the aqueous Wittig reaction.

## Experimental Protocols

Two primary protocols for the aqueous Wittig reaction are presented below, differing in the choice of base and reaction setup.

### Protocol 1: One-Pot Aqueous Wittig Reaction with Sodium Bicarbonate

This protocol is a versatile and environmentally friendly method that utilizes a weak base in a one-pot setup.

Materials:

- Triphenylphosphine ( $Ph_3P$ )
- Alkyl halide (e.g., methyl bromoacetate, bromoacetonitrile)

- Aldehyde (e.g., benzaldehyde, 2-thiophenecarboxaldehyde, anisaldehyde)
- Saturated aqueous sodium bicarbonate ( $\text{NaHCO}_3$ ) solution
- Diethyl ether
- 1.0 M Sulfuric acid ( $\text{H}_2\text{SO}_4$ )
- Magnesium sulfate ( $\text{MgSO}_4$ )
- Silica gel for column chromatography
- Hexanes and Ethyl acetate for eluent

Procedure:

- To a test tube equipped with a magnetic stir bar, add freshly ground triphenylphosphine.
- Add 5 mL of a saturated aqueous solution of sodium bicarbonate and stir the suspension for 1 minute.
- To the suspension, add the alkyl halide followed by the aldehyde.
- Stir the reaction mixture vigorously for 1 hour at room temperature.
- After 1 hour, quench the reaction by adding 40 drops of 1.0 M  $\text{H}_2\text{SO}_4$  (aq).
- Extract the mixture with diethyl ether.
- Dry the combined organic extracts with magnesium sulfate, filter, and concentrate in vacuo.
- Purify the crude product by column chromatography on silica gel.

## Protocol 2: Aqueous Wittig Reaction with Sodium Hydroxide

This protocol is effective for a wide range of aromatic aldehydes and is typically completed within a short reaction time.[1]

#### Materials:

- Aromatic aldehyde
- **Benzyltriphenylphosphonium chloride**
- 10% (w/v) Sodium hydroxide (NaOH) solution or 50% (w/w) NaOH solution
- Dichloromethane (for extraction, if necessary)
- 95% Ethanol (for recrystallization)

#### Procedure:

- In a suitable flask, combine the aromatic aldehyde and **benzyltriphenylphosphonium chloride**.
- Add the sodium hydroxide solution to the mixture.
- Stir the reaction vigorously at room temperature for 30 minutes or reflux for 2 hours, depending on the substrate and desired yield.<sup>[1][2]</sup>
- If a precipitate forms, filter the reaction mixture and wash the solid with water until the filtrate is neutral.
- Recrystallize the crude product from a minimum amount of boiling 95% ethanol.
- If no precipitate forms, extract the reaction mixture with dichloromethane.
- Wash the organic layer with water, dry over anhydrous sodium sulfate, and concentrate to obtain the crude product for further purification.

## Experimental Workflow

The following diagram illustrates the general workflow for performing an aqueous Wittig reaction.

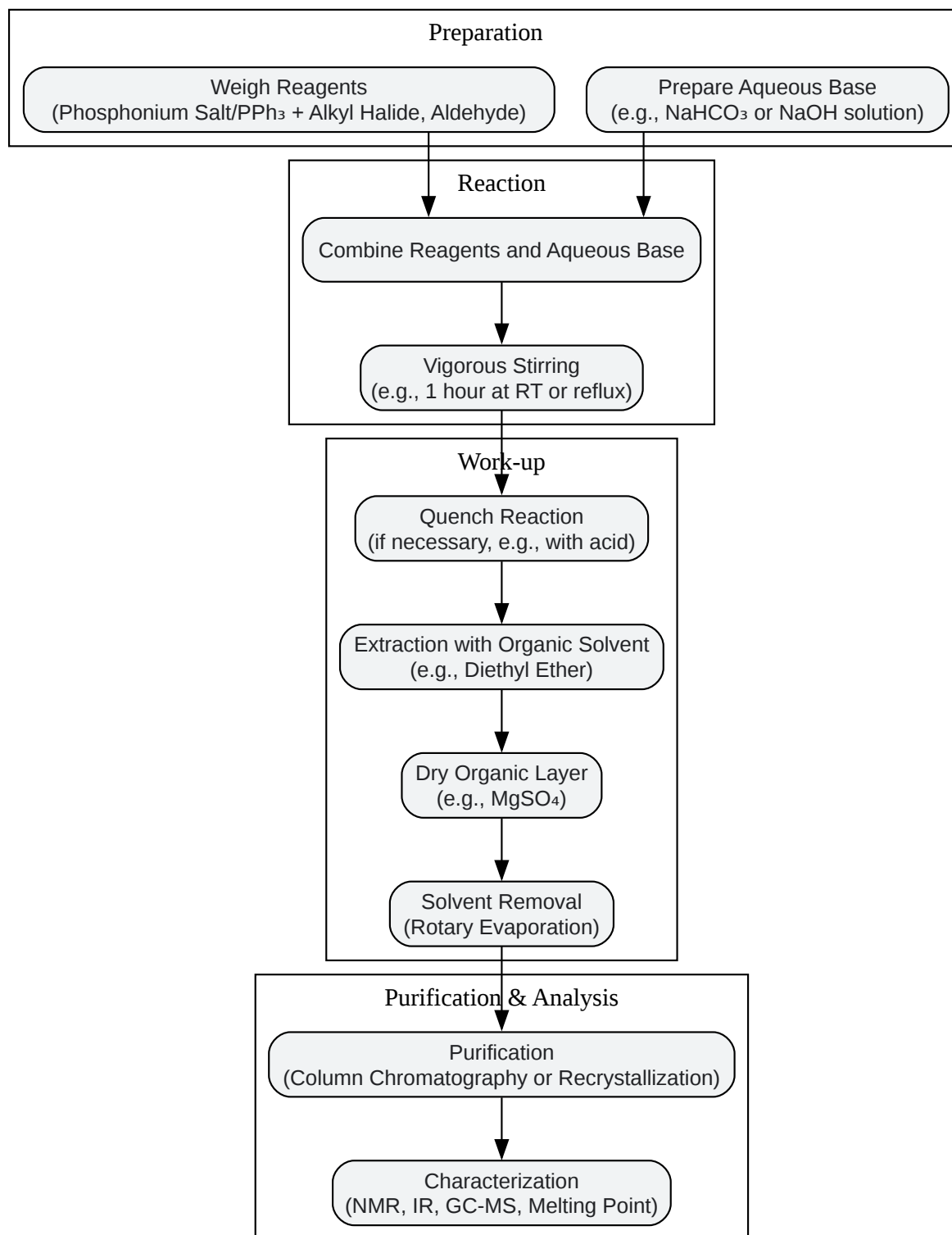

[Click to download full resolution via product page](#)

**Caption:** General experimental workflow for an aqueous Wittig reaction.

## Data Presentation

The following tables summarize representative quantitative data for the aqueous Wittig reaction under different conditions.

Table 1: One-Pot Aqueous Wittig Reaction with Various Aldehydes and Alkyl Halides using NaHCO<sub>3</sub>

Entry	Aldehyde (R <sup>1</sup> )	Alkyl Halide (R <sup>2</sup> )	% Yield <sup>a</sup>	E:Z Ratio <sup>b</sup>
1	Benzaldehyde	Methyl bromoacetate	46.5 (87.0) <sup>c</sup>	95.5:4.5
2	2-Thiophenecarboxaldehyde	Methyl bromoacetate	54.9 (87.0) <sup>c</sup>	99.8:0.2
3	Anisaldehyde	Methyl bromoacetate	55.8 (90.5) <sup>c</sup>	93.1:6.9
4	Benzaldehyde	Bromoacetonitrile	56.9 (86.1) <sup>c</sup>	58.8:41.2

<sup>a</sup> Isolated yield after column chromatography. <sup>b</sup> Determined by <sup>1</sup>H NMR spectroscopy. <sup>c</sup> Yield in parentheses is based on recovered starting material.

Table 2: Aqueous Wittig Reaction of Aromatic Aldehydes with Benzyltriphenylphosphonium Chloride using NaOH[1][2]

Aldehyde	Base/Conditions	Reaction Time	% Yield
Aromatic Aldehyde	10% NaOH, Reflux	2 hours	30
Aromatic Aldehyde	10% NaOH, Microwave	Not specified	40
Various Aromatic Aldehydes	NaOH	30 minutes	(Product formed)

## Applications in Drug Development

The aqueous Wittig reaction is a valuable tool in drug discovery and development for several reasons:

- **Green Chemistry:** Reduces the use of hazardous organic solvents, aligning with the principles of sustainable chemistry, which is increasingly important in the pharmaceutical industry.
- **Functional Group Tolerance:** The reaction conditions are often mild, allowing for the presence of various functional groups in the substrates, which is crucial when working with complex drug molecules.
- **Efficiency:** One-pot procedures and rapid reaction times can accelerate the synthesis of compound libraries for screening.
- **Scaffold Hopping and Analogue Synthesis:** Provides a straightforward method for modifying lead compounds by introducing double bonds, enabling the exploration of structure-activity relationships.

## Troubleshooting and Safety

- **Low Yields:** Ensure vigorous stirring to maximize the interfacial area between the aqueous and organic phases. The purity of the reagents, especially the aldehyde, is critical.
- **Side Reactions:** Aldehydes can be prone to oxidation or self-condensation. Using fresh, purified aldehydes can mitigate these issues.
- **Safety:** Always work in a well-ventilated fume hood. Wear appropriate personal protective equipment (PPE), including safety glasses, gloves, and a lab coat. Sodium hydroxide is corrosive and should be handled with care. Organic solvents are flammable.

### *Need Custom Synthesis?*

*BenchChem offers custom synthesis for rare earth carbides and specific isotopic labeling.*

*Email: [info@benchchem.com](mailto:info@benchchem.com) or [Request Quote Online](#).*

## References

- [1. scribd.com \[scribd.com\]](https://www.scribd.com)
- [2. libjournals.unca.edu \[libjournals.unca.edu\]](https://libjournals.unca.edu)
- To cite this document: BenchChem. [Application Notes and Protocols for Aqueous Wittig Reaction Using Triphenylphosphonium Chloride]. BenchChem, [2026]. [Online PDF]. Available at: [<https://www.benchchem.com/product/b1243017/docs#application-notes-and-protocols-for-aqueous-wittig-reaction-using-triphenylphosphonium-chloride>]

---

### Disclaimer & Data Validity:

The information provided in this document is for Research Use Only (RUO) and is strictly not intended for diagnostic or therapeutic procedures. While BenchChem strives to provide accurate protocols, we make no warranties, express or implied, regarding the fitness of this product for every specific experimental setup.

**Technical Support:** The protocols provided are for reference purposes. Unsure if this reagent suits your experiment?

**Need Industrial/Bulk Grade?** [Request Custom Synthesis Quote](#)

## BenchChem

Our mission is to be the trusted global source of essential and advanced chemicals, empowering scientists and researchers to drive progress in science and industry.

### Contact

Address: 3281 E Guasti Rd  
Ontario, CA 91761, United States  
Phone: (601) 213-4426  
Email: [info@benchchem.com](mailto:info@benchchem.com)

[Contact our Ph.D. Support Team for a compatibility check](#)

