

Technical Support Center: Improving the Selectivity of cIAP1-Targeting PROTACs

Author: BenchChem Technical Support Team. **Date:** April 2026

Compound of Interest

Compound Name: *cIAP1 Ligand-Linker Conjugates*
11
Cat. No.: B12429182

[Get Quote](#)

This technical support center provides troubleshooting guidance and frequently asked questions for researchers, scientists, and drug development professionals working on improving the selectivity of cellular inhibitor of apoptosis protein 1 (cIAP1)-targeting Proteolysis Targeting Chimeras (PROTACs).

Frequently Asked Questions (FAQs)

Q1: What are the main challenges in achieving selectivity for cIAP1-targeting PROTACs?

A1: The primary challenges in developing selective cIAP1-targeting PROTACs include:

- **High Homology with cIAP2:** cIAP1 and cIAP2 share high structural similarity, particularly in the BIR3 domain, which is often targeted by IAP antagonists used in PROTACs. This makes it difficult to achieve selective binding to cIAP1 without also engaging cIAP2.
- **Off-Target Effects:** The warhead of the PROTAC may bind to unintended proteins, leading to their degradation. Additionally, the E3 ligase-recruiting moiety can have its own off-target effects. For instance, some bestatin-derived components of cIAP-targeting molecules have shown off-target pharmacology[1].

- On-Target, Off-Tissue Toxicity: Even if a PROTAC is selective for cIAP1, widespread expression of cIAP1 in healthy tissues can lead to on-target toxicity in non-diseased cells.
- Ternary Complex Formation: The stability and conformation of the ternary complex (cIAP1-PROTAC-Target Protein) are critical for degradation efficiency and selectivity. A lack of positive cooperativity in forming this complex can lead to poor degradation.

Q2: My cIAP1-targeting PROTAC shows degradation of both cIAP1 and cIAP2. How can I improve selectivity for cIAP1?

A2: Improving selectivity for cIAP1 over cIAP2 is a common challenge. Here are some strategies:

- Linker Optimization: The length, rigidity, and attachment points of the linker are crucial for the geometry of the ternary complex. Systematically modifying the linker can identify a configuration that favors the formation of a productive cIAP1-PROTAC-target complex over a cIAP2-PROTAC-target complex[2][3].
- Warhead Modification: While many IAP antagonists are pan-IAP binders, subtle modifications to the warhead can exploit minor differences between the BIR3 domains of cIAP1 and cIAP2 to enhance selectivity.
- Exploiting Ternary Complex Cooperativity: Selectivity is not solely determined by binary binding affinity. Favorable protein-protein interactions between cIAP1 and the target protein within the ternary complex can drive selectivity, even with a non-selective warhead. Assays like Surface Plasmon Resonance (SPR) can be used to measure this cooperativity.
- Macrocyclization: Constraining the PROTAC's conformation through macrocyclization can pre-organize it into a bioactive conformation that favors binding to cIAP1, potentially enhancing selectivity[4].

Q3: I am observing the "hook effect" with my cIAP1-targeting PROTAC. What is it and how can I mitigate it?

A3: The "hook effect" is a phenomenon where the degradation efficiency of a PROTAC decreases at high concentrations. This occurs because at high concentrations, the PROTAC is

more likely to form binary complexes (PROTAC-cIAP1 or PROTAC-Target Protein) rather than the productive ternary complex required for degradation[5][6]. To mitigate the hook effect:

- **Dose-Response Experiments:** Perform a wide range of PROTAC concentrations in your degradation assays to identify the optimal concentration range and the onset of the hook effect.
- **Kinetic Studies:** Analyze the kinetics of ternary complex formation and dissociation. A PROTAC with a more stable and longer-lived ternary complex may be less prone to the hook effect.
- **Linker Design:** The linker can influence the stability of the ternary complex. A well-designed linker can promote cooperativity and reduce the likelihood of binary complex formation at high concentrations.

Q4: My PROTAC binds to cIAP1 and the target protein in binary assays, but I don't see any degradation in cells. What could be the problem?

A4: A lack of degradation despite binary binding can be due to several factors:

- **Poor Ternary Complex Formation:** The PROTAC may not be able to effectively bring cIAP1 and the target protein together in a productive orientation for ubiquitination.
- **Negative Cooperativity:** The binding of the PROTAC to one protein may hinder its binding to the other, leading to a destabilized ternary complex.
- **Cellular Permeability and Stability:** The PROTAC may have poor cell permeability or may be rapidly metabolized, preventing it from reaching sufficient intracellular concentrations.
- **Subcellular Localization:** The target protein and cIAP1 may be in different subcellular compartments, preventing the PROTAC from bringing them together[7].
- **Ubiquitination Sites:** The target protein may lack accessible lysine residues for ubiquitination.

Troubleshooting Guides

Issue 1: Inconsistent results in cIAP1 degradation assays (e.g., Western Blot).

Possible Cause	Troubleshooting Step
Cell passage number and confluency	Use cells within a consistent and low passage number range. Ensure consistent cell seeding density and confluency at the time of treatment.
PROTAC stability in media	Prepare fresh PROTAC solutions for each experiment. Assess the stability of your PROTAC in cell culture media over the time course of the experiment.
Antibody quality	Validate the specificity of your primary antibodies for cIAP1 and your loading control. Use a secondary antibody from a reputable source.
Loading and transfer variability	Ensure accurate protein quantification before loading. Use a reliable loading control and verify consistent transfer efficiency across the membrane.

Issue 2: High off-target degradation observed in proteomics studies.

Possible Cause	Troubleshooting Step
Promiscuous warhead	Characterize the binding profile of your warhead against a panel of related and unrelated proteins. Consider redesigning the warhead for improved selectivity.
Linker-induced off-targets	Synthesize and test PROTACs with different linker compositions and lengths to assess their impact on the off-target profile.
Intrinsic activity of the E3 ligase ligand	Test a control molecule consisting of the E3 ligase ligand and linker to identify off-targets of this moiety.
Formation of non-productive ternary complexes	Use biophysical assays like SPR or FP to study the formation and stability of ternary complexes with potential off-target proteins.

Quantitative Data Summary

Table 1: Binding Affinities and Selectivity of SMAC Mimetics for IAP Proteins

Compound	XIAP BIR3 Ki (nM)	cIAP1 BIR3 Ki (nM)	cIAP2 BIR3 Ki (nM)	Selectivity (cIAP1 vs XIAP)	Reference
1	156	2.5	4.5	63-fold	[8]
3	392	1.8	4.9	218-fold	[8]
4	870	1.1	3.0	791-fold	[8]
5	3080	3.2	9.5	962-fold	[8]

Table 2: Degradation Potency of a BTK-targeting cIAP1 PROTAC

Compound	DC50 in THP-1 cells (nM)	Reference
SNIPER-12	182 ± 57	[9]

Experimental Protocols & Methodologies

1. Fluorescence Polarization (FP) Assay for Ternary Complex Formation

This assay measures the binding of a fluorescently labeled ligand to a protein. For PROTACs, it can be adapted to assess ternary complex formation.

- Principle: A fluorescently labeled peptide derived from a known cIAP1-binding protein (e.g., SMAC) is used. In its free form, the peptide tumbles rapidly, resulting in low fluorescence polarization. When bound to cIAP1, its tumbling is slowed, increasing the polarization. A PROTAC's ability to bind cIAP1 can be measured by its displacement of the fluorescent peptide. To assess ternary complex formation, the assay is performed in the presence of the target protein.
- Methodology:
 - A constant concentration of cIAP1 BIR3 domain and a fluorescently labeled SMAC-derived peptide are incubated to form a binary complex with a high FP signal.
 - Increasing concentrations of the PROTAC are added to compete with the fluorescent peptide for binding to cIAP1, leading to a decrease in FP signal.
 - To measure ternary complex formation, the experiment is repeated with the addition of a saturating concentration of the target protein. A shift in the IC50 value in the presence of the target protein indicates the formation of a ternary complex and can be used to calculate the cooperativity.

2. Surface Plasmon Resonance (SPR) for Binding Kinetics

SPR is a label-free technique that provides real-time kinetic data on biomolecular interactions.

- Principle: One of the binding partners (e.g., cIAP1) is immobilized on a sensor chip. A solution containing the other binding partners (PROTAC and target protein) is flowed over the surface. The binding events cause a change in the refractive index at the sensor surface, which is detected as a response unit (RU).
- Methodology:

- Immobilize biotinylated cIAP1 on a streptavidin-coated sensor chip.
- To measure binary binding, flow a solution containing the PROTAC over the chip and measure the association and dissociation rates.
- To measure ternary complex formation, pre-incubate the PROTAC with a near-saturating concentration of the target protein and flow this mixture over the cIAP1-coated chip[10][11].
- The kinetic parameters (k_{on} , k_{off}) and affinity (KD) of the ternary complex can be determined from the resulting sensorgram.

3. Cellular Thermal Shift Assay (CETSA) for Target Engagement

CETSA assesses the target engagement of a compound in a cellular environment by measuring changes in the thermal stability of the target protein.

- Principle: Ligand binding can stabilize a protein, making it more resistant to thermal denaturation. In CETSA, cells are treated with the PROTAC, heated, and the amount of soluble target protein remaining is quantified.
- Methodology:
 - Treat cells with the PROTAC at various concentrations.
 - Heat the cells at a range of temperatures.
 - Lyse the cells and separate the soluble fraction from the precipitated proteins by centrifugation.
 - Quantify the amount of soluble cIAP1 and the target protein in the supernatant by Western blot or mass spectrometry[12][13]. An increase in the melting temperature of the target protein indicates target engagement by the PROTAC.

4. NanoBRET™ Assay for Intracellular Degradation

NanoBRET™ (Bioluminescence Resonance Energy Transfer) is a live-cell assay that can be used to monitor protein degradation in real-time.

- Principle: The target protein is endogenously tagged with a NanoLuc® luciferase (the donor), and a fluorescently labeled tracer that binds to the target is added to the cells. When the tracer binds to the NanoLuc®-tagged protein, BRET occurs. A PROTAC that degrades the target protein will cause a loss of the BRET signal.
- Methodology:
 - Use CRISPR/Cas9 to endogenously tag the target protein with NanoLuc® luciferase in your cell line of interest.
 - Add a cell-permeable fluorescent tracer that binds to the target protein.
 - Treat the cells with the cIAP1-targeting PROTAC.
 - Measure the BRET signal over time. A decrease in the BRET signal indicates degradation of the target protein.

Visualizations

Signaling Pathway: cIAP1-Mediated Regulation of NF- κ B

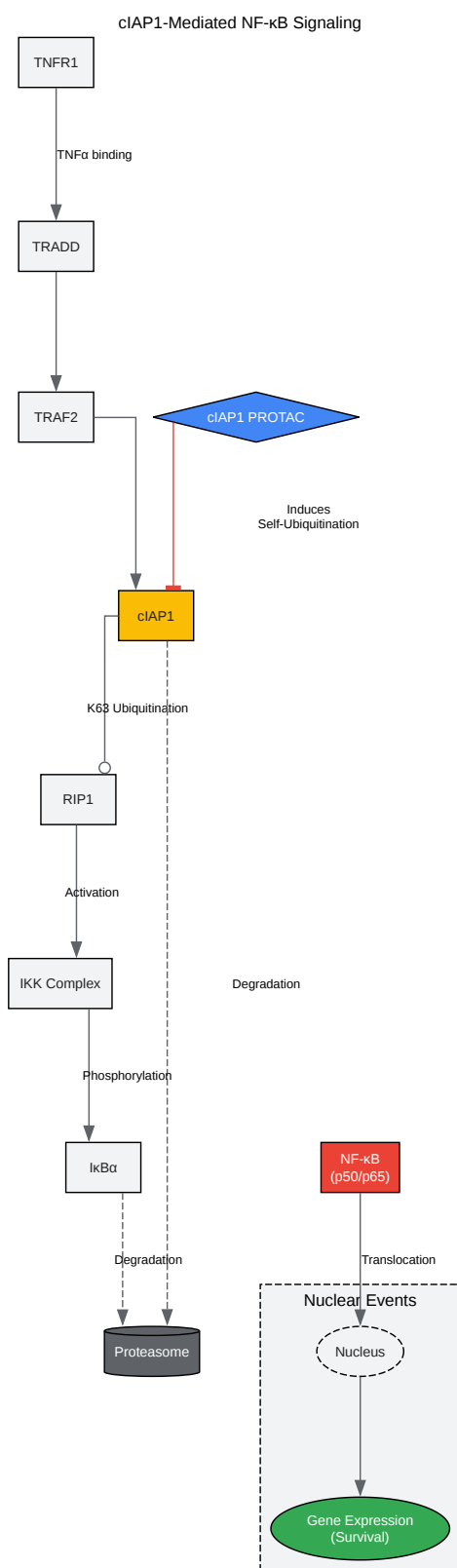

[Click to download full resolution via product page](#)

Caption: cIAP1's role in the canonical NF-κB pathway and its degradation by a PROTAC.

Experimental Workflow: SPR-Based Ternary Complex Analysis

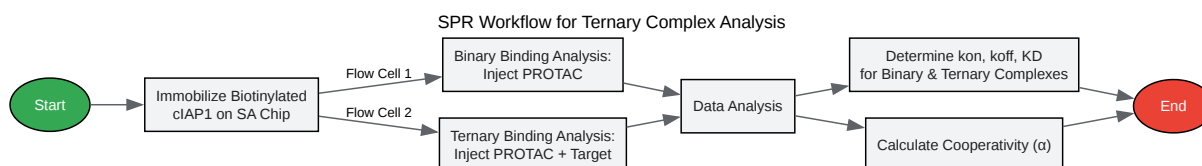

[Click to download full resolution via product page](#)

Caption: Workflow for assessing PROTAC-induced ternary complex formation using SPR.

Logical Diagram: Troubleshooting PROTAC Inefficacy

Troubleshooting Ineffective PROTAC Degradation

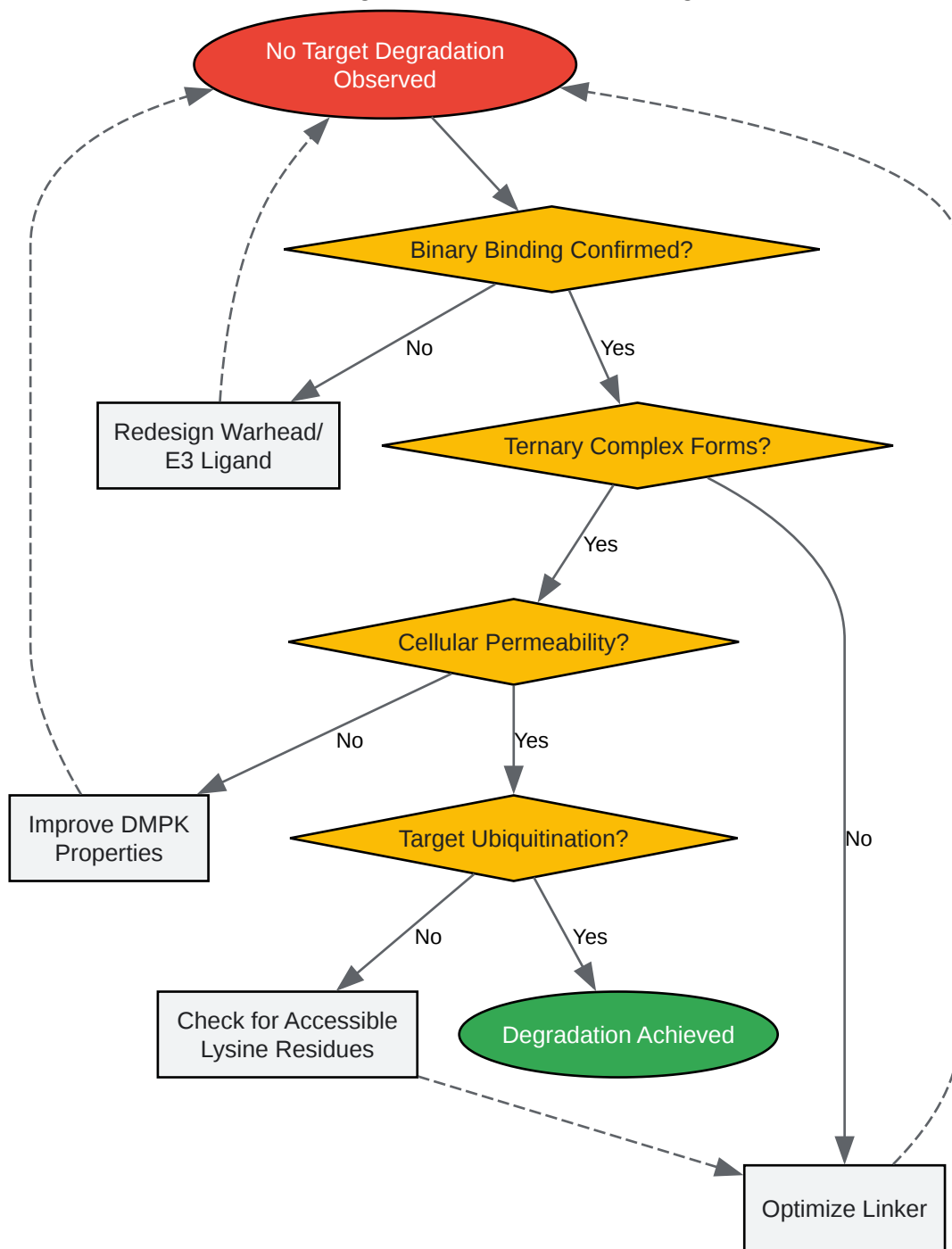

[Click to download full resolution via product page](#)

Caption: A logical guide to troubleshooting a cIAP1-targeting PROTAC that fails to degrade its target.

Need Custom Synthesis?

BenchChem offers custom synthesis for rare earth carbides and specific isotopic labeling.

Email: info@benchchem.com or [Request Quote Online](#).

References

- 1. A critical evaluation of the approaches to targeted protein degradation for drug discovery - PMC [[pmc.ncbi.nlm.nih.gov](https://pubmed.ncbi.nlm.nih.gov/)]
- 2. PROTACs improve selectivity for targeted proteins – ScienceOpen [[scienceopen.com](https://www.scienceopen.com/)]
- 3. Novel approaches for the rational design of PROTAC linkers [[explorationpub.com](https://www.explorationpub.com/)]
- 4. [researchgate.net](https://www.researchgate.net/) [[researchgate.net](https://www.researchgate.net/)]
- 5. Novel Design Strategies to Enhance the Efficiency of Proteolysis Targeting Chimeras - PMC [[pmc.ncbi.nlm.nih.gov](https://pubmed.ncbi.nlm.nih.gov/)]
- 6. From Conception to Development: Investigating PROTACs Features for Improved Cell Permeability and Successful Protein Degradation - PMC [[pmc.ncbi.nlm.nih.gov](https://pubmed.ncbi.nlm.nih.gov/)]
- 7. [researchgate.net](https://www.researchgate.net/) [[researchgate.net](https://www.researchgate.net/)]
- 8. Potent and Selective Small-Molecule Inhibitors of cIAP1/2 Proteins Reveal That the Binding of Smac Mimetics to XIAP BIR3 Is Not Required for Their Effective Induction of Cell Death in Tumor Cells - PMC [[pmc.ncbi.nlm.nih.gov](https://pubmed.ncbi.nlm.nih.gov/)]
- 9. Recent advances in IAP-based PROTACs (SNIPERs) as potential therapeutic agents - PMC [[pmc.ncbi.nlm.nih.gov](https://pubmed.ncbi.nlm.nih.gov/)]
- 10. SPR-Measured Dissociation Kinetics of PROTAC Ternary Complexes Influence Target Degradation Rate - PMC [[pmc.ncbi.nlm.nih.gov](https://pubmed.ncbi.nlm.nih.gov/)]
- 11. [researchgate.net](https://www.researchgate.net/) [[researchgate.net](https://www.researchgate.net/)]
- 12. [pelagobio.com](https://www.pelagobio.com/) [[pelagobio.com](https://www.pelagobio.com/)]
- 13. A Shift in Thinking: Cellular Thermal Shift Assay-Enabled Drug Discovery - PMC [[pmc.ncbi.nlm.nih.gov](https://pubmed.ncbi.nlm.nih.gov/)]
- To cite this document: BenchChem. [Technical Support Center: Improving the Selectivity of cIAP1-Targeting PROTACs]. BenchChem, [2026]. [Online PDF]. Available at: [<https://www.benchchem.com/product/b12429182/docs#technical-support-center-improving-the-selectivity-of-ciap1-targeting-protacs>]

Disclaimer & Data Validity:

The information provided in this document is for Research Use Only (RUO) and is strictly not intended for diagnostic or therapeutic procedures. While BenchChem strives to provide accurate protocols, we make no warranties, express or implied, regarding the fitness of this product for every specific experimental setup.

Technical Support: The protocols provided are for reference purposes. Unsure if this reagent suits your experiment?

Need Industrial/Bulk Grade? [Request Custom Synthesis Quote](#)

BenchChem

Our mission is to be the trusted global source of essential and advanced chemicals, empowering scientists and researchers to drive progress in science and industry.

Contact

Address: 3281 E Guasti Rd
Ontario, CA 91761, United States
Phone: (601) 213-4426
Email: info@benchchem.com

[Contact our Ph.D. Support Team for a compatibility check](#)