

Assessing the Selectivity Profile of a cIAP1 Degradator: A Comparative Guide

Author: BenchChem Technical Support Team. **Date:** April 2026

Compound of Interest

Compound Name: *cIAP1 Ligand-Linker Conjugates*
11
Cat. No.: B12429182

[Get Quote](#)

For Researchers, Scientists, and Drug Development Professionals

Cellular Inhibitor of Apoptosis Protein 1 (cIAP1) has emerged as a compelling therapeutic target in oncology and inflammatory diseases due to its critical role in regulating apoptosis and NF- κ B signaling.^{[1][2][3][4][5][6]} Targeted degradation of cIAP1 using heterobifunctional degraders, such as Proteolysis Targeting Chimeras (PROTACs) and Specific and Non-genetic IAP-dependent Protein Erasers (SNIPERs), offers a promising therapeutic strategy. However, ensuring the selective degradation of cIAP1 with minimal off-target effects is paramount for developing safe and effective therapeutics.

This guide provides a framework for assessing the selectivity profile of a novel cIAP1 degrader. It outlines key experimental approaches, presents data in a comparative format, and provides detailed protocols for essential assays.

Data Presentation: Comparative Selectivity Profile of a cIAP1 Degradator

To objectively evaluate the selectivity of a novel cIAP1 degrader, it is crucial to compare its degradation profile against a known, well-characterized cIAP1-targeting molecule and a negative control. The following tables present a template with hypothetical data for a fictional cIAP1 degrader, "Degrader X," compared to the known IAP antagonist LCL161 and an inactive epimer control.

Table 1: On-Target and Key Off-Target Degradation

This table summarizes the degradation of the intended target (cIAP1) and other closely related IAP family members. Data is presented as the percentage of protein remaining after treatment, with lower percentages indicating more effective degradation.

Compound	Concentration (µM)	cIAP1 (% remaining)	cIAP2 (% remaining)	XIAP (% remaining)
Degrader X	0.1	15	45	95
1	5	20	90	
LCL161	0.1	25	30	85
1	10	15	80	
Inactive Control	1	98	97	99

Table 2: Global Proteomics Selectivity Profile

This table provides a broader view of selectivity by highlighting the number of significantly degraded proteins identified through quantitative proteomics. A highly selective degrader will affect a minimal number of off-target proteins.

Compound (1 μ M)	Total Proteins Quantified	Significantly Degraded Proteins (Fold Change < 0.5, p < 0.05)	Top 5 Off-Target Proteins Degraded
Degrader X	>8000	8	Protein A, Protein B, Protein C, Protein D, Protein E
LCL161	>8000	15	Protein F, Protein G, Protein H, Protein I, Protein J
Inactive Control	>8000	1	-

Mandatory Visualizations

To facilitate a deeper understanding of the biological context and experimental design, the following diagrams are provided.

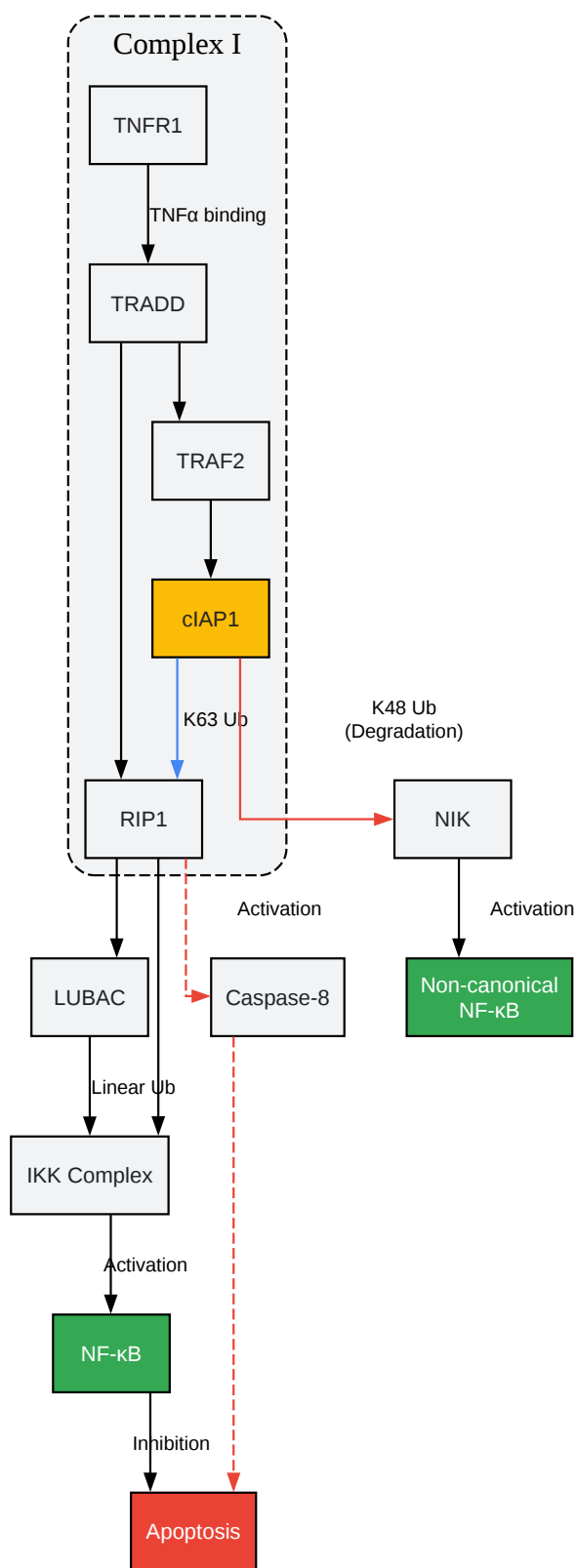

[Click to download full resolution via product page](#)

cIAP1 Signaling Pathway

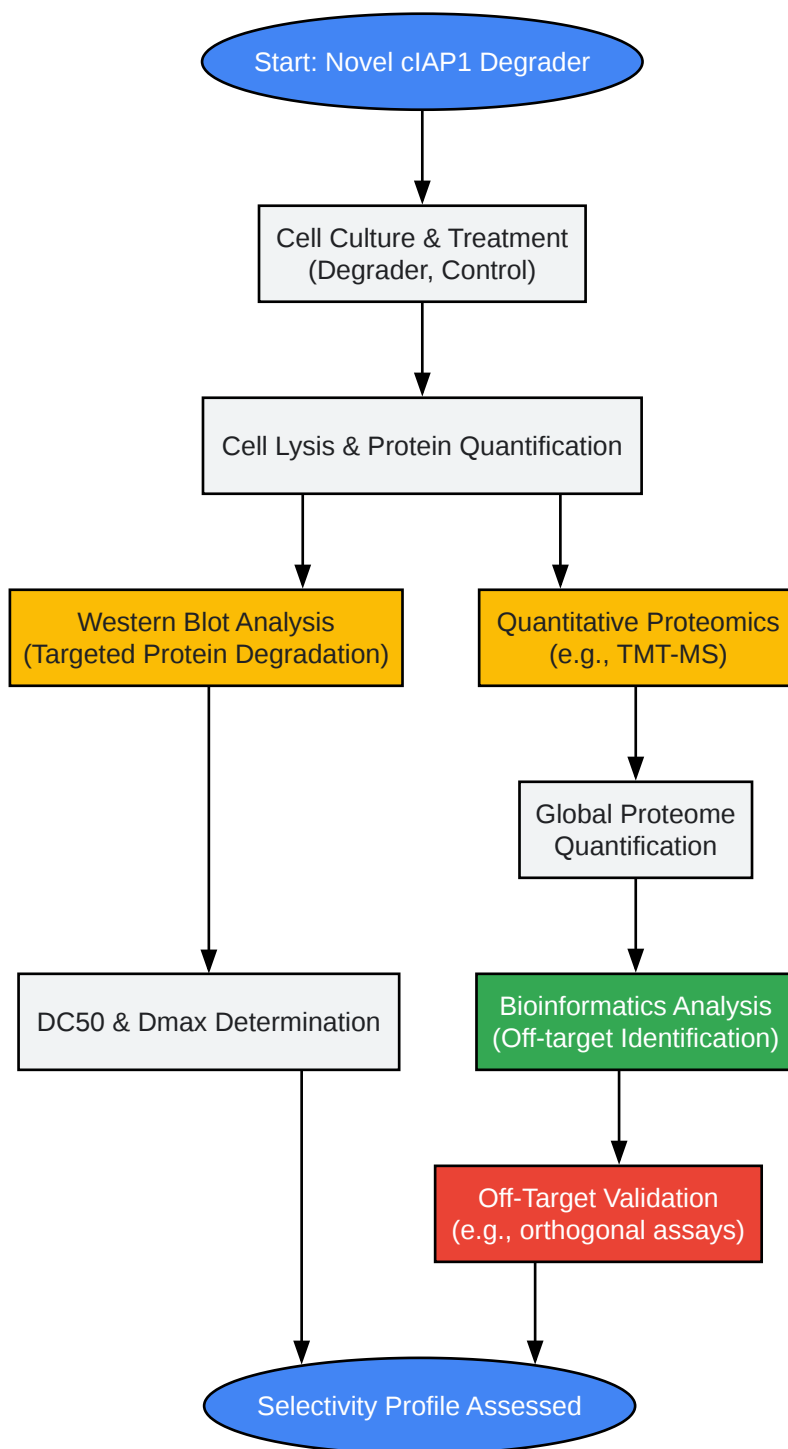

[Click to download full resolution via product page](#)

Experimental Workflow for Selectivity Assessment

Experimental Protocols

Detailed and reproducible protocols are essential for accurate assessment of a degrader's selectivity profile.

Western Blot for Targeted Protein Degradation

This protocol is used to quantify the degradation of specific proteins of interest.

a. Cell Culture and Treatment:

- Seed cells (e.g., a relevant cancer cell line) in 6-well plates and allow them to attach overnight.
- Treat cells with the cIAP1 degrader at a range of concentrations (e.g., 0.01 to 10 μ M) for various time points (e.g., 2, 4, 8, 24 hours).
- Include a vehicle control (e.g., DMSO) and a positive control (e.g., LCL161).

b. Cell Lysis:

- Wash cells twice with ice-cold phosphate-buffered saline (PBS).
- Lyse the cells in radioimmunoprecipitation assay (RIPA) buffer supplemented with protease and phosphatase inhibitors.
- Scrape the cells, collect the lysate, and incubate on ice for 30 minutes.
- Clarify the lysate by centrifugation at 14,000 x g for 15 minutes at 4°C.

c. Protein Quantification:

- Determine the protein concentration of each lysate using a BCA protein assay.

d. SDS-PAGE and Immunoblotting:

- Normalize protein concentrations and prepare samples with Laemmli sample buffer.
- Separate proteins by sodium dodecyl sulfate-polyacrylamide gel electrophoresis (SDS-PAGE).

- Transfer the separated proteins to a polyvinylidene difluoride (PVDF) membrane.
- Block the membrane with 5% non-fat dry milk or bovine serum albumin (BSA) in Tris-buffered saline with 0.1% Tween-20 (TBST) for 1 hour at room temperature.
- Incubate the membrane with primary antibodies against cIAP1, cIAP2, XIAP, and a loading control (e.g., GAPDH or β -actin) overnight at 4°C.
- Wash the membrane three times with TBST.
- Incubate with a horseradish peroxidase (HRP)-conjugated secondary antibody for 1 hour at room temperature.
- Wash the membrane again three times with TBST.
- Visualize the protein bands using an enhanced chemiluminescence (ECL) substrate and an imaging system.

e. Data Analysis:

- Quantify the band intensities using image analysis software.
- Normalize the target protein band intensity to the loading control.
- Calculate the percentage of protein remaining relative to the vehicle-treated control.
- Plot the percentage of remaining protein against the degrader concentration to determine the DC50 (half-maximal degradation concentration) and Dmax (maximum degradation).

Quantitative Proteomics for Global Selectivity Profiling

This protocol outlines a Tandem Mass Tag (TMT)-based quantitative proteomics experiment to assess the global selectivity of the degrader.

a. Sample Preparation:

- Culture and treat cells with the cIAP1 degrader at a fixed concentration (e.g., 1 μ M) and a specific time point, including vehicle and control compounds. Use biological triplicates for

each condition.

- Lyse cells in a urea-based lysis buffer compatible with mass spectrometry.
- Quantify protein concentration using a BCA assay.

b. Protein Digestion and TMT Labeling:

- Take an equal amount of protein from each sample (e.g., 50-100 µg).
- Reduce disulfide bonds with dithiothreitol (DTT) and alkylate cysteine residues with iodoacetamide.
- Digest the proteins into peptides using trypsin overnight at 37°C.
- Label the peptides from each condition with a unique TMT isobaric tag according to the manufacturer's instructions.
- Combine the labeled peptide samples.

c. Mass Spectrometry Analysis:

- Fractionate the combined, labeled peptide mixture using high-pH reversed-phase liquid chromatography.
- Analyze each fraction by liquid chromatography-tandem mass spectrometry (LC-MS/MS) on a high-resolution mass spectrometer.

d. Data Analysis:

- Process the raw mass spectrometry data using a suitable software package (e.g., MaxQuant, Proteome Discoverer).
- Identify peptides and proteins by searching the data against a human protein database.
- Quantify the relative abundance of proteins based on the reporter ion intensities from the TMT tags.

- Perform statistical analysis to identify proteins that are significantly up- or down-regulated upon treatment with the cIAP1 degrader. A common threshold for significant degradation is a fold change of less than 0.5 and a p-value less than 0.05.
- Visualize the data using volcano plots to highlight significantly degraded proteins.

Conclusion

A thorough assessment of the selectivity profile is a critical step in the development of any cIAP1 degrader. By employing a combination of targeted and global proteomic approaches, researchers can gain a comprehensive understanding of a degrader's on-target potency and off-target liabilities. The methodologies and data presentation formats outlined in this guide provide a robust framework for these essential studies, ultimately facilitating the development of safer and more effective targeted protein degradation therapies.

Need Custom Synthesis?

BenchChem offers custom synthesis for rare earth carbides and specific isotopic labeling.

Email: info@benchchem.com or [Request Quote Online](#).

References

- [1. researchgate.net \[researchgate.net\]](#)
- [2. pnas.org \[pnas.org\]](#)
- [3. The tumor necrosis factor receptor 2 signal transducers TRAF2 and c-IAP1 are components of the tumor necrosis factor receptor 1 signaling complex - PMC \[pmc.ncbi.nlm.nih.gov\]](#)
- [4. Roles of c-IAP proteins in TNF receptor family activation of NF-κB signaling - PubMed \[pubmed.ncbi.nlm.nih.gov\]](#)
- [5. aacrjournals.org \[aacrjournals.org\]](#)
- [6. lcms.labrulez.com \[lcms.labrulez.com\]](#)
- To cite this document: BenchChem. [Assessing the Selectivity Profile of a cIAP1 Degradation: A Comparative Guide]. BenchChem, [2026]. [Online PDF]. Available at: [\[https://www.benchchem.com/product/b12429182/docs#assessing-the-selectivity-profile-of-a-ciap1-degrader-a-comparative-guide\]](https://www.benchchem.com/product/b12429182/docs#assessing-the-selectivity-profile-of-a-ciap1-degrader-a-comparative-guide)

Disclaimer & Data Validity:

The information provided in this document is for Research Use Only (RUO) and is strictly not intended for diagnostic or therapeutic procedures. While BenchChem strives to provide accurate protocols, we make no warranties, express or implied, regarding the fitness of this product for every specific experimental setup.

Technical Support: The protocols provided are for reference purposes. Unsure if this reagent suits your experiment?

Need Industrial/Bulk Grade? [Request Custom Synthesis Quote](#)

BenchChem

Our mission is to be the trusted global source of essential and advanced chemicals, empowering scientists and researchers to drive progress in science and industry.

Contact

Address: 3281 E Guasti Rd
Ontario, CA 91761, United States
Phone: (601) 213-4426
Email: info@benchchem.com

[Contact our Ph.D. Support Team for a compatibility check](#)