

# Isotopic Labeling of Curcumin: A Technical Guide for Metabolic & Mechanistic Research

**Author:** BenchChem Technical Support Team. **Date:** April 2026

## Compound of Interest

Compound Name: Tetrahydro Curcumin-d6

Cat. No.: B12425775

[Get Quote](#)

## Executive Summary

Curcumin (diferuloylmethane) is a pharmacologically potent but metabolically unstable polyphenol. Its clinical translation is frequently hindered by rapid systemic elimination and poor bioavailability.<sup>[1]</sup> For researchers, the challenge lies not just in delivery, but in detection: distinguishing the parent molecule from its rapid cascade of reductive metabolites (e.g., tetrahydrocurcumin) and conjugates (glucuronides/sulfates).

Isotopic labeling—specifically with Deuterium (

H), Carbon-13 (

C), and Carbon-14 (

C)—provides the only definitive method to track these pathways with molecular specificity. This guide outlines the strategic rationale, synthetic protocols, and analytical validation necessary to deploy isotopically labeled curcumin in high-impact research.

## Strategic Rationale: Selecting the Right Isotope

Before synthesis, the research objective must dictate the isotope and labeling position.

Application	Recommended Isotope	Label Position	Rationale
Metabolic Stability (PK)	Deuterium (H)	Phenolic -OH, Methine Bridge	Kinetic Isotope Effect (KIE): C-D bonds are stronger than C-H bonds, potentially slowing enzymatic degradation (e.g., by CYP450s) without altering binding affinity.[2]
Metabolite Identification	Carbon-13 (C)	Acetylacetone Chain (C3, C4, C5)	Mass Shift: Creates a unique mass signature ( ) in LC-MS/MS, allowing differentiation of endogenous interferences from drug-derived metabolites.[2]
Biosynthetic Tracking	Carbon-13 (C)	Ring Carbons	NMR Resolution: Allows tracking of precursor incorporation (e.g., phenylalanine) into the curcuminoid scaffold via C-NMR.[2]
ADME / Mass Balance	Carbon-14 (C)	Methoxy Groups	Radiometric Detection: Essential for quantitative whole-body autoradiography (QWBA) to determine

total excretion and  
tissue distribution.[2]

---

## Synthetic Strategies & Protocols

The Pabon Reaction is the industry-standard method for synthesizing curcuminoids.[2] It utilizes a boron-complex protection strategy to prevent Knoevenagel condensation at the wrong position, ensuring the formation of the 1,7-diarylheptanoid skeleton.

### Core Workflow: The Pabon Method (Modified for Micro-Scale Labeling)

This protocol is adaptable for both

C and

H labeling by substituting the starting materials:

- For Chain Labeling: Use

acetylacetone.

- For Ring/Methoxy Labeling: Use

vanillin or

vanillin.[2]

#### Reagents:

- Precursor A: Acetylacetone (or labeled variant)[3]
- Precursor B: Vanillin (or labeled variant)
- Complexing Agent: Boric oxide ( ) or Tributyl borate
- Catalyst:

-Butylamine[2]

- Solvent: Ethyl Acetate (anhydrous)

## Step-by-Step Protocol:

- Boron Complex Formation (The "Paste" Step):
  - Dissolve Acetylacetone (1.0 eq) and  
  
(0.7 eq) in Ethyl Acetate.
  - Heat to 80°C for 30 minutes. The mixture will thicken as the boron-acetylacetone complex forms.
  - Technical Insight: This step is critical. The boron protects the C3/C5 carbonyls, forcing the subsequent reaction to occur at the terminal methyl groups of the acetylacetone, preventing side reactions.
- Condensation:
  - Add Vanillin (2.0 eq) and Tributyl borate (2.0 eq) to the complex.
  - Add  
  
-Butylamine (0.2 eq) dropwise as a catalyst.[2]
  - Stir at 80°C for 4 hours. The solution will turn a deep red-brown, indicating the formation of the rosocyanine-like intermediate.
- Hydrolysis & Workup:
  - Add 0.4 M HCl (aqueous) and stir at 60°C for 1 hour. This breaks the boron complex, releasing the free curcumin.
  - Extract with Ethyl Acetate (  
  
).[4] Wash organic layer with brine and water.
  - Dry over

and concentrate in vacuo.

- Purification:
  - Recrystallize from Methanol/Water or purify via Flash Chromatography (DCM:MeOH 98:2).
  - Target Yield: 25–40% (typical for labeled synthesis).

## Visualization of Synthetic & Metabolic Pathways

The following diagram illustrates the Pabon synthesis pathway and the subsequent metabolic reduction of curcumin, highlighting where the isotopic labels are retained.

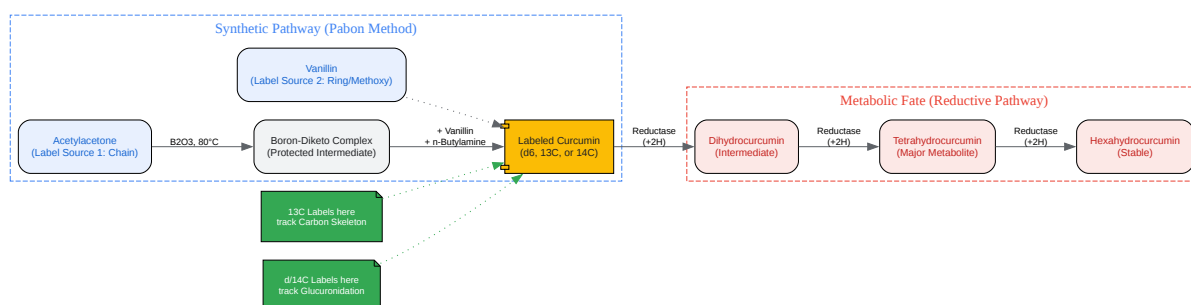

[Click to download full resolution via product page](#)

Caption: Synthesis of labeled curcumin via Pabon method and subsequent reductive metabolism tracking.

## Analytical Validation

A labeled compound is useless without rigorous validation. Self-validating protocols must include:

## A. Isotopic Enrichment Calculation (MS)

For a

C-labeled batch, calculate the Isotopic Enrichment (IE) using LC-MS.

Requirement:

enrichment is standard for quantitative metabolic studies to avoid data skewing from the "unlabeled" background.

## B. NMR Confirmation ( H and C )

- H-NMR (Deuterium Labeling): Verify the disappearance of specific proton signals.
  - Example: For  
  
-curcumin (methoxy labeling), the strong singlet at  
  
ppm (methoxy protons) should vanish.
- C-NMR (Carbon Labeling): Verify the enhancement of specific carbon signals.
  - Example: For  
  
-curcumin, the carbonyl carbons (  
  
ppm) will show massive signal enhancement and potential coupling splitting (  
  
) if adjacent carbons are also labeled.

## C. Purity Check (HPLC)

Curcumin exists in equilibrium with its keto-enol tautomers.[2]

- Column: C18 Reverse Phase (e.g., Agilent Zorbax SB-C18).[2]
- Mobile Phase: Acetonitrile : Water (0.1% Formic Acid) gradient (40%

90% ACN).

- Detection: 420 nm (Curcumin max) and 280 nm (degradation products like vanillin).

## Technical Nuances & Troubleshooting

### The "Scrambling" Issue

- Problem: Protons on the phenolic -OH and the central enolic position (C4) are exchangeable in protic solvents (Methanol, Water).
- Implication: You cannot use deuterium labeling at these positions for long-term storage or metabolic tracking in aqueous media, as the deuterium will swap with solvent hydrogen (H).
- Solution: For metabolic stability studies, use Carbon-13 at the skeleton or Deuterium on the non-exchangeable carbon backbone (e.g., the aromatic ring or the methoxy methyl group).

### Stability in Solution

Labeled curcumin degrades rapidly in alkaline buffers (pH > 7.4) via autoxidation.

- Protocol: Always prepare stock solutions in DMSO-d6 or slightly acidic buffers (pH 6.0) to maintain the integrity of the labeled standard during experiments.

### References

- Facile synthesis of deuterated and [14C]labeled analogues of vanillin and curcumin.
  - Source: National Institutes of Health (PMC) / J Labelled Comp Radiopharm.
  - Context: Describes the Pabon method modifications for radiolabeling and yields (25-27%).
  - URL:[\[Link\]](#)
- The biosynthetic pathway of curcuminoid in turmeric (*Curcuma longa*) as revealed by 13C-labeled precursors.

- Source: Bioscience, Biotechnology, and Biochemistry.
- Context: Demonstrates the use of  $^{13}\text{C}$ -NMR to track phenylalanine incorporation.
- URL:[\[Link\]](#)
- Synthesis and Semi-synthesis of Curcumin as a Medical Precursor.
  - Source: Journal of Medicinal and Chemical Sciences.
  - Context: Validation of synthetic curcumin against natural curcumin.
  - URL:[\[Link\]](#)
- Increasing metabolic stability via the deuterium kinetic isotope effect.
  - Source: Bioorganic & Medicinal Chemistry Letters.[\[5\]](#)
  - Context: General principles of KIE applied to drug stability, relevant for designing deuterated drugs.
  - URL:[\[Link\]](#)
- Stable isotope labeling strategy for curcumin metabolite study in human liver microsomes.
  - Source: Journal of the American Society for Mass Spectrometry.
  - Context: Using  $^{18}\text{O}$  labeling and MS to identify glucuronide conjugates.
  - URL:[\[Link\]](#)

#### Need Custom Synthesis?

BenchChem offers custom synthesis for rare earth carbides and specific isotopic labeling.

Email: [info@benchchem.com](mailto:info@benchchem.com) or [Request Quote Online](#).

## Sources

- [1. Frontiers | Curcumin: biochemistry, pharmacology, advanced drug delivery systems, and its epigenetic role in combating cancer \[frontiersin.org\]](#)
- [2. 1,7-bis\(4-Hydroxy-3-methoxyphenyl\)heptane-3,5-dione \[webbook.nist.gov\]](#)
- [3. researchgate.net \[researchgate.net\]](#)

- [4. researchgate.net \[researchgate.net\]](#)
- [5. Increasing metabolic stability via the deuterium kinetic isotope effect: An example from a proline-amide-urea aminothiazole series of phosphatidylinositol-3 kinase alpha inhibitors - PubMed \[pubmed.ncbi.nlm.nih.gov\]](#)
- To cite this document: BenchChem. [Isotopic Labeling of Curcumin: A Technical Guide for Metabolic & Mechanistic Research]. BenchChem, [2026]. [Online PDF]. Available at: [\[https://www.benchchem.com/product/b12425775/docs#isotopic-labeling-of-curcumin-a-technical-guide-for-metabolic-mechanistic-research\]](https://www.benchchem.com/product/b12425775/docs#isotopic-labeling-of-curcumin-a-technical-guide-for-metabolic-mechanistic-research)

---

### Disclaimer & Data Validity:

The information provided in this document is for Research Use Only (RUO) and is strictly not intended for diagnostic or therapeutic procedures. While BenchChem strives to provide accurate protocols, we make no warranties, express or implied, regarding the fitness of this product for every specific experimental setup.

**Technical Support:** The protocols provided are for reference purposes. Unsure if this reagent suits your experiment?

**Need Industrial/Bulk Grade?** [Request Custom Synthesis Quote](#)

## BenchChem

Our mission is to be the trusted global source of essential and advanced chemicals, empowering scientists and researchers to drive progress in science and industry.

### Contact

Address: 3281 E Guasti Rd  
Ontario, CA 91761, United States  
Phone: (601) 213-4426  
Email: [info@benchchem.com](mailto:info@benchchem.com)

[Contact our Ph.D. Support Team for a compatibility check](#)

