

# Interpreting inconsistent results in AS2521780 experiments

**Author:** BenchChem Technical Support Team. **Date:** April 2026

## Compound of Interest

Compound Name: AS2521780

Cat. No.: B12425242

[Get Quote](#)

## Technical Support Center: AS2521780 Experiments

This technical support center provides troubleshooting guidance and answers to frequently asked questions for researchers using **AS2521780**, a potent and selective inhibitor of Protein Kinase C theta (PKC $\theta$ ). Our goal is to help you interpret inconsistent results and optimize your experimental outcomes.

### Frequently Asked Questions (FAQs)

Q1: What is **AS2521780** and what is its primary mechanism of action?

**AS2521780** is a novel, potent, and highly selective small molecule inhibitor of Protein Kinase C theta (PKC $\theta$ )[1][2][3]. Its primary mechanism of action is the inhibition of T-cell activation and proliferation by blocking the signaling pathways downstream of the T-cell receptor (TCR)[4][5][6]. Specifically, it has been shown to suppress the transcription of Interleukin-2 (IL-2), a key cytokine in T-cell proliferation[1][2][3][4].

Q2: What are the reported IC50 values for **AS2521780**?

The half-maximal inhibitory concentration (IC50) values for **AS2521780** can vary depending on the experimental system. Key reported values are summarized below:

Target/Assay	IC50 Value	Species	Reference
Recombinant PKC $\theta$ enzyme activity	0.48 nM	Human	[1][2][3]
CD3/CD28-induced IL-2 gene transcription (Jurkat T cells)	14 nM	Human	
Proliferation of primary T cells	17 nM	Human	
Concanavalin A-induced IL-2 production (splenocytes)	8.9 nM	Rat	
Concanavalin A-induced IL-2 production (PBMCs)	10.5 nM	Monkey	

Q3: In which experimental models has **AS2521780** been used?

**AS2521780** has been utilized in a variety of in vitro and in vivo models to study T-cell mediated immunity and inflammation. These include:

- In vitro:
  - Jurkat T-cell lines to study IL-2 gene transcription[1][2][3][4].
  - Human primary T-cells to assess proliferation[1][2][7].
  - Rat splenocytes and monkey peripheral blood mononuclear cells (PBMCs) to measure cytokine production[1][2][3][4].
- In vivo:

- Rat models of adjuvant-induced arthritis, where it reduced paw swelling[1][7].
- Rat and non-human primate models of organ transplantation, where it prolonged graft survival[8].

## Troubleshooting Inconsistent Results

Inconsistent results in experiments involving **AS2521780** can arise from various factors, from reagent handling to experimental design. This section provides guidance on common issues.

### **Problem 1: Higher than expected IC50 values or lack of inhibitory effect.**

Potential Cause	Troubleshooting Suggestion
Compound Instability or Degradation	Ensure AS2521780 is stored correctly, protected from light and moisture. Prepare fresh stock solutions in an appropriate solvent (e.g., DMSO) for each experiment and avoid repeated freeze-thaw cycles.
Incorrect Compound Concentration	Verify the initial concentration of your stock solution. Use recently calibrated pipettes for dilutions. Perform a dose-response curve to determine the optimal concentration for your specific cell type and assay conditions.
Cell Health and Viability	Poor cell health can lead to variable responses. Ensure cells are healthy, have high viability (>90%), and are in the logarithmic growth phase before starting the experiment.
Suboptimal Cell Stimulation	The inhibitory effect of AS2521780 is dependent on T-cell activation. Ensure your method of stimulation (e.g., anti-CD3/CD28 antibodies, PMA/Ionomycin) is robust and consistent. Titrate your stimulants to find the optimal concentration for activation.
High Cell Density	An excessive number of cells can diminish the apparent potency of the inhibitor. Optimize cell seeding density to ensure a sufficient inhibitor-to-cell ratio.

## Problem 2: High variability between experimental replicates.

Potential Cause	Troubleshooting Suggestion
Inconsistent Cell Plating	Ensure uniform cell seeding across all wells. Mix the cell suspension thoroughly before and during plating to prevent settling.
Edge Effects in Multi-well Plates	Edge effects can cause variability in cell growth and response. To minimize this, avoid using the outer wells of the plate or fill them with sterile media or PBS to maintain humidity.
Inconsistent Reagent Addition	Use a multichannel pipette for adding reagents to minimize timing differences between wells. Ensure all reagents are at the correct temperature and well-mixed before addition.
Contamination	Microbial contamination can significantly impact T-cell function. Regularly check cell cultures for any signs of contamination and practice good aseptic technique.

### **Problem 3: Unexpected or off-target effects observed.**

Potential Cause	Troubleshooting Suggestion
Solvent Toxicity	High concentrations of solvents like DMSO can be toxic to cells. Ensure the final solvent concentration in your culture medium is low (typically $\leq 0.1\%$ ) and include a vehicle-only control in your experiments.
Non-specific Inhibition	While AS2521780 is highly selective for PKC $\theta$ , at very high concentrations, off-target effects on other kinases cannot be entirely ruled out. Use the lowest effective concentration of the inhibitor and consider including control experiments with inhibitors of other related kinases if off-target effects are suspected.
Cell Line-Specific Responses	Different cell lines can have varying expression levels of PKC $\theta$ and other signaling molecules, leading to different responses. Characterize the expression of key pathway components in your cell line of choice.

## Experimental Protocols

### T-Cell Proliferation Assay using CFSE

This protocol describes a method to assess the effect of AS2521-780 on T-cell proliferation using Carboxyfluorescein succinimidyl ester (CFSE) staining and flow cytometry.

Materials:

- Human Peripheral Blood Mononuclear Cells (PBMCs) or isolated T-cells
- RPMI-1640 medium supplemented with 10% Fetal Bovine Serum (FBS), 2 mM L-glutamine, 100 U/mL penicillin, and 100  $\mu$ g/mL streptomycin
- **AS2521780**
- CFSE dye

- Anti-CD3 and Anti-CD28 antibodies (plate-bound or soluble)
- Phosphate Buffered Saline (PBS)
- Flow cytometer

#### Procedure:

- Cell Preparation: Isolate PBMCs from healthy donor blood using Ficoll-Paque density gradient centrifugation.
- CFSE Labeling:
  - Resuspend cells at  $1 \times 10^6$  cells/mL in pre-warmed PBS.
  - Add CFSE to a final concentration of 1-5  $\mu$ M and incubate for 10 minutes at 37°C, protected from light.
  - Quench the staining by adding 5 volumes of ice-cold culture medium and incubate on ice for 5 minutes.
  - Wash the cells three times with culture medium to remove excess CFSE.
- Cell Seeding and Treatment:
  - Resuspend CFSE-labeled cells in culture medium and seed in a 96-well plate at an optimized density.
  - Add varying concentrations of **AS2521780** (and a vehicle control) to the wells and pre-incubate for 1 hour at 37°C.
- T-Cell Stimulation:
  - Add anti-CD3/CD28 antibodies to stimulate T-cell proliferation.
  - Include unstimulated control wells.
- Incubation: Incubate the plate for 3-5 days at 37°C in a humidified 5% CO<sub>2</sub> incubator.

- Flow Cytometry Analysis:
  - Harvest the cells and wash with PBS.
  - Analyze the cells by flow cytometry, measuring the CFSE fluorescence in the FITC channel. Proliferation is indicated by a serial halving of CFSE fluorescence in daughter cells.

## Western Blot for Phosphorylated PKC $\theta$ Substrates

This protocol outlines a general procedure for detecting the phosphorylation of PKC $\theta$  substrates in response to T-cell activation and its inhibition by **AS2521780**.

Materials:

- Jurkat T-cells or other suitable T-cell line
- RPMI-1640 medium
- **AS2521780**
- PMA (Phorbol 12-myristate 13-acetate) and Ionomycin
- Lysis buffer (e.g., RIPA buffer) with protease and phosphatase inhibitors
- BCA Protein Assay Kit
- SDS-PAGE gels and running buffer
- Transfer buffer and PVDF membrane
- Blocking buffer (e.g., 5% non-fat dry milk or BSA in TBST)
- Primary antibody against a phosphorylated PKC substrate (e.g., phospho-MARCKS)
- Loading control primary antibody (e.g., anti- $\beta$ -actin or anti-GAPDH)
- HRP-conjugated secondary antibody

- Chemiluminescent substrate
- Imaging system

Procedure:

- Cell Culture and Treatment:
  - Culture Jurkat T-cells to the desired density.
  - Pre-treat cells with various concentrations of **AS2521780** or vehicle control for 1 hour.
- Cell Stimulation:
  - Stimulate the cells with PMA (e.g., 50 ng/mL) and Ionomycin (e.g., 1  $\mu$ M) for a predetermined optimal time (e.g., 15-30 minutes).
  - Include an unstimulated control.
- Cell Lysis:
  - Harvest the cells by centrifugation and wash with ice-cold PBS.
  - Lyse the cells in lysis buffer containing protease and phosphatase inhibitors.
  - Clarify the lysates by centrifugation.
- Protein Quantification: Determine the protein concentration of each lysate using a BCA assay.
- SDS-PAGE and Western Blotting:
  - Normalize protein amounts and prepare samples with Laemmli buffer.
  - Separate proteins by SDS-PAGE and transfer to a PVDF membrane.
  - Block the membrane with blocking buffer for 1 hour at room temperature.

- Incubate the membrane with the primary antibody against the phosphorylated PKC substrate overnight at 4°C.
- Wash the membrane with TBST.
- Incubate with the HRP-conjugated secondary antibody for 1 hour at room temperature.
- Wash the membrane again with TBST.
- Detect the signal using a chemiluminescent substrate and an imaging system.
- Stripping and Re-probing: Strip the membrane and re-probe with a loading control antibody to ensure equal protein loading.

## Visualizing Pathways and Workflows

### PKC $\theta$ Signaling Pathway in T-Cell Activation

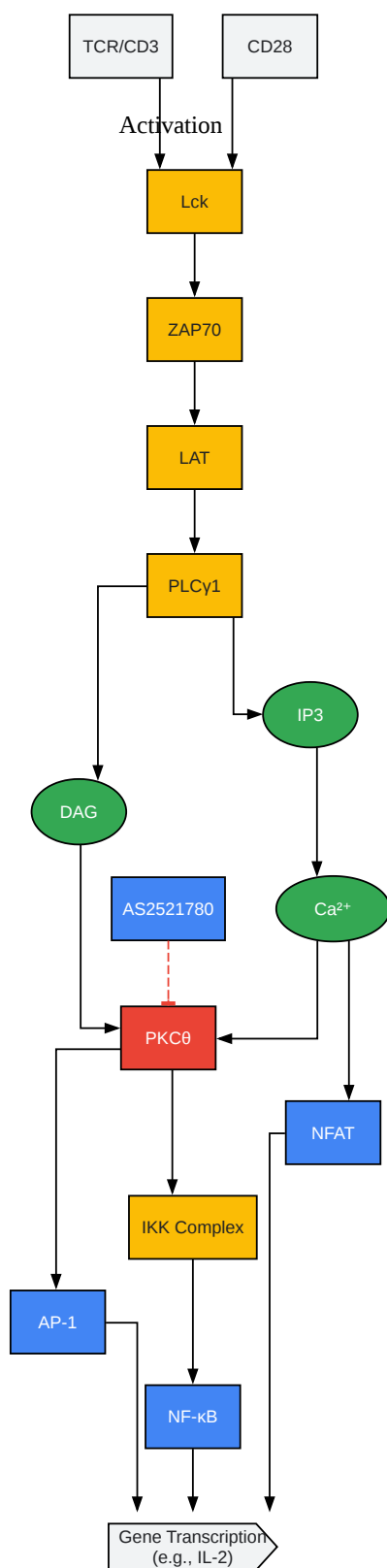

[Click to download full resolution via product page](#)

Caption: Simplified PKCθ signaling pathway in T-cell activation.

## General Experimental Workflow for AS2521780

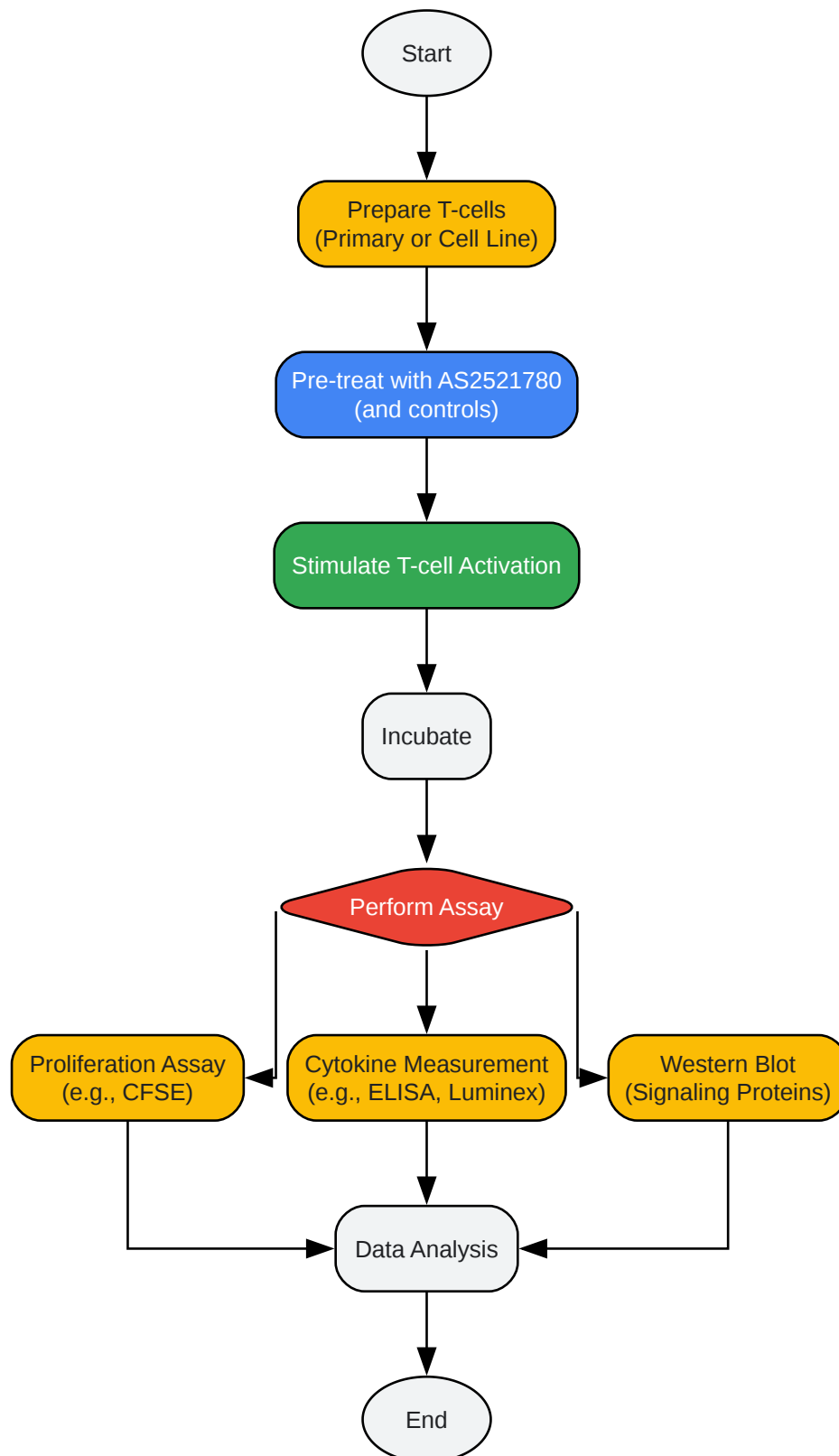

[Click to download full resolution via product page](#)

Caption: General workflow for in vitro experiments with **AS2521780**.

### Need Custom Synthesis?

BenchChem offers custom synthesis for rare earth carbides and specific isotopic labeling.

Email: [info@benchchem.com](mailto:info@benchchem.com) or [Request Quote Online](#).

## References

- 1. Troubleshooting T cell ELISPOT assay | U-CyTech [[ucytech.com](http://ucytech.com)]
- 2. T Cell Activation Bioassay (IL-2) Protocol [[worldwide.promega.com](http://worldwide.promega.com)]
- 3. Effect of AS2521780, a novel PKC $\theta$  selective inhibitor, on T cell-mediated immunity - PubMed [[pubmed.ncbi.nlm.nih.gov](http://pubmed.ncbi.nlm.nih.gov)]
- 4. [researchgate.net](http://researchgate.net) [[researchgate.net](http://researchgate.net)]
- 5. PKC- $\theta$  is a drug target for prevention of T cell-mediated autoimmunity and allograft rejection - PMC [[pmc.ncbi.nlm.nih.gov](http://pmc.ncbi.nlm.nih.gov)]
- 6. [researchgate.net](http://researchgate.net) [[researchgate.net](http://researchgate.net)]
- 7. [medchemexpress.com](http://medchemexpress.com) [[medchemexpress.com](http://medchemexpress.com)]
- 8. Effect of novel PKC $\theta$  selective inhibitor AS2521780 on acute rejection in rat and non-human primate models of transplantation - PubMed [[pubmed.ncbi.nlm.nih.gov](http://pubmed.ncbi.nlm.nih.gov)]
- To cite this document: BenchChem. [Interpreting inconsistent results in AS2521780 experiments]. BenchChem, [2026]. [Online PDF]. Available at: [<https://www.benchchem.com/product/b12425242/docs#interpreting-inconsistent-results-in-as2521780-experiments>]

---

### Disclaimer & Data Validity:

The information provided in this document is for Research Use Only (RUO) and is strictly not intended for diagnostic or therapeutic procedures. While BenchChem strives to provide accurate protocols, we make no warranties, express or implied, regarding the fitness of this product for every specific experimental setup.

**Technical Support:** The protocols provided are for reference purposes. Unsure if this reagent suits your experiment?

**Need Industrial/Bulk Grade?** [Request Custom Synthesis Quote](#)

## BenchChem

Our mission is to be the trusted global source of essential and advanced chemicals, empowering scientists and researchers to drive progress in science and industry.

### Contact

Address: 3281 E Guasti Rd  
Ontario, CA 91761, United States  
Phone: (601) 213-4426  
Email: [info@benchchem.com](mailto:info@benchchem.com)

[Contact our Ph.D. Support Team for a compatibility check](#)