

# Technical Support Center: Flow Cytometry Compensation with Novel Compounds and Viability Dyes

**Author:** BenchChem Technical Support Team. **Date:** April 2026

## Compound of Interest

Compound Name: (R)-HH2853  
CAS No.: 2202678-06-4  
Cat. No.: B12424017

[Get Quote](#)

This technical support center provides troubleshooting guidance and frequently asked questions (FAQs) for researchers encountering compensation issues in flow cytometry, particularly when working with novel fluorescent compounds like **(R)-HH2853** and various viability dyes.

## Troubleshooting Guides

Question: I'm seeing unexpected double-positive populations after staining with **(R)-HH2853** and a viability dye. What's causing this?

Answer: This is a classic sign of spectral overlap between **(R)-HH2853** and your viability dye, leading to improper compensation. When the emission spectrum of one fluorochrome spills into the detector designated for another, it creates artificial double-positive events.<sup>[1][2]</sup> To resolve this, it is crucial to run single-stain compensation controls for both **(R)-HH2853** and the viability dye to accurately calculate and apply the compensation matrix.<sup>[1][3]</sup>

Question: My compensation for the viability dye looks incorrect, leading to poor discrimination between live and dead cells. How can I fix this?

Answer: Inaccurate viability dye compensation can stem from several factors:

- Inadequate Positive Control: For proper compensation, a distinct positive population is essential.[2] If you have very few dead cells in your sample, the positive signal will be too dim to set compensation correctly.[2]
  - Solution: Prepare a dedicated single-stain control for the viability dye where a portion of the cells has been heat-killed (e.g., 5-10 minutes at 95°C) to ensure a bright positive signal.[2][4]
- Incorrect Compensation Control Type: Not all compensation controls are suitable for all viability dyes.
  - Solution: For amine-reactive viability dyes, use either cells (a mix of live and heat-killed) or specialized amine-reactive compensation beads.[4][5][6] For DNA-binding dyes like 7-AAD or PI, you must use cells as compensation beads cannot bind these dyes.[4]
- Autofluorescence Differences: The autofluorescence of live and dead cells can differ, affecting compensation accuracy, especially with DNA-binding dyes where this issue is more pronounced.[5]
  - Solution: Using a fixable amine-reactive dye and appropriate compensation beads can mitigate this issue as the beads provide a consistent negative population.[5][6]

Question: I don't have the spectral information for my novel compound, **(R)-HH2853**. How do I approach multicolor panel design and compensation?

Answer: When working with an uncharacterized fluorescent compound, a systematic approach is necessary:

- Determine Spectral Properties: First, attempt to find any available data on the excitation and emission spectra of **(R)-HH2853** from the manufacturer or literature. If unavailable, you may need to run spectral scans on a spectral flow cytometer.

- **Single-Stain Analysis:** Stain a sample with only **(R)-HH2853** and run it on your cytometer. Observe which detectors show the most significant signal and any spillover into other channels. This will give you an empirical understanding of its emission profile.
- **Panel Design:** Based on the observed emission profile, choose other fluorochromes for your panel that have minimal spectral overlap with **(R)-HH2853**. Utilize online spectral analyzers to visualize potential overlaps with commercially available dyes.
- **Rigorous Compensation:** It is critical to prepare a single-stain control for **(R)-HH2853** to compensate it against all other fluorochromes in your panel.

## Frequently Asked Questions (FAQs)

Q1: What is spectral overlap and why does it require compensation?

A1: Fluorochromes emit light over a range of wavelengths, not just at their peak emission. Spectral overlap, or spillover, occurs when the emission spectrum of one fluorochrome is detected in the channel designated for another.<sup>[1][2]</sup> Compensation is a mathematical correction that subtracts the unwanted signal from the primary detector, ensuring that the measured signal is specific to the intended fluorochrome.<sup>[1][2]</sup>

Q2: What are the fundamental rules for creating accurate compensation controls?

A2: For accurate compensation, your single-stain controls must adhere to the following principles<sup>[2][3]</sup>:

- **Same Fluorochrome:** The fluorochrome in the compensation control must be the exact same one used in your experiment.<sup>[3]</sup>
- **Identical Autofluorescence:** The positive and negative populations in your control should have the same autofluorescence. This is why using compensation beads is often recommended, as they provide uniform positive and negative populations.<sup>[5]</sup>
- **Sufficient Brightness:** The positive control signal must be at least as bright as, or brighter than, the signal you expect in your fully stained sample.<sup>[2]</sup>

- One Fluorochrome per Control: Each compensation control should be stained with only one fluorochrome.[1]

Q3: Can I use compensation beads for all viability dyes?

A3: No. Standard antibody-capture compensation beads will not work for most viability dyes. You need to use the correct type of control for your specific dye[4][5]:

- Amine-Reactive Dyes (e.g., Fixable Viability Dyes): Use amine-reactive compensation beads or a mixture of live and heat-killed cells.[5][6]
- DNA-Binding Dyes (e.g., 7-AAD, PI, DAPI): These dyes bind to DNA and require a cellular sample with both live (negative) and dead (positive) cells. Beads cannot be used.[4]
- Enzyme-Activated Dyes (e.g., Calcein AM): These dyes stain live cells. You will need a sample of unstained (negative) and stained (positive) live cells.

Q4: Should I include the viability dye in my compensation matrix if I plan to gate out the dead cells anyway?

A4: Yes, it is best practice to always include the viability dye in your compensation matrix. While you will exclude the dead cells from your final analysis, other fluorochromes in your panel can spill into the viability dye's channel.[7] If this spillover is not corrected, you might incorrectly identify live cells as dead and exclude them from your analysis, skewing your results.[7]

## Data Presentation

Table 1: Spectral Properties of Common Viability Dyes and Placeholder for **(R)-HH2853**

Dye Name	Type	Excitation Max (nm)	Emission Max (nm)	Common Laser Line	Fixable?
(R)-HH2853	Hypothetical Fluorescent Compound	Unknown	Unknown	Unknown	Unknown
7-AAD	DNA Binding	~488, ~543	~647	Blue (488nm)	No
Propidium Iodide (PI)	DNA Binding	~488, ~535	~617	Blue (488nm)	No
DAPI	DNA Binding	~358	~461	Violet (405nm)	No
Ghost Dye™ Violet 510	Amine Reactive	~405	~510	Violet (405nm)	Yes
LIVE/DEAD™ Fixable Green	Amine Reactive	~495	~520	Blue (488nm)	Yes
Calcein AM	Enzyme Activated	~495	~515	Blue (488nm)	No

Note: The spectral properties provided are approximate and can vary slightly. Always refer to the manufacturer's data sheet for specific information.

## Experimental Protocols

### Protocol 1: Preparation of Single-Stain Compensation Controls for a Viability Dye

#### A) For Amine-Reactive Dyes (e.g., LIVE/DEAD™ Fixable Dyes):

- Prepare two cell suspensions:
  - Live Cells: A suspension of your experimental cells at the appropriate concentration.
  - Dead Cells: Take an equivalent number of cells and heat-kill them at 95°C for 5-10 minutes, then allow them to cool to room temperature.

- **Mix Live and Dead Cells:** Combine the live and heat-killed cell suspensions. A 1:1 ratio is a good starting point, but this can be adjusted to achieve a clear separation of positive and negative populations.
- **Stain with Viability Dye:** Stain the mixed cell population with the amine-reactive viability dye according to the manufacturer's protocol.
- **Wash:** Wash the cells as per the protocol.
- **Acquire:** Run the sample on the flow cytometer to set the compensation for the viability dye channel.

#### B) For DNA-Binding Dyes (e.g., 7-AAD, PI):

- **Prepare a single-cell suspension** of your experimental cells.
- **Induce Cell Death (Optional but Recommended):** If you anticipate a very low percentage of dead cells, you can treat a small aliquot of cells to induce death (e.g., heat treatment or brief fixation) and then mix it back with the live cells to ensure a sufficient positive population.
- **Stain with Viability Dye:** Just before acquisition, add the DNA-binding dye to the cell suspension at the recommended concentration. Do not wash the cells after adding the dye. [\[8\]](#)
- **Acquire:** Immediately acquire the sample on the flow cytometer.

#### Protocol 2: General Workflow for Multicolor Flow Cytometry Compensation

- **Panel Design:** Carefully select fluorochromes to minimize spectral overlap using online spectral analyzers.
- **Prepare Single-Stain Controls:** For each fluorochrome in your panel (including antibodies, viability dyes, and any fluorescent compounds like **(R)-HH2853**), prepare a separate single-stain control.
  - For antibodies, use antibody-capture beads or cells expressing the target antigen.
  - For viability dyes, follow Protocol 1.

- For **(R)-HH2853**, use a sample of cells stained only with this compound.
- Prepare Unstained Control: Always include an unstained sample of your cells to set the baseline voltage and determine the level of autofluorescence.
- Set Voltages: Use the unstained and single-stained controls to adjust the photomultiplier tube (PMT) voltages so that both the negative and positive populations are on scale and well-separated.
- Acquire Compensation Data: Run each of your single-stain controls and the unstained control, collecting a sufficient number of events for each.
- Calculate Compensation Matrix: Use the flow cytometry software's automated compensation algorithm to calculate the spillover values and create the compensation matrix.
- Apply Compensation: Apply the calculated compensation matrix to your fully stained experimental samples.
- Verify Compensation: Visually inspect the compensated data to ensure that there are no "arcs" or "smiles" in the bivariate plots, which would indicate under- or over-compensation.

## Mandatory Visualization

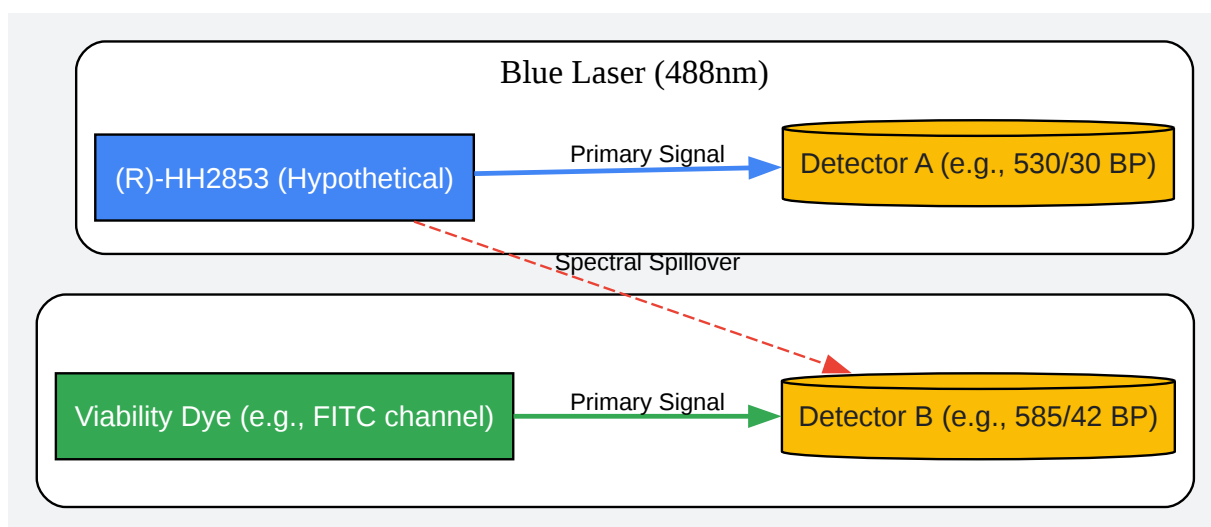

[Click to download full resolution via product page](#)

Caption: Diagram illustrating spectral overlap.

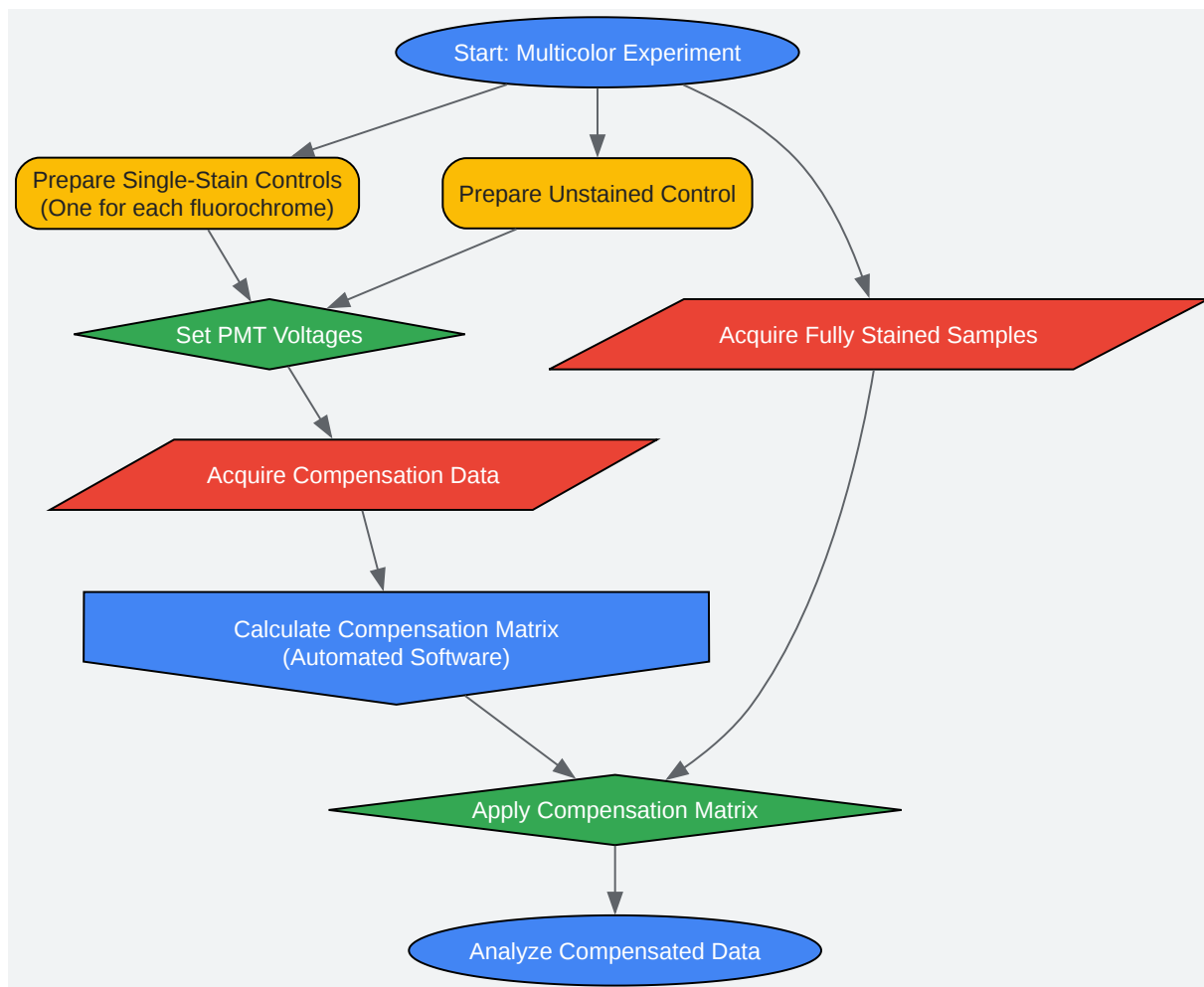

[Click to download full resolution via product page](#)

Caption: Experimental workflow for flow cytometry compensation.

### Need Custom Synthesis?

BenchChem offers custom synthesis for rare earth carbides and specific isotopic labeling.

Email: [info@benchchem.com](mailto:info@benchchem.com) or [Request Quote Online](#).

## References

- [1. bio-rad-antibodies.com \[bio-rad-antibodies.com\]](https://www.bio-rad-antibodies.com)
- [2. To dye or not to dye? Understanding the different viability dyes available for flow cytometry | Proteintech Group \[ptglab.com\]](#)
- [3. biotium.com \[biotium.com\]](https://www.biotium.com)
- [4. medkoo.com \[medkoo.com\]](https://www.medkoo.com)
- [5. Fluorescent p53 helix mimetics pairing anticancer and bioimaging properties - Biomaterials Science \(RSC Publishing\) \[pubs.rsc.org\]](#)
- [6. m.youtube.com \[m.youtube.com\]](https://m.youtube.com)
- [7. welcome.cytekbio.com \[welcome.cytekbio.com\]](https://welcome.cytekbio.com)
- [8. medchemexpress.com \[medchemexpress.com\]](https://www.medchemexpress.com)
- To cite this document: BenchChem. [Technical Support Center: Flow Cytometry Compensation with Novel Compounds and Viability Dyes]. BenchChem, [2026]. [Online PDF]. Available at: [<https://www.benchchem.com/product/b12424017/docs#technical-support-center-flow-cytometry-compensation-with-novel-compounds-and-viability-dyes>]

---

### Disclaimer & Data Validity:

The information provided in this document is for Research Use Only (RUO) and is strictly not intended for diagnostic or therapeutic procedures. While BenchChem strives to provide accurate protocols, we make no warranties, express or implied, regarding the fitness of this product for every specific experimental setup.

**Technical Support:** The protocols provided are for reference purposes. Unsure if this reagent suits your experiment?

**Need Industrial/Bulk Grade?** [Request Custom Synthesis Quote](#)

# BenchChem

Our mission is to be the trusted global source of essential and advanced chemicals, empowering scientists and researchers to drive progress in science and industry.

## Contact

Address: 3281 E Guasti Rd

Ontario, CA 91761, United States

Phone: (601) 213-4426

Email: [info@benchchem.com](mailto:info@benchchem.com)

[Contact our Ph.D. Support Team for a compatibility check](#)