

TAMRA Probes for Flow Cytometry: Application Notes and Protocols

Author: BenchChem Technical Support Team. **Date:** April 2026

Compound of Interest

Compound Name: TAMRA-probe 1

Cat. No.: B12424536

[Get Quote](#)

For Researchers, Scientists, and Drug Development Professionals

Introduction to TAMRA Probes in Flow Cytometry

Tetramethylrhodamine (TAMRA) is a bright, orange-red fluorescent dye that has become a valuable tool in a wide range of biological research applications, including flow cytometry.^{[1][2]} As a member of the rhodamine family of dyes, TAMRA exhibits excellent photostability and a strong fluorescence signal, making it well-suited for experiments requiring sensitive and durable fluorescent labeling.^[2] Its excitation and emission spectra are compatible with standard laser lines available on most commercial flow cytometers, typically excited by a yellow-green laser (561 nm) and detected using a bandpass filter around 585 nm.^[3]

TAMRA can be conjugated to various biomolecules, such as antibodies, peptides, and ligands, enabling researchers to probe specific cellular targets and processes.^[1] In flow cytometry, TAMRA-conjugated probes are instrumental in immunophenotyping, analyzing cellular uptake and internalization, quantifying receptor binding, and investigating cell signaling pathways. This document provides detailed application notes and experimental protocols for the use of TAMRA probes in flow cytometry.

Data Presentation

Spectral Properties of TAMRA

Parameter	Value
Maximum Excitation (λ_{ex})	~555 nm
Maximum Emission (λ_{em})	~580 nm
Molar Extinction Coefficient (ϵ)	~95,000 $\text{cm}^{-1}\text{M}^{-1}$
Recommended Laser Line	561 nm (Yellow-Green)
Common Emission Filter	585/42 nm Bandpass

Representative Quantitative Data for TAMRA-Labeled Probes in Flow Cytometry

The following table provides example data from a receptor binding study using a TAMRA-labeled ligand (D5-TAMRA) targeting the Epidermal Growth Factor Receptor (EGFR) on different cell lines with varying EGFR expression levels. Data is presented as Mean Fluorescence Intensity (MFI).

Cell Line	EGFR Expression Level	Treatment	Mean Fluorescence Intensity (MFI)
MDA-MB-468	High	Vehicle Control	69
D4-TAMRA (Negative Control)	74		
D5-TAMRA (EGFR-binding)	18,968		
MDA-MB-231	Medium	Vehicle Control	64
D4-TAMRA (Negative Control)	77		
D5-TAMRA (EGFR-binding)	1,630		
MCF-7	Low	Vehicle Control	76
D4-TAMRA (Negative Control)	90		
D5-TAMRA (EGFR-binding)	471		

Data adapted from a study evaluating D5-TAMRA binding to cell-surface EGFR.

Experimental Protocols

Protocol 1: Conjugation of TAMRA to an Antibody

This protocol outlines the steps for covalently labeling an antibody with a TAMRA-NHS ester.

Materials:

- Antibody of interest (in an amine-free buffer like PBS)
- TAMRA-NHS ester
- Anhydrous Dimethylsulfoxide (DMSO)

- 1 M Sodium Bicarbonate
- Desalting column (e.g., Sephadex G-25)
- Phosphate-Buffered Saline (PBS)
- Spectrophotometer

Procedure:

- Antibody Preparation:
 - Dissolve or dialyze the antibody into PBS at a concentration of 1-10 mg/mL.
 - Add 1/10th volume of 1 M Sodium Bicarbonate to the antibody solution to raise the pH to 8.3, which is optimal for the conjugation reaction.
- TAMRA-NHS Ester Preparation:
 - Immediately before use, dissolve the TAMRA-NHS ester in DMSO to a concentration of 10 mg/mL.
- Conjugation Reaction:
 - Add a 10- to 20-fold molar excess of the dissolved TAMRA-NHS ester to the antibody solution. The optimal molar ratio may need to be determined empirically.
 - Incubate the reaction for 1-2 hours at room temperature, protected from light.
- Purification of the Conjugate:
 - Separate the TAMRA-conjugated antibody from unconjugated dye using a desalting column pre-equilibrated with PBS.
 - Collect the colored fractions, which contain the labeled antibody.
- Determination of Degree of Labeling (DOL):

- Measure the absorbance of the purified conjugate at 280 nm (for the protein) and 555 nm (for TAMRA).
- Calculate the protein concentration, correcting for the absorbance of TAMRA at 280 nm.
- Calculate the concentration of TAMRA using its molar extinction coefficient.
- The DOL is the molar ratio of TAMRA to the antibody. An optimal DOL for antibodies is typically between 3 and 7.

Protocol 2: Cell Surface Staining with a TAMRA-Conjugated Antibody

This protocol describes the staining of cell surface markers for flow cytometric analysis.

Materials:

- Single-cell suspension (e.g., peripheral blood mononuclear cells or cultured cells)
- TAMRA-conjugated antibody
- Flow Cytometry Staining Buffer (e.g., PBS with 1% BSA and 0.1% sodium azide)
- Fc receptor blocking solution (optional)
- Viability dye (optional)
- 12 x 75 mm polystyrene tubes

Procedure:

- Cell Preparation:
 - Prepare a single-cell suspension at a concentration of 1×10^7 cells/mL in ice-cold Flow Cytometry Staining Buffer.
 - If using cells with high Fc receptor expression (e.g., B cells, macrophages), incubate with an Fc blocking reagent for 10-15 minutes at 4°C.

- Staining:
 - Aliquot 100 μL of the cell suspension (1×10^6 cells) into flow cytometry tubes.
 - Add the predetermined optimal concentration of the TAMRA-conjugated antibody.
 - Vortex gently and incubate for 20-30 minutes at 4°C in the dark.
- Washing:
 - Add 2 mL of ice-cold Flow Cytometry Staining Buffer to each tube.
 - Centrifuge at 300-400 x g for 5 minutes at 4°C and discard the supernatant.
 - Repeat the wash step.
- Data Acquisition:
 - Resuspend the cell pellet in 500 μL of Flow Cytometry Staining Buffer.
 - If a viability dye is used, add it according to the manufacturer's protocol.
 - Acquire data on a flow cytometer using the appropriate laser (e.g., 561 nm) and emission filter (e.g., 585/42 bandpass) for TAMRA.

Protocol 3: Intracellular Staining with a TAMRA-Conjugated Probe

This protocol is for the detection of intracellular targets.

Materials:

- Single-cell suspension
- TAMRA-conjugated probe
- Fixation Buffer (e.g., 4% paraformaldehyde in PBS)
- Permeabilization Buffer (e.g., PBS with 0.1% Saponin or 0.5% Triton X-100)

- Flow Cytometry Staining Buffer

Procedure:

- Cell Surface Staining (Optional):
 - If co-staining for surface markers, perform the cell surface staining protocol first.
- Fixation:
 - After the final wash from the surface staining, resuspend the cell pellet in 100 μ L of Fixation Buffer.
 - Incubate for 20 minutes at room temperature, protected from light.
- Permeabilization:
 - Wash the cells twice with 2 mL of Flow Cytometry Staining Buffer.
 - Resuspend the fixed cells in 100 μ L of Permeabilization Buffer.
- Intracellular Staining:
 - Add the TAMRA-conjugated probe for the intracellular target.
 - Incubate for 30-45 minutes at room temperature in the dark.
- Washing:
 - Wash the cells twice with 2 mL of Permeabilization Buffer.
- Data Acquisition:
 - Resuspend the cell pellet in 500 μ L of Flow Cytometry Staining Buffer.
 - Acquire data on a flow cytometer.

Mandatory Visualizations

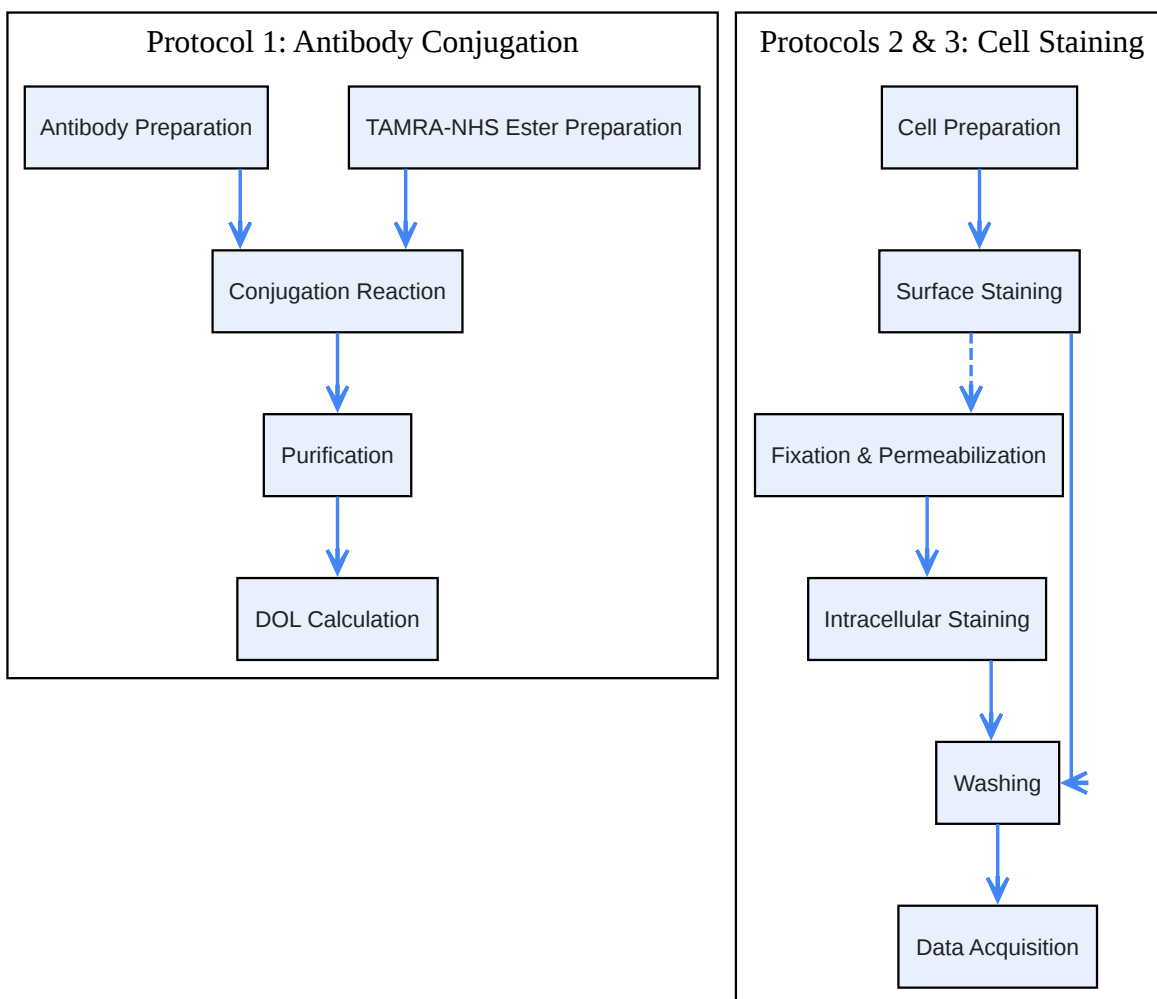

[Click to download full resolution via product page](#)

Caption: General experimental workflows for TAMRA probe conjugation and cell staining.

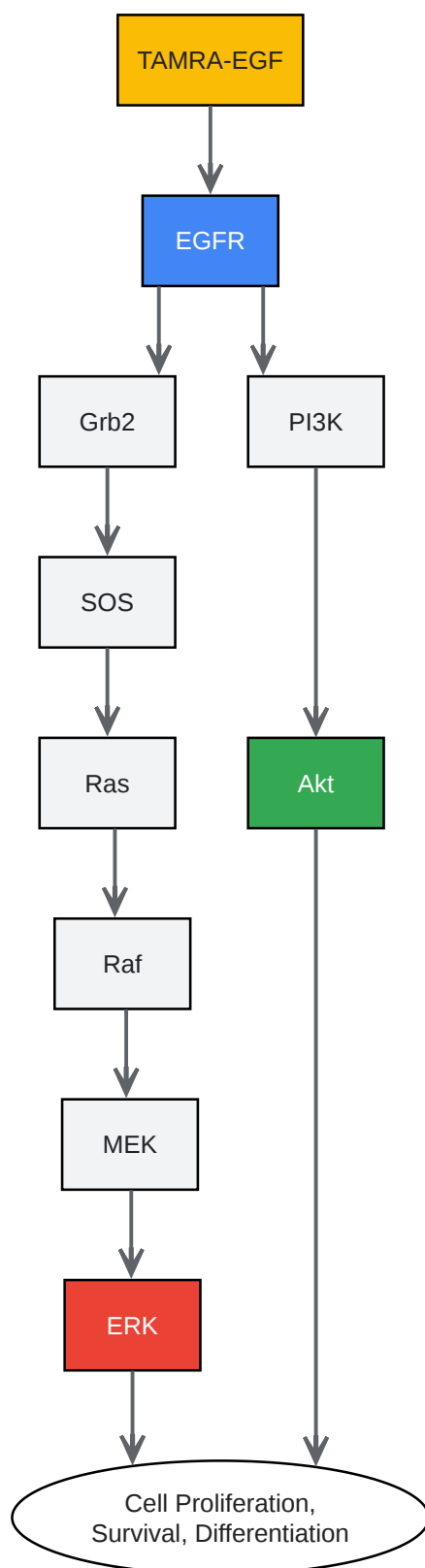

[Click to download full resolution via product page](#)

Caption: Simplified EGFR signaling pathway measurable by flow cytometry.

Application Example: Analysis of EGFR Signaling using a TAMRA-labeled Ligand

This example demonstrates how to use a TAMRA-labeled Epidermal Growth Factor (EGF) to study receptor binding and downstream signaling in A431 cells, which overexpress EGFR.

Experimental Design:

- **Stimulation:** A431 cells are stimulated with TAMRA-EGF to induce EGFR signaling.
- **Staining:** Cells are then fixed, permeabilized, and stained with fluorescently-labeled antibodies against phosphorylated downstream targets, such as p-ERK and p-Akt.
- **Analysis:** Flow cytometry is used to quantify the binding of TAMRA-EGF and the levels of p-ERK and p-Akt in stimulated versus unstimulated cells.

Protocol:

- **Cell Culture:** Culture A431 cells to 70-80% confluency.
- **Starvation:** Serum-starve the cells for 12-24 hours prior to the experiment to reduce basal signaling.
- **Stimulation:**
 - Harvest and wash the cells.
 - Resuspend the cells in serum-free media.
 - Stimulate the cells with TAMRA-EGF (e.g., 100 ng/mL) for various time points (e.g., 0, 5, 15, 30 minutes) at 37°C. An unstimulated control should be included.
- **Fixation and Permeabilization:**
 - Immediately after stimulation, fix the cells with 4% paraformaldehyde for 20 minutes at room temperature.
 - Permeabilize the cells with ice-cold 90% methanol for 30 minutes on ice.

- Staining:
 - Wash the cells with Flow Cytometry Staining Buffer.
 - Incubate the cells with a cocktail of anti-p-ERK (e.g., Alexa Fluor 488 conjugate) and anti-p-Akt (e.g., Alexa Fluor 647 conjugate) antibodies for 1 hour at room temperature.
- Data Acquisition and Analysis:
 - Wash the cells and resuspend in Flow Cytometry Staining Buffer.
 - Acquire data on a flow cytometer.
 - Analyze the MFI of TAMRA to assess EGF binding and the MFI of the other fluorophores to quantify the levels of p-ERK and p-Akt.

Expected Results:

- A time-dependent increase in the MFI of p-ERK and p-Akt in the TAMRA-positive (EGF-bound) cell population compared to the unstimulated control. This would indicate the activation of the EGFR signaling cascade upon ligand binding.

This comprehensive approach allows for the simultaneous analysis of ligand-receptor interaction and the downstream signaling events at a single-cell level, providing valuable insights for researchers in cell biology and drug development.

Need Custom Synthesis?

BenchChem offers custom synthesis for rare earth carbides and specific isotopic labeling.

Email: info@benchchem.com or [Request Quote Online](#).

References

- [1. researchgate.net \[researchgate.net\]](https://www.researchgate.net)
- [2. EGFR Signaling Pathway \[pfocr.wikipathways.org\]](https://pfocr.wikipathways.org)
- [3. flowcytometry.utoronto.ca \[flowcytometry.utoronto.ca\]](https://flowcytometry.utoronto.ca)

- To cite this document: BenchChem. [TAMRA Probes for Flow Cytometry: Application Notes and Protocols]. BenchChem, [2026]. [Online PDF]. Available at: [<https://www.benchchem.com/product/b12424536/docs#tamra-probes-for-flow-cytometry-application-notes-and-protocols>]

Disclaimer & Data Validity:

The information provided in this document is for Research Use Only (RUO) and is strictly not intended for diagnostic or therapeutic procedures. While BenchChem strives to provide accurate protocols, we make no warranties, express or implied, regarding the fitness of this product for every specific experimental setup.

Technical Support: The protocols provided are for reference purposes. Unsure if this reagent suits your experiment?

Need Industrial/Bulk Grade? [Request Custom Synthesis Quote](#)

BenchChem

Our mission is to be the trusted global source of essential and advanced chemicals, empowering scientists and researchers to drive progress in science and industry.

Contact

Address: 3281 E Guasti Rd
Ontario, CA 91761, United States
Phone: (601) 213-4426
Email: info@benchchem.com

[Contact our Ph.D. Support Team for a compatibility check](#)