

Technical Support Center: ABL-L Protocol for High-Throughput Screening

Author: BenchChem Technical Support Team. **Date:** April 2026

Compound of Interest

Compound Name: ABL-L
Cat. No.: B12423841

[Get Quote](#)

This technical support center provides troubleshooting guidance and answers to frequently asked questions for the **ABL-L** (ABL Luminescence) protocol, a high-throughput screening assay designed to measure the kinase activity of ABL (Abelson murine leukemia viral oncogene homolog 1).

Frequently Asked Questions (FAQs)

Q1: What is the fundamental principle of the **ABL-L** assay?

The **ABL-L** assay is a luminescence-based kinase assay designed for high-throughput screening. It quantifies the kinase activity of ABL by measuring the amount of ATP remaining in the reaction after the kinase has phosphorylated its substrate. The amount of ATP is detected by a luciferase/luciferin reaction, where the light output is inversely proportional to ABL kinase activity.^[1]

Q2: What are the critical reagents for this assay?

The essential components for the **ABL-L** assay include:

- ABL Kinase enzyme

- A specific peptide substrate (e.g., Abltide)[1]
- ATP (Adenosine triphosphate)
- Kinase buffer
- A detection reagent containing luciferase and luciferin (e.g., ADP-Glo™)[1]
- Test compounds (inhibitors or activators)

Q3: What type of microplates are recommended for the **ABL-L** assay?

For luminescence-based assays, white opaque microplates are recommended to maximize the light signal and prevent crosstalk between wells.[2]

Q4: How should I prepare my test compounds?

If your test compounds are soluble in DMSO, prepare a concentrated stock solution in 100% DMSO. Subsequent dilutions should be made in the kinase assay buffer, ensuring the final DMSO concentration is consistent across all wells and does not exceed a level that affects enzyme activity (typically $\leq 1\%$).[3]

Q5: What is the purpose of a Z' factor, and what is a good value?

The Z' factor is a statistical measure of the quality of a high-throughput screening assay. It reflects the separation between the positive and negative control signals. An assay with a Z' factor between 0.5 and 1.0 is considered excellent and robust for HTS.

Experimental Protocols

General **ABL-L** Kinase Assay Protocol

This protocol provides a general procedure for performing the **ABL-L** kinase assay in a 384-well plate format.

- Reagent Preparation:
 - Prepare the 1x Kinase Assay Buffer.

- Dilute the ABL kinase, substrate, and ATP to their final concentrations in the kinase assay buffer.
- Prepare serial dilutions of test compounds and control inhibitors (e.g., Staurosporine)[3].
- Assay Plate Setup:
 - Add 5 μL of the diluted test compounds or controls to the appropriate wells of a 384-well white plate.[4]
 - Add 5 μL of the ABL kinase solution to each well.[4]
 - Incubate for 15 minutes at room temperature.[4]
- Kinase Reaction Initiation:
 - Add 10 μL of the ATP and substrate mixture to each well to start the kinase reaction.[4]
 - Incubate for 60 minutes at 30°C.[3]
- Signal Detection:
 - Add 25 μL of the ADP-Glo™ reagent to each well to stop the kinase reaction and deplete the remaining ATP.[3]
 - Incubate for 40-45 minutes at room temperature.[1][3]
 - Add 50 μL of the Kinase Detection Reagent to each well to generate the luminescent signal.[3]
 - Incubate for 30-45 minutes at room temperature, protected from light.[1][3]
- Data Acquisition:
 - Read the luminescence on a plate reader. The integration time is typically set to 0.5-1 second per well.[1]

Data Presentation

Table 1: Example IC50 Values for ABL Kinase Inhibitors

Compound	Target	IC50 (nM)
Staurosporine	ABL1 (T315I)	28.91[1]
Staurosporine	ABL2	38[3]
NSC689857	p210 (BCR-ABL)	12,620[5]
NSC681152	p210 (BCR-ABL)	2,640[5]

Table 2: Troubleshooting Reference for Assay Signal

Issue	Possible Cause	Recommended Solution
High Signal (Low Kinase Activity)	Inactive enzyme	Check enzyme storage and handling. Use a fresh aliquot.
Inhibitor concentration too high	Review dilution series and calculations.	
Incorrect ATP concentration	Verify ATP concentration.	
Low Signal (High Kinase Activity)	Insufficient inhibitor	Check inhibitor concentration and purity.
Enzyme concentration too high	Optimize enzyme titration.	
High Variability	Pipetting errors	Use calibrated pipettes; ensure proper mixing.[2]
Edge effects	Avoid using the outer wells of the plate or use a different plate layout.	
Reagent instability	Ensure reagents are properly thawed and mixed before use. [2]	

Visualizations

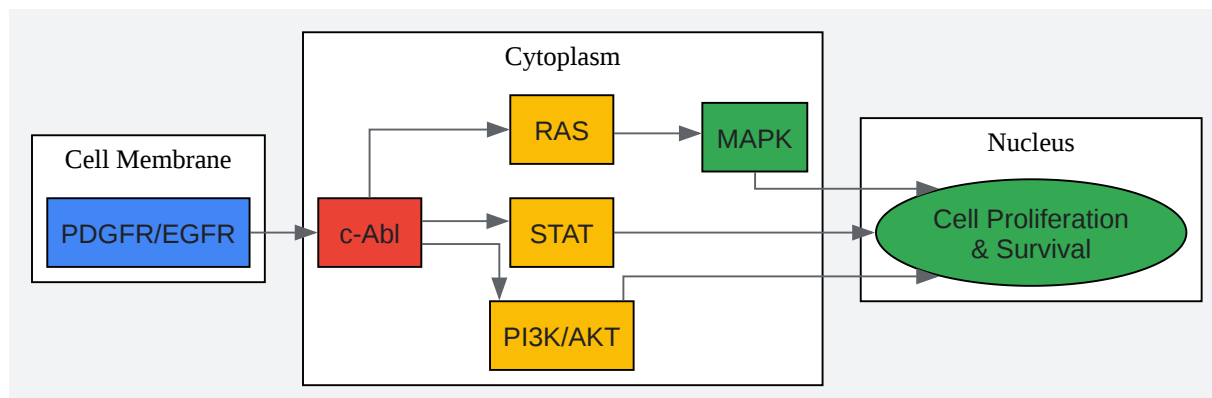

[Click to download full resolution via product page](#)

Caption: Simplified ABL kinase signaling pathway.

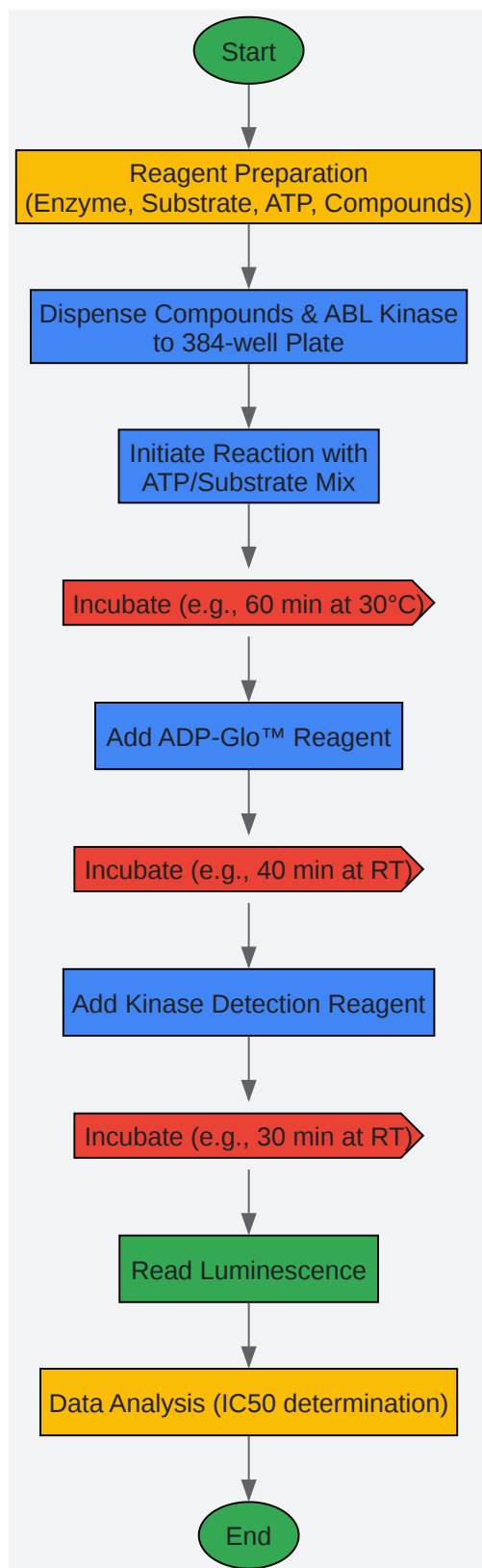

[Click to download full resolution via product page](#)

Caption: Experimental workflow for the **ABL-L** HTS protocol.

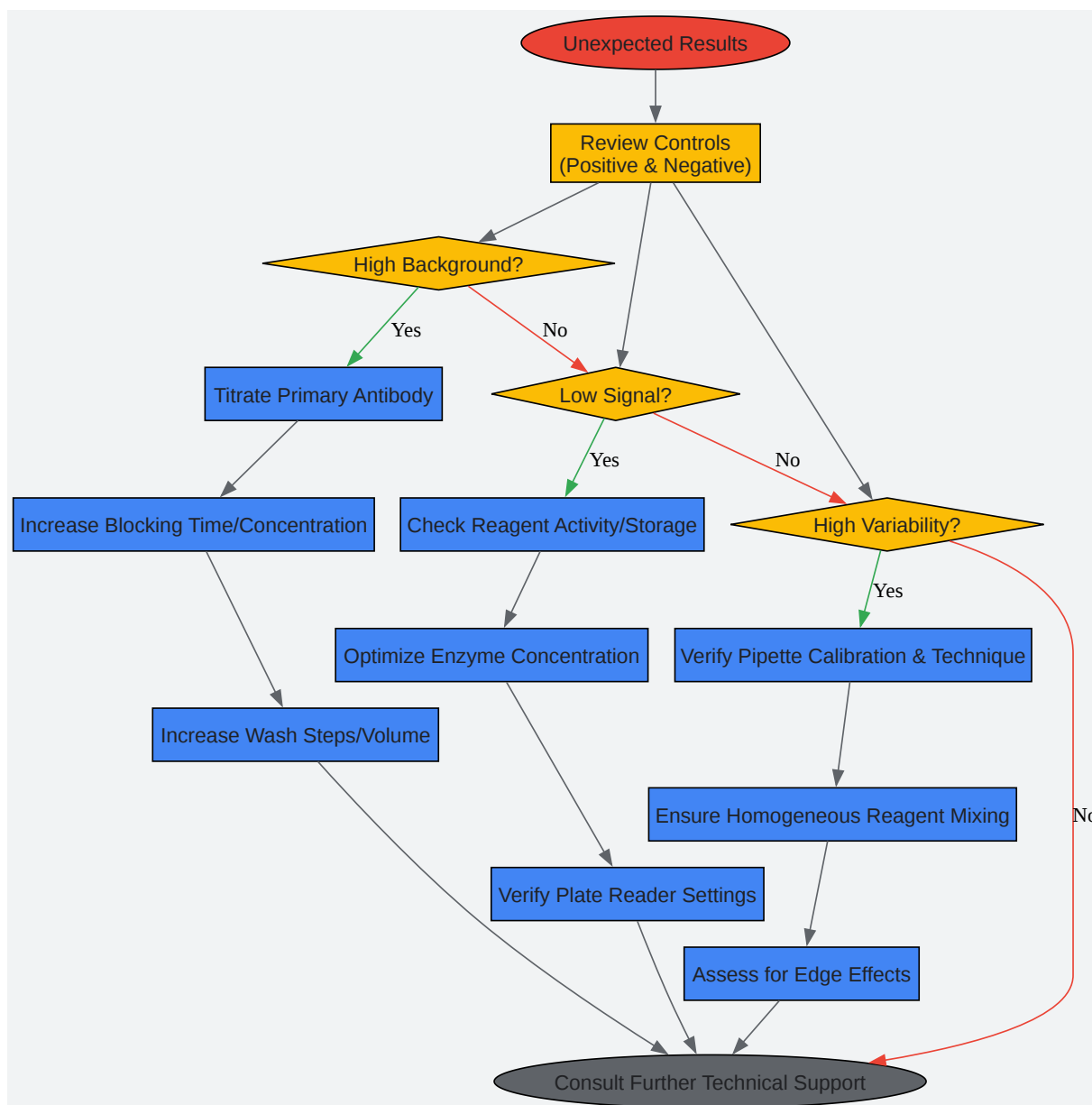

[Click to download full resolution via product page](#)

Caption: Logical troubleshooting workflow for HTS assays.

Troubleshooting Guide

Q: My assay has a high background signal. What should I do?

A high background can obscure the signal from your kinase reaction. Here are some common causes and solutions:

- **Contaminated Reagents:** Ensure that all buffers and water are of high purity and free from contaminants like dust or pollen.[\[6\]](#)
- **Sub-optimal Antibody/Reagent Concentration:** If using an antibody-based detection method, the primary antibody concentration may be too high. Titrate the antibody to find the optimal concentration that provides a good signal without increasing the background.
- **Insufficient Blocking or Washing:** Inadequate blocking or washing steps can lead to non-specific binding. Increase the incubation time for blocking or the number and volume of washes.

Q: The luminescent signal is very low or absent, even in my positive controls. What could be the problem?

A low or absent signal can indicate a problem with one of the core components of the assay.

- **Inactive Enzyme:** ABL kinase is sensitive to storage conditions and freeze-thaw cycles. Ensure the enzyme has been stored correctly at the recommended temperature and has not undergone excessive freeze-thaw cycles.[\[2\]](#) Test a fresh aliquot of the enzyme.
- **Incorrect Plate Reader Settings:** Verify that the plate reader is set to "luminescence" mode and that no emission filters are in place. The integration time may also need to be optimized.[\[3\]](#)
- **Reagent Omission or Degradation:** Double-check that all reagents, especially the ATP and detection reagents, were added in the correct order and volume. Ensure that reagents were thawed completely and mixed gently before use.[\[2\]](#)

Q: I'm observing high variability between replicate wells. How can I improve my assay's precision?

High variability can make it difficult to confidently identify hits.

- **Pipetting Inaccuracy:** Small volumes are prone to pipetting errors. Ensure that all pipettes are properly calibrated. When pipetting, do so gently against the wall of the wells to avoid air bubbles.[2]
- **Incomplete Reagent Mixing:** Ensure that all reagent solutions are homogeneous before and during dispensing into the plate.
- **Plate Edge Effects:** Temperature and evaporation gradients across the plate can cause "edge effects," where the outer wells behave differently from the inner wells. If this is suspected, avoid using the outermost rows and columns for samples and controls.

Q: My data reproducibility between plates or experimental runs is poor. What are the likely causes?

Poor reproducibility is a common challenge in HTS.[7]

- **Batch-to-Batch Reagent Variation:** Use reagents from the same lot for all plates within a single experiment. If a new batch of a critical reagent like the enzyme is used, it may require re-optimization.
- **Inconsistent Incubation Times or Temperatures:** Ensure that incubation times and temperatures are strictly controlled for all plates.[2]
- **Data Normalization Issues:** Data analysis methods are crucial for reliable results. Employ robust data normalization techniques to account for plate-to-plate variation.[8]

Need Custom Synthesis?

BenchChem offers custom synthesis for rare earth carbides and specific isotopic labeling.

Email: info@benchchem.com or [Request Quote Online](#).

References

- 1. promega.com [promega.com]

- [2. docs.abcam.com \[docs.abcam.com\]](https://docs.abcam.com)
- [3. bpsbioscience.com \[bpsbioscience.com\]](https://bpsbioscience.com)
- [4. benchchem.com \[benchchem.com\]](https://benchchem.com)
- [5. High-Throughput Screening AlphaScreen Assay for Identification of Small-Molecule Inhibitors of Ubiquitin E3 Ligase SCFSkp2-Cks1 - PMC \[pmc.ncbi.nlm.nih.gov\]](#)
- [6. buhlmannlabs.com \[buhlmannlabs.com\]](https://buhlmannlabs.com)
- [7. Application of High Throughput Technologies in the Development of Acute Myeloid Leukemia Therapy: Challenges and Progress - PMC \[pmc.ncbi.nlm.nih.gov\]](#)
- [8. CHALLENGES IN SECONDARY ANALYSIS OF HIGH THROUGHPUT SCREENING DATA - PMC \[pmc.ncbi.nlm.nih.gov\]](#)
- To cite this document: BenchChem. [Technical Support Center: ABL-L Protocol for High-Throughput Screening]. BenchChem, [2026]. [Online PDF]. Available at: [\[https://www.benchchem.com/product/b12423841/docs#technical-support-center-abl-l-protocol-for-high-throughput-screening\]](https://www.benchchem.com/product/b12423841/docs#technical-support-center-abl-l-protocol-for-high-throughput-screening)

Disclaimer & Data Validity:

The information provided in this document is for Research Use Only (RUO) and is strictly not intended for diagnostic or therapeutic procedures. While BenchChem strives to provide accurate protocols, we make no warranties, express or implied, regarding the fitness of this product for every specific experimental setup.

Technical Support: The protocols provided are for reference purposes. Unsure if this reagent suits your experiment?

Need Industrial/Bulk Grade? [Request Custom Synthesis Quote](#)

BenchChem

Our mission is to be the trusted global source of essential and advanced chemicals, empowering scientists and researchers to drive progress in science and industry.

Contact

Address: 3281 E Guasti Rd
Ontario, CA 91761, United States
Phone: (601) 213-4426
Email: info@benchchem.com

Contact our Ph.D. Support Team for a compatibility check