

Application Note: TR-FRET Assay for Characterizing "**PROTAC BRD9-binding moiety 1**"

Author: BenchChem Technical Support Team. **Date:** April 2026

Compound of Interest

Compound Name: *PROTAC BRD9-binding moiety 1*

Cat. No.: *B12423611*

[Get Quote](#)

Introduction

Proteolysis-targeting chimeras (PROTACs) are heterobifunctional molecules that induce the degradation of specific target proteins by hijacking the ubiquitin-proteasome system.[1][2][3][4] A PROTAC molecule simultaneously binds to a target protein and an E3 ubiquitin ligase, forming a ternary complex that leads to the ubiquitination and subsequent degradation of the target protein.[1][2][3][4] Bromodomain-containing protein 9 (BRD9) is an epigenetic reader protein implicated in various cancers, making it an attractive target for therapeutic intervention.[5] The development of effective BRD9-targeting PROTACs requires robust and quantitative methods to characterize their binding affinity and ternary complex formation.

Time-Resolved Fluorescence Resonance Energy Transfer (TR-FRET) is a powerful, homogeneous assay technology well-suited for studying complex biological interactions in a high-throughput format.[6][7] This application note describes a TR-FRET assay designed to measure the binding of "**PROTAC BRD9-binding moiety 1**" to the BRD9 protein, a critical first step in its mechanism of action. The assay can be configured as a competitive binding assay to determine the potency (IC50) of the PROTAC moiety for BRD9.

Assay Principle

The TR-FRET assay for BRD9 binding relies on the energy transfer between a Terbium (Tb)-labeled donor and a dye-labeled acceptor when they are brought into close proximity. In this competitive assay format, a known biotinylated ligand for the BRD9 bromodomain is used. The assay components include:

- GST-tagged BRD9 protein: The target protein.
- Terbium-labeled anti-GST antibody (Donor): Binds to the GST-tag on BRD9.
- Dye-labeled acceptor (e.g., Streptavidin-D2 or similar): Binds to the biotinylated BRD9 ligand.
- Biotinylated BRD9 ligand: A known binder to the BRD9 bromodomain.
- **"PROTAC BRD9-binding moiety 1"** (Competitor): The test compound.

When the biotinylated ligand binds to the Tb-labeled BRD9, the donor and acceptor are in close proximity, resulting in a high TR-FRET signal. **"PROTAC BRD9-binding moiety 1"** competes with the biotinylated ligand for binding to BRD9. As the concentration of the PROTAC moiety increases, it displaces the biotinylated ligand, leading to a decrease in the TR-FRET signal. The potency of the PROTAC moiety is determined by measuring the concentration-dependent decrease in the TR-FRET ratio.

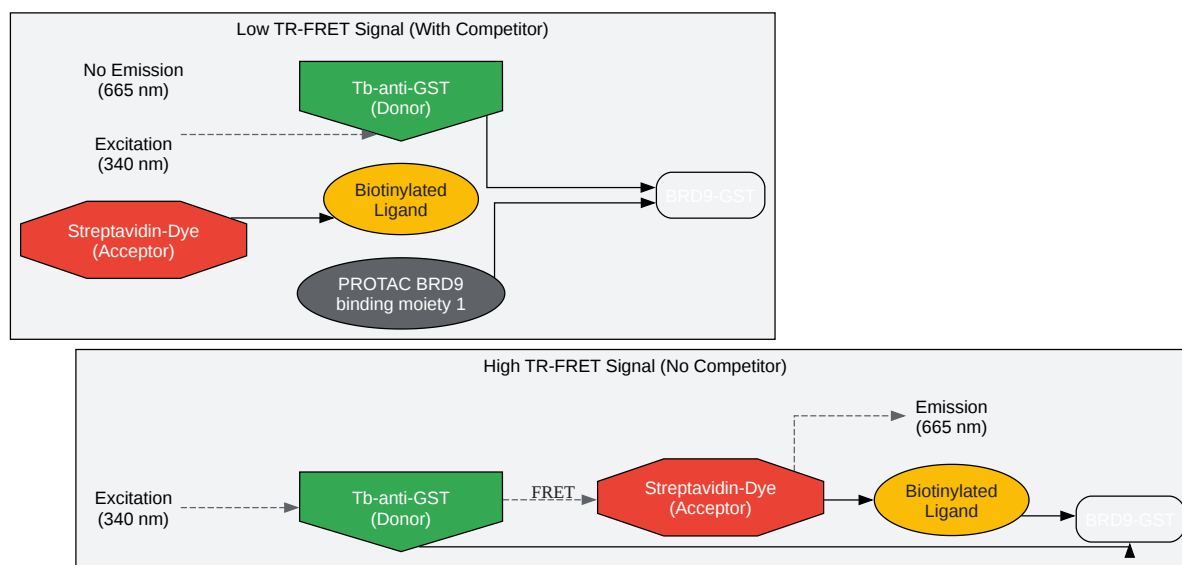

[Click to download full resolution via product page](#)

Figure 1: Principle of the competitive TR-FRET assay for BRD9 binding.

Data Presentation

The potency of "**PROTAC BRD9-binding moiety 1**" is determined by generating a dose-response curve where the TR-FRET ratio is plotted against the logarithm of the compound concentration. The IC₅₀ value, which represents the concentration of the compound required to inhibit 50% of the signal, is then calculated. The results are summarized in the table below.

Compound	IC50 (nM)	Hill Slope	R ²
PROTAC BRD9-binding moiety 1	25.5	-1.1	0.992
Control Inhibitor (e.g., BI-9564)	15.2	-1.0	0.995

Table 1: Hypothetical binding affinity data for "PROTAC BRD9-binding moiety 1" and a known control inhibitor against BRD9, as determined by the TR-FRET assay. These values are for illustrative purposes.

Detailed Experimental Protocol

Materials and Reagents

Component	Supplier	Catalog #	Final Concentration/Reaction
BRD9, GST-tag	BPS Bioscience	31091	3 ng/reaction (e.g., 1.5 nM)
Terbium anti-GST Antibody (Donor)	BPS Bioscience	(in kit)	Varies by lot (e.g., 2 nM)
Dye-labeled Acceptor	BPS Bioscience	(in kit)	Varies by lot (e.g., 5 nM)
BET Bromodomain Ligand (Biotinylated)	BPS Bioscience	33000	Varies by lot (e.g., 10 nM)
3x BRD TR-FRET Assay Buffer 1	BPS Bioscience	33012	1x
"PROTAC BRD9-binding moiety 1"	User-provided	-	Variable (serial dilution)
Control Inhibitor (e.g., BI-9564)	User-provided	-	Variable (serial dilution)
White, low-volume 384-well plate	Corning	3824	1 plate
DMSO	Sigma-Aldrich	D2650	≤ 0.5% final concentration

Table 2: List of required materials and reagents for the BRD9 TR-FRET assay.

Experimental Workflow

The following diagram outlines the key steps in the experimental protocol.

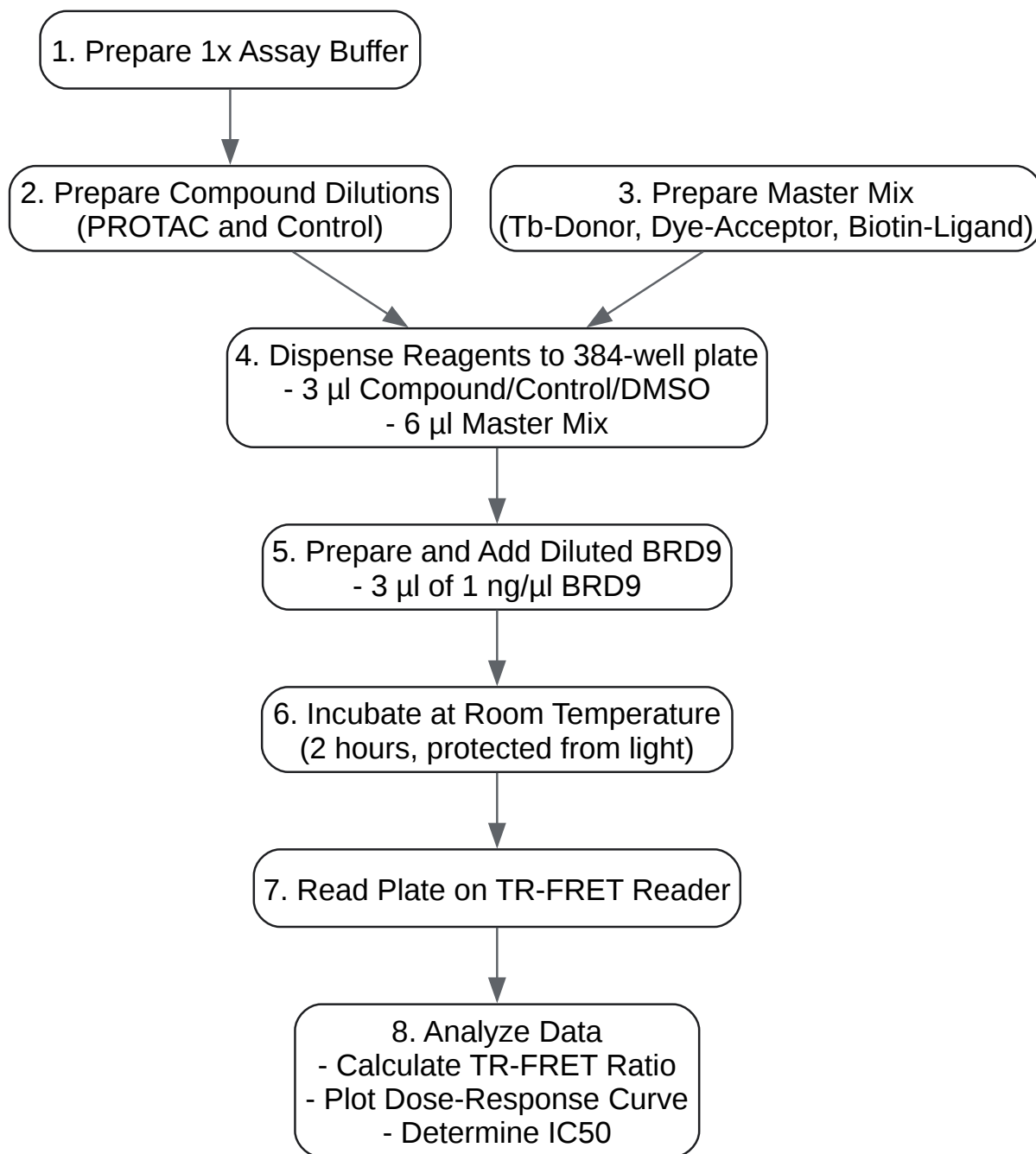

[Click to download full resolution via product page](#)

Figure 2: Step-by-step experimental workflow for the BRD9 TR-FRET assay.

Step-by-Step Procedure

1. Reagent Preparation: a. Prepare 1x BRD TR-FRET Assay Buffer by diluting the 3x stock with nuclease-free water. b. Thaw all protein and antibody components on ice. Keep on ice until use. Note: BRD9 is sensitive to freeze-thaw cycles; aliquot upon first use.[6]
2. Compound Dilution: a. Prepare a serial dilution of "**PROTAC BRD9-binding moiety 1**" and the control inhibitor in 1x Assay Buffer containing 0.5% DMSO. A typical starting concentration for the highest dose might be 100 μ M, followed by 10-point, 1:3 serial dilutions. b. For control wells, prepare a solution of 1x Assay Buffer with 0.5% DMSO (for "Positive Control" - 100% activity) and a high concentration of a known inhibitor (for "Negative Control" - 0% activity).
3. Master Mix Preparation: a. Prepare a master mix containing the Terbium-labeled anti-GST antibody, the Dye-labeled acceptor, and the biotinylated BET Bromodomain Ligand in 1x Assay Buffer. The final concentrations should be optimized, but starting points can be found in the manufacturer's datasheet.
4. Plate Dispensing: a. Add 3 μ l of the diluted test compounds, control inhibitor, or DMSO controls to the appropriate wells of a white, low-volume 384-well plate. b. Add 6 μ l of the Master Mix to all wells.
5. Reaction Initiation: a. Dilute the GST-BRD9 protein to a concentration of 1 ng/ μ l in 1x Assay Buffer.[6] b. Initiate the reaction by adding 3 μ l of the diluted GST-BRD9 to each well. The total reaction volume will be 12 μ l. c. Note: Discard any remaining diluted BRD9 protein after use.[6]
6. Incubation: a. Seal the plate and incubate at room temperature for 120 minutes, protected from light.[6]
7. Plate Reading: a. Read the plate on a microplate reader capable of TR-FRET measurements. b. Set the reader to perform two sequential measurements: i. Donor Emission: Excitation at ~340 nm, Emission at ~620 nm.[6] ii. Acceptor Emission: Excitation at ~340 nm, Emission at ~665 nm.[6] c. Instrument settings such as lag time (e.g., 60 μ s) and integration time (e.g., 500 μ s) should be optimized for the specific reader.[6]

Data Analysis

- Calculate the TR-FRET Ratio: For each well, calculate the ratio of the acceptor signal to the donor signal: Ratio = (Emission at 665 nm / Emission at 620 nm) * 10,000[6]

- **Normalize Data:** Calculate the percentage of inhibition for each test compound concentration using the following formula: $\% \text{ Inhibition} = 100 * (1 - [(FRET_sample - FRET_neg) / (FRET_pos - FRET_neg)])$ Where:
 - FRET_sample is the ratio from the test well.
 - FRET_neg is the ratio from the negative control (high inhibitor concentration).
 - FRET_pos is the ratio from the positive control (DMSO only).
- **Generate IC50 Curve:** a. Plot the % Inhibition against the logarithm of the test compound concentration. b. Fit the data using a non-linear regression model (e.g., four-parameter variable slope) to determine the IC50 value.

This protocol provides a robust framework for quantifying the binding of "**PROTAC BRD9-binding moiety 1**" to BRD9. Optimization of reagent concentrations and incubation times may be necessary to achieve the best assay window and performance.^{[1][8]}

References

- [1. General Stepwise Approach to Optimize a TR-FRET Assay for Characterizing the BRD/PROTAC/CRBN Ternary Complex - PMC \[pmc.ncbi.nlm.nih.gov\]](#)
- [2. General Stepwise Approach to Optimize a TR-FRET Assay for Characterizing the BRD/PROTAC/CRBN Ternary Complex - PubMed \[pubmed.ncbi.nlm.nih.gov\]](#)
- [3. pdfs.semanticscholar.org \[pdfs.semanticscholar.org\]](#)
- [4. biorxiv.org \[biorxiv.org\]](#)
- [5. Discovery of a Highly Potent and Selective BRD9 PROTAC Degradere Based on E3 Binder Investigation for the Treatment of Hematological Tumors - PubMed \[pubmed.ncbi.nlm.nih.gov\]](#)
- [6. bpsbioscience.com \[bpsbioscience.com\]](#)
- [7. bpsbioscience.com \[bpsbioscience.com\]](#)
- [8. researchgate.net \[researchgate.net\]](#)
- To cite this document: BenchChem. [Application Note: TR-FRET Assay for Characterizing "PROTAC BRD9-binding moiety 1"]. BenchChem, [2026]. [Online PDF]. Available at:

[<https://www.benchchem.com/product/b12423611/docs#application-note-tr-fret-assay-for-characterizing-protac-brd9-binding-moiety-1>]

Disclaimer & Data Validity:

The information provided in this document is for Research Use Only (RUO) and is strictly not intended for diagnostic or therapeutic procedures. While BenchChem strives to provide accurate protocols, we make no warranties, express or implied, regarding the fitness of this product for every specific experimental setup.

Technical Support: The protocols provided are for reference purposes. Unsure if this reagent suits your experiment?

Need Industrial/Bulk Grade? [Request Custom Synthesis Quote](#)

BenchChem

Our mission is to be the trusted global source of essential and advanced chemicals, empowering scientists and researchers to drive progress in science and industry.

Contact

Address: 3281 E Guasti Rd
Ontario, CA 91761, United States
Phone: (601) 213-4426
Email: info@benchchem.com

[Contact our Ph.D. Support Team for a compatibility check](#)