

# potential off-target effects of CP-628006 in experiments

**Author:** BenchChem Technical Support Team. **Date:** April 2026

## Compound of Interest

Compound Name: CP-628006

Cat. No.: B12422454

[Get Quote](#)

## Technical Support Center: CP-628006

This technical support center provides troubleshooting guidance and frequently asked questions (FAQs) for researchers, scientists, and drug development professionals using **CP-628006** in their experiments.

## Troubleshooting Guides

Issue	Possible Cause	Suggested Solution
Inconsistent or lower-than-expected potentiation of G551D-CFTR activity.	CP-628006's potentiation of G551D-CFTR is ATP-dependent.[1][2]	Ensure that the intracellular solution in your experimental setup (e.g., excised inside-out membrane patches) contains an adequate and consistent concentration of ATP (e.g., 1 mM).[3]
Variability in F508del-CFTR potentiation results.	The rescue of F508del-CFTR to the plasma membrane can be variable. CP-628006 acts as a potentiator on channels already at the membrane.	Use a standardized protocol for temperature-rescue of F508del-CFTR expressing cells to ensure consistent surface expression prior to applying CP-628006.[2]
Unexpected changes in cellular bioenergetics or mitochondrial function.	While not specifically documented for CP-628006, some small molecule CFTR modulators have been shown to have off-target effects on mitochondrial function.	Consider including control experiments to assess mitochondrial respiration (e.g., Seahorse assay) or membrane potential when observing unexpected global cellular effects.
Observed effects on other ion channels.	Although direct off-target effects of CP-628006 on other ion channels are not reported, some CFTR inhibitors are known to affect other channels like Orai1 and ENaC.[4][5]	To confirm the observed effect is CFTR-specific, use a CFTR-null cell line as a negative control. Additionally, consider using specific inhibitors for other suspected channels to dissect the observed phenotype.

## Frequently Asked Questions (FAQs)

What is the primary mechanism of action of **CP-628006**?

**CP-628006** is a cystic fibrosis transmembrane conductance regulator (CFTR) potentiator. It directly interacts with the CFTR protein at the plasma membrane to increase the channel's open probability, thereby enhancing the transport of chloride ions.[1] It achieves this by increasing the frequency and duration of channel openings.[1][2]

How does **CP-628006** differ from ivacaftor?

**CP-628006** has a distinct chemical structure and a different mechanism of CFTR potentiation compared to ivacaftor.[1][2][6] Key differences include:

- **ATP-Dependence:** The potentiation of G551D-CFTR by **CP-628006** is ATP-dependent, whereas ivacaftor's action is ATP-independent.[1][2]
- **Potency and Efficacy:** **CP-628006** generally exhibits lower potency and efficacy compared to ivacaftor.[1][2]
- **Effect on F508del-CFTR Deactivation:** **CP-628006** delays the deactivation of F508del-CFTR, while ivacaftor accentuates it.[1]

What are the known off-target effects of **CP-628006**?

Currently, there is no publicly available kinase profile or specific data on off-target binding of **CP-628006** to other proteins. The concept of "off-target effects" for CFTR modulators can also refer to unintended physiological consequences. For the broader class of CFTR modulators, some neuropsychiatric adverse effects have been reported, potentially linked to the modulation of CFTR and chloride transport in the brain.[7][8]

Can **CP-628006** be used in combination with other CFTR modulators?

Yes, studies have shown that for G551D-CFTR, the combined action of **CP-628006** and ivacaftor is greater than ivacaftor alone.[1] This suggests that the emergence of CFTR potentiators with diverse mechanisms of action, like **CP-628006**, opens up possibilities for combination therapies.[1][2]

## Quantitative Data Summary

Table 1: Potency (EC50) of **CP-628006** on F508del-CFTR

Compound	EC50 ( $\mu\text{M}$ )	Maximal Response (relative to Ivacaftor)
CP-628006	0.4	~50%

Data from studies on low temperature-rescued F508del-CFTR.[2]

## Experimental Protocols

Protocol: Assessing CFTR Potentiation using Ussing Chamber Electrophysiology

This protocol is designed to measure the effect of **CP-628006** on CFTR-mediated chloride secretion in primary human bronchial epithelial (hBE) cells cultured on permeable supports.

- Cell Culture: Culture primary hBE cells on permeable supports until a differentiated, polarized monolayer is formed.
- Ussing Chamber Setup: Mount the permeable supports in an Ussing chamber system. Bathe the apical and basolateral sides with appropriate physiological solutions and maintain at 37°C.
- Baseline Measurement: Measure the baseline short-circuit current (I<sub>sc</sub>) to assess the basal ion transport.
- Amiloride Application: Add amiloride to the apical solution to block the epithelial sodium channel (ENaC) and isolate CFTR-dependent chloride secretion.
- CFTR Activation: Add a CFTR agonist, such as forskolin, to the basolateral solution to activate CFTR through PKA-dependent phosphorylation.
- **CP-628006** Application: Add **CP-628006** in a dose-response manner to the apical solution and record the change in I<sub>sc</sub>.
- Maximal Potentiation: Add a saturating concentration of a potent potentiator like ivacaftor to determine the maximal CFTR activity.

- Data Analysis: Calculate the increase in Isc following the addition of **CP-628006** as a measure of its potentiator activity.

## Visualizations

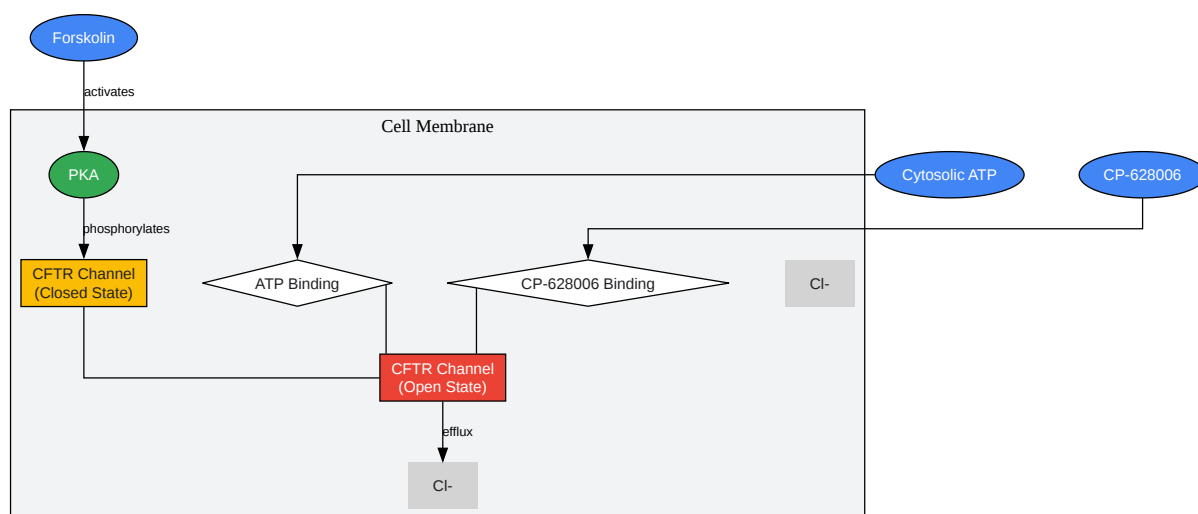

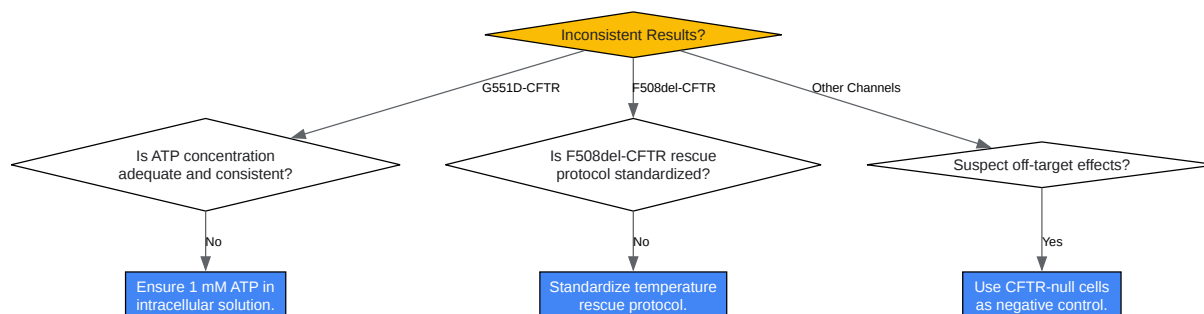

[Click to download full resolution via product page](#)

### Need Custom Synthesis?

BenchChem offers custom synthesis for rare earth carbides and specific isotopic labeling.

Email: [info@benchchem.com](mailto:info@benchchem.com) or [Request Quote Online](#).

## References

- [1. A small molecule CFTR potentiator restores ATP-dependent channel gating to the cystic fibrosis mutant G551D-CFTR - PubMed \[pubmed.ncbi.nlm.nih.gov\]](#)
- [2. A small molecule CFTR potentiator restores ATP-dependent channel gating to the cystic fibrosis mutant G551D-CFTR - PMC \[pmc.ncbi.nlm.nih.gov\]](#)
- [3. researchgate.net \[researchgate.net\]](#)
- [4. Pharmacological inhibitors of the cystic fibrosis transmembrane conductance regulator exert off-target effects on epithelial cation channels - PMC \[pmc.ncbi.nlm.nih.gov\]](#)
- [5. Pharmacological inhibitors of the cystic fibrosis transmembrane conductance regulator exert off-target effects on epithelial cation channels - PubMed \[pubmed.ncbi.nlm.nih.gov\]](#)
- [6. drughunter.com \[drughunter.com\]](#)

- [7. Neuropsychiatric adverse effects from CFTR modulators deserve a serious research effort - PubMed \[pubmed.ncbi.nlm.nih.gov\]](#)
- [8. Neuropsychiatric adverse effects from CFTR modulators deserve a serious research effort - PMC \[pmc.ncbi.nlm.nih.gov\]](#)
- To cite this document: BenchChem. [potential off-target effects of CP-628006 in experiments]. BenchChem, [2026]. [Online PDF]. Available at: [\[https://www.benchchem.com/product/b12422454/docs#potential-off-target-effects-of-cp-628006-in-experiments\]](https://www.benchchem.com/product/b12422454/docs#potential-off-target-effects-of-cp-628006-in-experiments)

---

### Disclaimer & Data Validity:

The information provided in this document is for Research Use Only (RUO) and is strictly not intended for diagnostic or therapeutic procedures. While BenchChem strives to provide accurate protocols, we make no warranties, express or implied, regarding the fitness of this product for every specific experimental setup.

**Technical Support:** The protocols provided are for reference purposes. Unsure if this reagent suits your experiment?

**Need Industrial/Bulk Grade?** [Request Custom Synthesis Quote](#)

## BenchChem

Our mission is to be the trusted global source of essential and advanced chemicals, empowering scientists and researchers to drive progress in science and industry.

### Contact

Address: 3281 E Guasti Rd  
Ontario, CA 91761, United States  
Phone: (601) 213-4426  
Email: [info@benchchem.com](mailto:info@benchchem.com)

[Contact our Ph.D. Support Team for a compatibility check](#)

