

# Unveiling T-Cell Responses: A Comparative Analysis of Influenza Virus Epitopes

**Author:** BenchChem Technical Support Team. **Date:** April 2026

## Compound of Interest

Compound Name: *Influenza HA (518-526)*

Cat. No.: *B12422881*

[Get Quote](#)

For researchers, scientists, and drug development professionals, understanding the nuances of T-cell responses to various viral components is paramount in the quest for more effective and broadly protective influenza vaccines. This guide provides a detailed comparison of T-cell responses directed against the hemagglutinin (HA) epitope 518-526 and other key immunodominant epitopes of the influenza virus, supported by experimental data and detailed methodologies.

Influenza A virus presents a significant global health challenge due to its seasonal epidemics and pandemic potential. While antibodies targeting the viral surface glycoprotein hemagglutinin (HA) are a primary focus of current vaccines, T-cell immunity plays a crucial role in viral clearance and protection against diverse influenza strains. T-cells recognize short, linear peptide fragments of viral proteins, known as epitopes, presented on the surface of infected cells. The internal proteins of the influenza virus, such as Nucleoprotein (NP) and Matrix protein 1 (M1), are more conserved across different strains than the surface glycoproteins, making their epitopes attractive targets for universal vaccine strategies.

This guide focuses on a comparative analysis of the T-cell response to the HA (518-526) epitope against other well-characterized and often immunodominant epitopes from the NP and M1 proteins.

## Comparative Analysis of T-Cell Responses

Experimental data consistently demonstrates that T-cell responses to influenza virus are characterized by an immunodominance hierarchy, where responses to certain epitopes are more robust than others. While HA is a major target for antibodies, the internal proteins NP and M1 are frequently the primary targets for CD8+ T-cell responses.

The following table summarizes quantitative data from a study comparing the magnitude of CD8+ T-cell responses to the HA (518-526) and NP (147-155) epitopes in BALB/c mice after vaccination. The response was measured by an Interferon-gamma (IFN- $\gamma$ ) ELISpot assay, which quantifies the number of antigen-specific T-cells based on their cytokine secretion.

Epitope	Protein Origin	T-Cell Response (SFU/10 <sup>6</sup> splenocytes)
HA (518-526)	Hemagglutinin	~150
NP (147-155)	Nucleoprotein	~400

SFU: Spot Forming Units. Data is approximated from graphical representations in the cited literature for comparative purposes.

As the data indicates, the T-cell response to the NP (147-155) epitope was significantly higher than the response to the HA (518-526) epitope, highlighting the immunodominance of this internal protein epitope in this experimental model.<sup>[1]</sup> This finding aligns with a broader body of research suggesting that conserved internal proteins are major targets of the cellular immune response to influenza.

## Experimental Methodologies

To facilitate the replication and further investigation of these findings, detailed protocols for the key experimental assays are provided below.

### Interferon-gamma (IFN- $\gamma$ ) ELISpot Assay

The ELISpot assay is a highly sensitive method for quantifying the frequency of cytokine-secreting cells at the single-cell level.

**Principle:** The assay captures secreted IFN- $\gamma$  from activated T-cells onto a membrane coated with a specific anti-IFN- $\gamma$  antibody. The captured cytokine is then detected by a second, biotinylated anti-IFN- $\gamma$  antibody and a streptavidin-enzyme conjugate, resulting in a visible spot for each cytokine-producing cell.

**Protocol:**

- **Plate Coating:** A 96-well ELISpot plate is coated with a capture anti-IFN- $\gamma$  antibody and incubated overnight at 4°C.
- **Cell Preparation:** Splenocytes are isolated from immunized or infected animals and resuspended in complete RPMI medium.
- **Cell Stimulation:** The cells are added to the coated plate along with the specific peptide epitope (e.g., HA (518-526) or NP (147-155)) at a predetermined concentration. A positive control (e.g., PMA/Ionomycin) and a negative control (medium alone) are included.
- **Incubation:** The plate is incubated for 18-24 hours at 37°C in a 5% CO<sub>2</sub> incubator to allow for T-cell activation and cytokine secretion.
- **Detection:** After incubation, the cells are washed away, and a biotinylated detection anti-IFN- $\gamma$  antibody is added.
- **Enzyme Conjugation:** Following another wash, a streptavidin-alkaline phosphatase (ALP) or horseradish peroxidase (HRP) conjugate is added.
- **Substrate Addition:** After a final wash, a substrate solution is added, which is converted by the enzyme to form a colored precipitate at the site of cytokine secretion.
- **Spot Analysis:** The resulting spots are counted using an automated ELISpot reader. The number of spots corresponds to the number of IFN- $\gamma$  secreting cells.

## Intracellular Cytokine Staining (ICS)

ICS is a flow cytometry-based assay that allows for the simultaneous identification of cell surface markers and intracellular cytokines, providing a multiparametric analysis of antigen-specific T-cell responses.

Principle: Cells are stimulated with the antigen of interest in the presence of a protein transport inhibitor, which causes cytokines to accumulate within the cell. The cells are then stained for surface markers, fixed, permeabilized, and stained for intracellular cytokines with fluorescently labeled antibodies.

Protocol:

- **Cell Stimulation:** Splenocytes are stimulated with the specific peptide epitope for several hours in the presence of a protein transport inhibitor (e.g., Brefeldin A or Monensin).
- **Surface Staining:** Cells are washed and stained with fluorescently labeled antibodies against cell surface markers (e.g., CD3, CD8, CD4).
- **Fixation and Permeabilization:** The cells are then fixed to preserve their cellular structure and permeabilized to allow antibodies to enter the cell.
- **Intracellular Staining:** Fluorescently labeled antibodies against intracellular cytokines (e.g., IFN- $\gamma$ , TNF- $\alpha$ , IL-2) are added to the permeabilized cells.
- **Flow Cytometry Analysis:** The stained cells are analyzed on a flow cytometer. By gating on specific cell populations (e.g., CD8+ T-cells), the percentage of cells producing a particular cytokine in response to the specific epitope can be determined.

## Visualizing the Experimental Workflow

To provide a clear overview of the process for evaluating T-cell responses, the following diagram illustrates a typical experimental workflow.

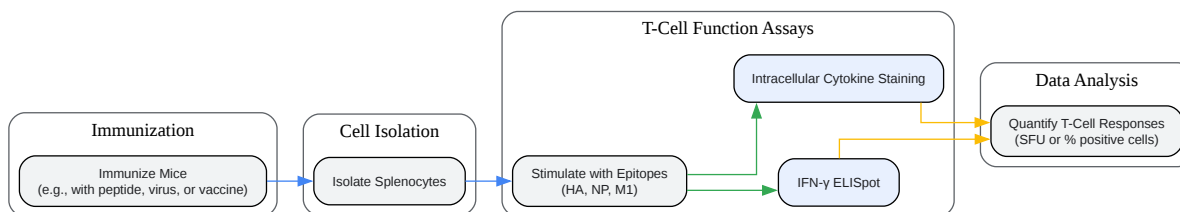

[Click to download full resolution via product page](#)

Caption: Experimental workflow for comparing T-cell responses to influenza epitopes.

## Signaling Pathways in T-Cell Activation

The activation of a CD8<sup>+</sup> T-cell by an antigen-presenting cell (APC) involves a complex signaling cascade initiated by the interaction of the T-cell receptor (TCR) with the peptide-MHC I complex.

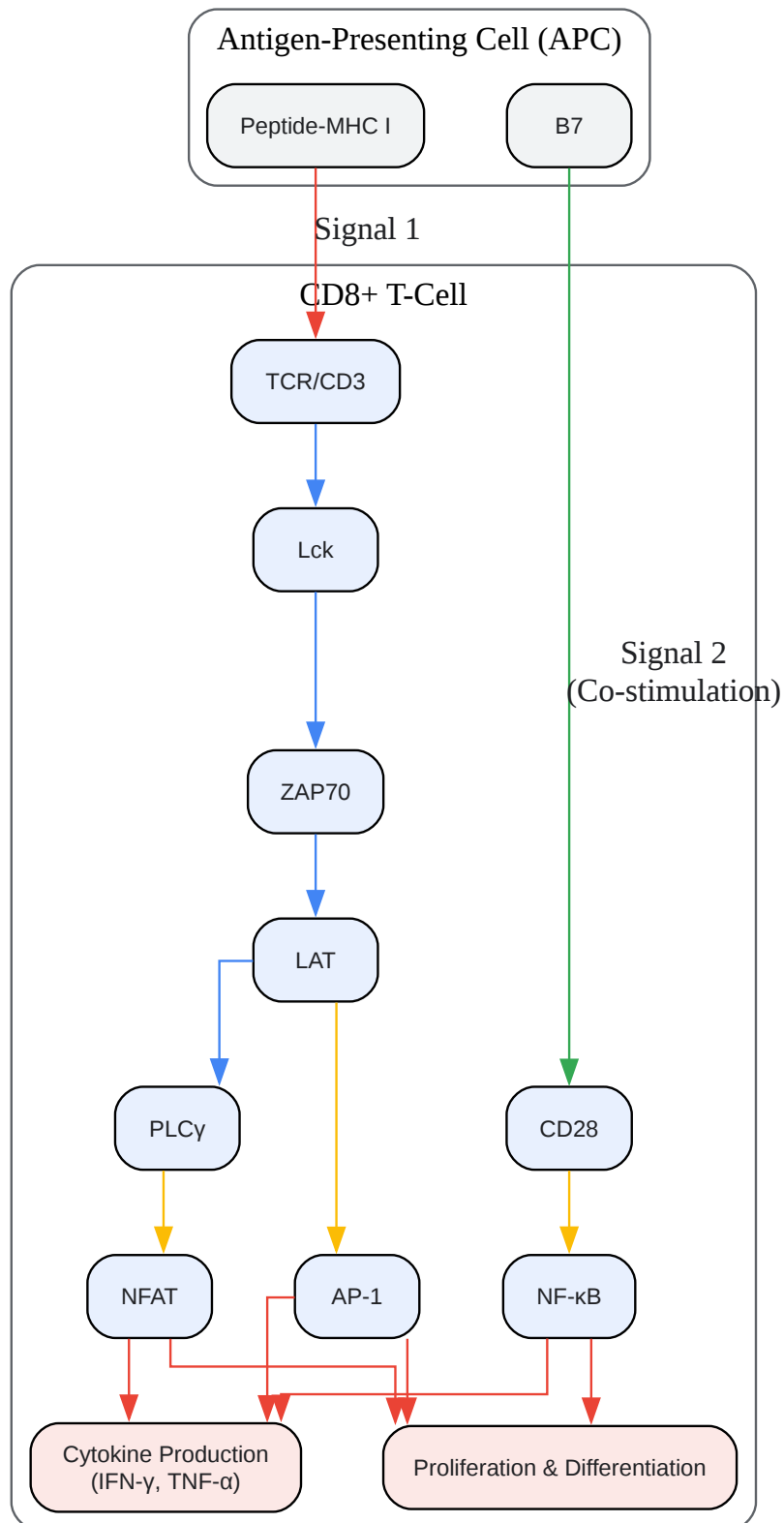

[Click to download full resolution via product page](#)

Caption: Simplified signaling pathway of CD8+ T-cell activation.

In conclusion, while the HA (518-526) epitope can elicit a measurable T-cell response, epitopes derived from conserved internal proteins like NP and M1 are often immunodominant. This observation has significant implications for the design of next-generation influenza vaccines that aim to induce broad and long-lasting T-cell immunity. The experimental protocols and workflows provided in this guide offer a foundation for researchers to further explore and compare the immunogenicity of various influenza epitopes.

### Need Custom Synthesis?

BenchChem offers custom synthesis for rare earth carbides and specific isotopic labeling.

Email: [info@benchchem.com](mailto:info@benchchem.com) or [Request Quote Online](#).

## References

- [1. researchgate.net \[researchgate.net\]](https://www.researchgate.net)
- To cite this document: BenchChem. [Unveiling T-Cell Responses: A Comparative Analysis of Influenza Virus Epitopes]. BenchChem, [2026]. [Online PDF]. Available at: [\[https://www.benchchem.com/product/b12422881/docs#unveiling-t-cell-responses-a-comparative-analysis-of-influenza-virus-epitopes\]](https://www.benchchem.com/product/b12422881/docs#unveiling-t-cell-responses-a-comparative-analysis-of-influenza-virus-epitopes)

---

### Disclaimer & Data Validity:

The information provided in this document is for Research Use Only (RUO) and is strictly not intended for diagnostic or therapeutic procedures. While BenchChem strives to provide accurate protocols, we make no warranties, express or implied, regarding the fitness of this product for every specific experimental setup.

**Technical Support:** The protocols provided are for reference purposes. Unsure if this reagent suits your experiment?

**Need Industrial/Bulk Grade?** [Request Custom Synthesis Quote](#)

# BenchChem

Our mission is to be the trusted global source of essential and advanced chemicals, empowering scientists and researchers to drive progress in science and industry.

## Contact

Address: 3281 E Guasti Rd

Ontario, CA 91761, United States

Phone: (601) 213-4426

Email: [info@benchchem.com](mailto:info@benchchem.com)

[Contact our Ph.D. Support Team for a compatibility check](#)