

Technical Support Center: Ensuring Reproducibility in CP-628006 Functional Assays

Author: BenchChem Technical Support Team. **Date:** April 2026

Compound of Interest

Compound Name: CP-628006

Cat. No.: B12422454

[Get Quote](#)

This technical support center provides troubleshooting guidance and frequently asked questions (FAQs) to assist researchers, scientists, and drug development professionals in achieving reproducible results in functional assays involving the CFTR potentiator, **CP-628006**.

Frequently Asked Questions (FAQs)

Q1: What is **CP-628006** and what is its mechanism of action?

CP-628006 is a novel, small-molecule potentiator of the Cystic Fibrosis Transmembrane Conductance Regulator (CFTR) protein.[1][2] It directly interacts with the CFTR chloride channel at the plasma membrane to enhance its gating, meaning it increases the frequency and duration of channel openings.[1] This leads to an overall increase in chloride ion transport. Notably, its mechanism differs from the well-characterized potentiator ivacaftor, particularly in its effects on certain CFTR mutants.[1]

Q2: For which CFTR mutations is **CP-628006** most effective?

Studies have shown that **CP-628006** potentiates wild-type, F508del-CFTR, and G551D-CFTR.[1] Its effects on the F508del-CFTR variant have been observed to be larger than those on the G551D-CFTR gating variant.[1]

Q3: How does the potency and efficacy of **CP-628006** compare to ivacaftor?

The potency and efficacy of **CP-628006** are reported to be lower than those of ivacaftor.[1] This is a critical consideration for experimental design, as higher concentrations of **CP-628006** may be required to achieve a maximal response.

Q4: What is the significance of the ATP-dependence of **CP-628006**'s effect on G551D-CFTR?

A key differentiator for **CP-628006** is that its potentiation of the G551D-CFTR mutant is ATP-dependent, whereas ivacaftor's action is ATP-independent.[1] This suggests a distinct mechanism of action and has important implications for in vitro assays, particularly patch-clamp electrophysiology, where the intracellular ATP concentration must be carefully controlled. The G551D mutation typically abolishes ATP-dependent gating.[3][4][5]

Q5: How should I prepare and store **CP-628006**?

CP-628006 can be dissolved in dimethyl sulfoxide (DMSO) to create a stock solution. For storage, it is recommended to keep the powder at -20°C for up to two years. In DMSO, it can be stored at 4°C for up to two weeks or at -80°C for up to six months.

Troubleshooting Guides

Issue 1: Low or No Response to **CP-628006** in Electrophysiology Assays

Possible Causes & Solutions

| Possible Cause | Troubleshooting Steps |
|---|--|
| Suboptimal Compound Concentration | Due to its lower potency compared to ivacaftor, ensure you are using a sufficient concentration of CP-628006. Perform a dose-response curve to determine the optimal concentration for your specific cell type and CFTR mutant. |
| Compound Solubility Issues | Visually inspect your working solutions for any precipitation. If solubility is a concern, consider preparing fresh dilutions from a DMSO stock for each experiment. Ensure the final DMSO concentration in your assay is consistent across all conditions and does not exceed a level that affects cell health or channel function (typically <0.1%). |
| Inadequate Intracellular ATP (for G551D-CFTR) | When studying the G551D mutant, the ATP-dependence of CP-628006 is crucial. Ensure your patch-clamp intracellular solution contains an adequate and consistent concentration of ATP (typically 1-5 mM).[6][7] Prepare fresh ATP-containing solutions for each experiment, as ATP can degrade over time. |
| Cell Health and Expression Levels | Poor cell health or low CFTR expression can lead to weak responses. Ensure cells are healthy, not overgrown, and that CFTR expression is adequate. For stable cell lines, periodically verify expression levels. |
| Incorrect Recording Solutions | Verify the composition and pH of your intracellular and extracellular recording solutions. For Ussing chamber experiments, ensure the appropriate chloride gradient is used. |

Issue 2: High Variability Between Experiments

Possible Causes & Solutions

| Possible Cause | Troubleshooting Steps |
|---------------------------------------|---|
| Inconsistent Cell Culture Conditions | Maintain consistent cell passage numbers, seeding densities, and culture durations. Variations in these parameters can lead to differences in CFTR expression and overall cell physiology. |
| Variability in Compound Addition | Ensure precise and consistent timing and method of compound addition to your experimental setup. Use calibrated pipettes and ensure thorough but gentle mixing. |
| Temperature Fluctuations | CFTR channel function can be sensitive to temperature. Maintain a consistent temperature throughout your experiments. For patch-clamp, monitor the temperature of the recording chamber. |
| Run-down of CFTR Activity | CFTR channel activity can "run-down" over the course of an experiment, especially in excised patch-clamp recordings. To minimize this, include PKA and ATP in your intracellular solutions.[6] Plan your experiments to have a consistent duration from patch excision to data recording. |
| Inconsistent Data Analysis Parameters | Use standardized criteria for data analysis. Define clear parameters for baseline selection, peak measurement, and statistical analysis to ensure consistency across different experiments. |

Experimental Protocols

Patch-Clamp Electrophysiology (Whole-Cell & Inside-Out Patch)

This protocol provides a general framework. Specific voltages and solution compositions may need to be optimized for your experimental system.

1. Cell Preparation:

- Plate CFTR-expressing cells (e.g., HEK293, CHO) on glass coverslips 24-48 hours before the experiment.
- For temperature-sensitive mutants like F508del, an incubation at a lower temperature (e.g., 27°C) for 24-48 hours prior to the experiment may be necessary to promote trafficking to the cell surface.

2. Solution Preparation:

| Solution Type | Composition |
|----------------------------------|---|
| Extracellular (Bath) Solution | 145 mM NaCl, 4.5 mM KCl, 1 mM MgCl ₂ , 2 mM CaCl ₂ , 5 mM HEPES, 10 mM Glucose (pH 7.4 with NaOH) |
| Intracellular (Pipette) Solution | 147 mM NMDG-Cl, 2 mM MgCl ₂ , 5 mM HEPES, 1 mM Mg-ATP, 75 nM PKA catalytic subunit (pH 7.2 with NMDG) |

Note on Intracellular Solution: For experiments specifically investigating the ATP-dependence of **CP-628006** on G551D-CFTR, it is critical to perform experiments with varying and controlled ATP concentrations. Always prepare ATP-containing solutions fresh.

3. Recording Procedure:

- Place the coverslip in the recording chamber and perfuse with extracellular solution.
- Form a giga-ohm seal with a borosilicate glass pipette (2-4 MΩ resistance).
- For whole-cell recordings, rupture the membrane to gain electrical access. For inside-out patch, excise the patch of membrane.
- Clamp the membrane potential at a holding potential of -50 mV.

- Establish a stable baseline recording.
- Perfuse the chamber with the extracellular solution containing **CP-628006** at the desired concentration.
- Record the change in current.
- After recording, perfuse with a washout solution to observe reversibility.

Ussing Chamber Assay

1. Cell Culture on Permeable Supports:

- Seed CFTR-expressing epithelial cells (e.g., FRT, hBE) on permeable filter supports (e.g., Transwells®).
- Culture the cells until a confluent and polarized monolayer is formed, as indicated by a stable transepithelial electrical resistance (TEER).

2. Ussing Chamber Setup:

- Mount the permeable support in the Ussing chamber, separating the apical and basolateral chambers.
- Fill both chambers with pre-warmed (37°C) and gassed (95% O₂/5% CO₂) Krebs-Bicarbonate Ringer (KBR) solution.

3. Short-Circuit Current (I_{sc}) Measurement:

- Clamp the transepithelial voltage to 0 mV and measure the I_{sc}.
- Allow the baseline I_{sc} to stabilize.
- Sequentially add the following drugs to the apical or basolateral chambers as indicated:
 - Amiloride (apical): To inhibit the epithelial sodium channel (ENaC).
 - Forskolin (apical and basolateral): To activate adenylyl cyclase, increase intracellular cAMP, and activate CFTR.

- **CP-628006** (apical): To potentiate CFTR-mediated chloride current.
- CFTRinh-172 (apical): To inhibit the CFTR-dependent current.
- Record the change in I_{sc} after each addition.

Visualizations

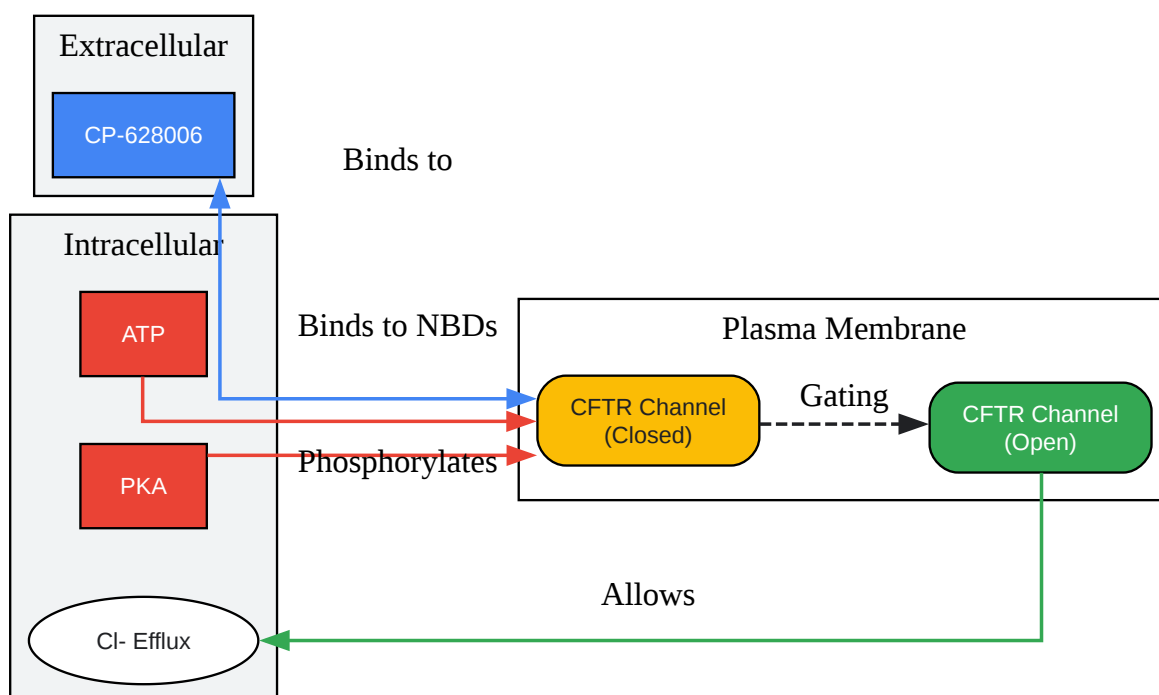

[Click to download full resolution via product page](#)

Caption: Signaling pathway of **CP-628006** action on the CFTR channel.

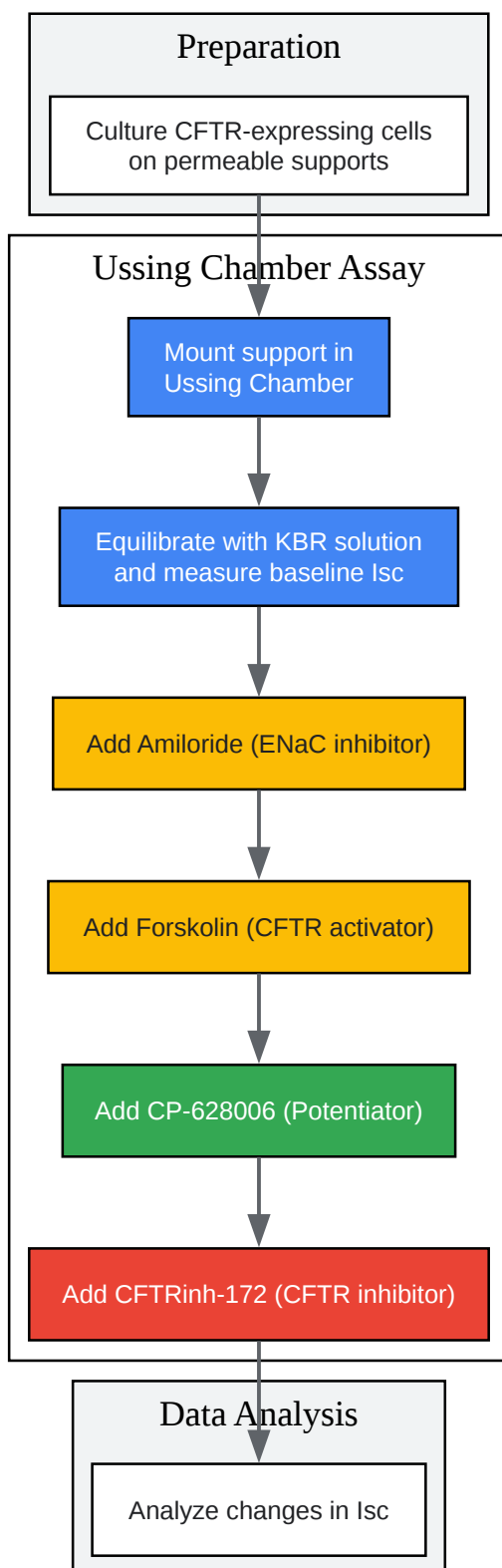

[Click to download full resolution via product page](#)

Caption: Experimental workflow for a Ussing chamber assay with **CP-628006**.

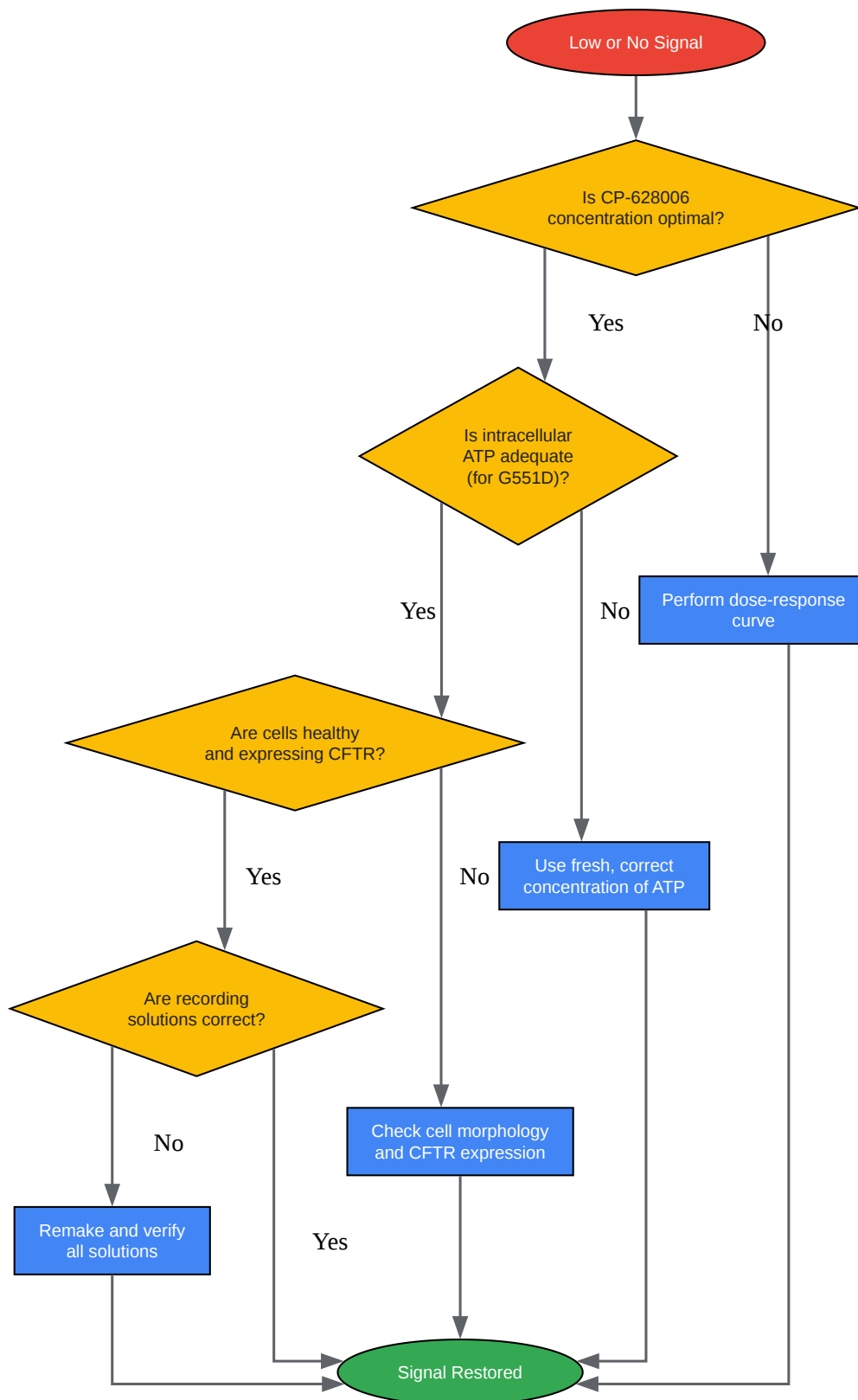

[Click to download full resolution via product page](#)

Caption: Troubleshooting logic for low or no signal in **CP-628006** assays.

Need Custom Synthesis?

BenchChem offers custom synthesis for rare earth carbides and specific isotopic labeling.

Email: info@benchchem.com or [Request Quote Online](#).

References

- 1. A small molecule CFTR potentiator restores ATP-dependent channel gating to the cystic fibrosis mutant G551D-CFTR - PubMed [pubmed.ncbi.nlm.nih.gov]
- 2. [medchemexpress.com](https://www.medchemexpress.com) [[medchemexpress.com](https://www.medchemexpress.com)]
- 3. G551D and G1349D, Two CF-associated Mutations in the Signature Sequences of CFTR, Exhibit Distinct Gating Defects - PMC [pubmed.ncbi.nlm.nih.gov]
- 4. Mechanism of G551D-CFTR (cystic fibrosis transmembrane conductance regulator) potentiation by a high affinity ATP analog - PubMed [pubmed.ncbi.nlm.nih.gov]
- 5. Breakthrough Therapies: Cystic Fibrosis (CF) Potentiators and Correctors - PMC [pubmed.ncbi.nlm.nih.gov]
- 6. A small molecule CFTR potentiator restores ATP-dependent channel gating to the cystic fibrosis mutant G551D-CFTR - PMC [pubmed.ncbi.nlm.nih.gov]
- 7. [re-place.be](https://www.re-place.be) [[re-place.be](https://www.re-place.be)]
- To cite this document: BenchChem. [Technical Support Center: Ensuring Reproducibility in CP-628006 Functional Assays]. BenchChem, [2026]. [Online PDF]. Available at: [<https://www.benchchem.com/product/b12422454/docs#technical-support-center-ensuring-reproducibility-in-cp-628006-functional-assays>]

Disclaimer & Data Validity:

The information provided in this document is for Research Use Only (RUO) and is strictly not intended for diagnostic or therapeutic procedures. While BenchChem strives to provide accurate protocols, we make no warranties, express or implied, regarding the fitness of this product for every specific experimental setup.

Technical Support: The protocols provided are for reference purposes. Unsure if this reagent suits your experiment?

Need Industrial/Bulk Grade? [Request Custom Synthesis Quote](#)

BenchChem

Our mission is to be the trusted global source of essential and advanced chemicals, empowering scientists and researchers to drive progress in science and industry.

Contact

Address: 3281 E Guasti Rd
Ontario, CA 91761, United States
Phone: (601) 213-4426
Email: info@benchchem.com

[Contact our Ph.D. Support Team for a compatibility check](#)