

# Introduction: The Intersection of the Ku Band and Electronic Warfare

**Author:** BenchChem Technical Support Team. **Date:** April 2026

## Compound of Interest

Compound Name: CMD178  
Cat. No.: B12422540

[Get Quote](#)

Electronic Warfare (EW) is a critical military capability that involves the use of the electromagnetic spectrum to control the operational environment, attack an adversary, and protect friendly forces.[1][2] It is broadly categorized into three divisions: Electronic Attack (EA), which involves using electromagnetic energy to disrupt or destroy enemy capabilities; Electronic Protection (EP), which focuses on safeguarding friendly forces from enemy EA; and Electronic Support (ES), which involves detecting, identifying, and locating sources of electromagnetic energy for threat recognition and targeting.[3]

The Ku band, a segment of the microwave frequency range from 12 to 18 GHz, is a pivotal part of the modern electromagnetic environment.[4][5] Its characteristics—such as enabling smaller antennas, supporting high-capacity data links, and its widespread use in satellite communications and radar systems—make it a focal point for EW operations.[6][7] From unmanned aerial vehicle (UAV) data links to satellite broadcasting and military fire-control radars, the Ku band is densely populated with signals that are of immense interest in a contested environment.[8][9]

At the heart of any system designed to operate within this frequency band for EW purposes is the RF mixer. A mixer is a nonlinear three-port device that converts a signal from one frequency to another, a process known as heterodyning.[10][11] This frequency conversion is a

fundamental requirement for nearly all advanced RF systems, making Ku band mixers indispensable components in modern EW technology.[11][12]

## The Fundamental Role of Frequency Mixers

An RF mixer combines two input signals—the Radio Frequency (RF) signal and a Local Oscillator (LO) signal—to produce an output signal at a new frequency, called the Intermediate Frequency (IF).[10] The IF signal contains both the sum and difference of the RF and LO frequencies ( $IF = |f_{RF} \pm f_{LO}|$ ).[10][13]

- **Downconversion:** In a receiver, the incoming high-frequency RF signal is mixed with an LO signal to produce a lower, fixed IF. This allows subsequent amplification, filtering, and digitization to be performed more effectively and efficiently than at the original RF frequency. [11]
- **Upconversion:** In a transmitter, a low-frequency IF signal containing information is mixed with a high-frequency LO signal to generate a high-frequency RF signal for transmission.[10]

In the context of electronic warfare, this frequency-shifting capability is the cornerstone of signal intelligence, jamming, and deception.

## Core Applications in Electronic Warfare Systems

Ku band mixers are integral to a wide array of EW systems, enabling them to receive, analyze, and transmit signals in this critical frequency range.

### Electronic Support (ES)

ES systems are designed to "listen" to the electromagnetic spectrum to provide situational awareness and identify threats.

- **Signal Intelligence (SIGINT) and Electronic Intelligence (ELINT):** In SIGINT/ELINT receivers, Ku band mixers are the first critical component in the signal chain. They downconvert a wide range of incoming Ku band signals from sources like satellite communications, data links, and radar systems.[14] This conversion to a lower IF allows for detailed analysis by digital signal processing (DSP) systems to classify and geolocate the signal source, providing critical intelligence.[2]

- **Radar Warning Receivers (RWR):** RWRs are defensive systems that detect and identify radar signals, alerting a platform (like an aircraft) that it is being targeted. When an enemy fire-control radar operating in the Ku band illuminates the platform, the RWR's Ku band mixer downconverts this signal for immediate analysis and identification, enabling the deployment of countermeasures.[15]

## Electronic Attack (EA)

EA systems actively transmit energy to disrupt or deceive enemy systems.

- **Jamming Systems:** To effectively jam an enemy Ku band radar or communication link, a high-power noise or deceptive signal must be transmitted at the exact same frequency. Ku band mixers are used in an upconverter configuration within the jamming system to translate a baseband or IF jamming signal to the target's Ku band operational frequency.[3][14]
- **Deception and Spoofing (DRFM):** Digital Radio Frequency Memory (DRFM) is a sophisticated EA technique where an enemy's radar pulse is received, stored digitally, manipulated, and then re-transmitted.[16] A Ku band mixer first downconverts the incoming radar pulse. The DRFM system then modifies its timing or frequency characteristics to create false targets or incorrect velocity information. A second Ku band mixer then upconverts this modified signal and transmits it back to the enemy radar, causing confusion and breaking the radar's lock.[16]

## Quantitative Data and Technical Specifications

The performance of a Ku band mixer in an EW application is defined by several key parameters. The suitability of a mixer for a specific role—whether in a sensitive ELINT receiver or a high-power jammer—depends on these specifications.

Parameter	Description	Typical Value for Ku Band EW Mixers	Importance in Electronic Warfare
RF/LO Frequency Range	The range of frequencies over which the mixer can operate.	RF: 12-18 GHz; LO: 12-18 GHz	Must cover the operational frequencies of threat systems (radars, communication links).
IF Frequency Range	The frequency range of the downconverted/upconverted signal.	DC - 6 GHz	Determines the bandwidth of the signal that can be processed by subsequent components.
Conversion Loss / Gain	The ratio of the IF output power to the RF input power. Passive mixers have loss; active mixers can have gain. <a href="#">[10]</a>	5 - 10 dB (Loss)	Lower conversion loss in receivers improves the overall noise figure and sensitivity, allowing detection of weaker signals.
Isolation	The amount of power leakage between ports (e.g., LO-to-RF, RF-to-IF). <a href="#">[10]</a>	25 - 40 dB	High isolation prevents the powerful LO signal from leaking and interfering with the sensitive RF input or other system components.
Noise Figure (NF)	A measure of the degradation in the signal-to-noise ratio caused by the mixer.	5 - 10 dB	A low noise figure is critical for ES receivers to detect faint signals from distant threats.
1 dB Compression Point (P1dB)	The input power level at which the	+5 to +15 dBm	A high P1dB is crucial for EW receivers

	conversion loss increases by 1 dB. It indicates the onset of nonlinearity.		operating in environments with strong interfering signals to avoid saturation.
Third-Order Intercept Point (IP3)	A measure of the mixer's linearity and ability to handle multiple signals without creating distortion.	+15 to +25 dBm	High IP3 is essential to prevent strong friendly or interfering signals from creating spurious signals that could be mistaken for threats.

## Experimental Protocols: Characterizing a Ku Band Mixer

Verifying the performance of a Ku band mixer for an EW application requires a rigorous and precise measurement methodology. The following protocol outlines the standard procedure for characterizing the key parameters.

**Objective:** To measure the conversion loss, isolation, and linearity (P1dB) of a Ku band mixer.

**Equipment:**

- Vector Network Analyzer (VNA) or two RF Signal Generators and a Spectrum Analyzer
- Power Meter
- DC Power Supply (for active mixers)
- Device Under Test (DUT): Ku band mixer

**Methodology:**

- Setup and Calibration:
  - Connect the test equipment as shown in the experimental setup diagram below.

- Allow all instruments to warm up for at least 30 minutes for stable operation.
- Perform a full two-port calibration on the VNA or a power calibration on the spectrum analyzer and cables to the measurement plane of the DUT.
- Conversion Loss Measurement:
  - Set Signal Generator 1 (LO) to the center frequency of the LO band (e.g., 14 GHz) at a specified power level (e.g., +13 dBm).
  - Set Signal Generator 2 (RF) to a frequency that will produce the desired IF (e.g., RF = 15 GHz for a 1 GHz IF). Set the RF power to a low level where the mixer is known to be linear (e.g., -10 dBm).
  - Measure the output power at the IF port using the Spectrum Analyzer.
  - Conversion Loss (dB) = Input RF Power (dBm) - Output IF Power (dBm).
  - Sweep the RF frequency across the 12-18 GHz band and record the conversion loss at each point to characterize its flatness.
- Isolation Measurement:
  - LO-to-RF Isolation: Turn off the RF signal generator. Measure the power leaking from the LO port to the RF port using the spectrum analyzer. Isolation (dB) = LO Power at LO Port (dBm) - Leaked LO Power at RF Port (dBm).
  - LO-to-IF Isolation: Measure the power leaking from the LO port to the IF port.
  - RF-to-IF Isolation: Turn off the LO signal generator. Measure the power leaking from the RF port to the IF port.
- 1 dB Compression Point (P1dB) Measurement:
  - Set the LO and RF frequencies as in the conversion loss measurement.
  - Start with a low RF input power (e.g., -20 dBm).

- Measure the IF output power and calculate the conversion loss.
- Increase the RF input power in 1 dB steps, recording the IF output power at each step.
- Plot the IF output power vs. the RF input power. The P1dB point is where the measured output power deviates from the ideal linear response by 1 dB.

## Visualizations: Workflows and Logical Diagrams

The following diagrams illustrate the logical role of Ku band mixers in EW systems and their characterization.

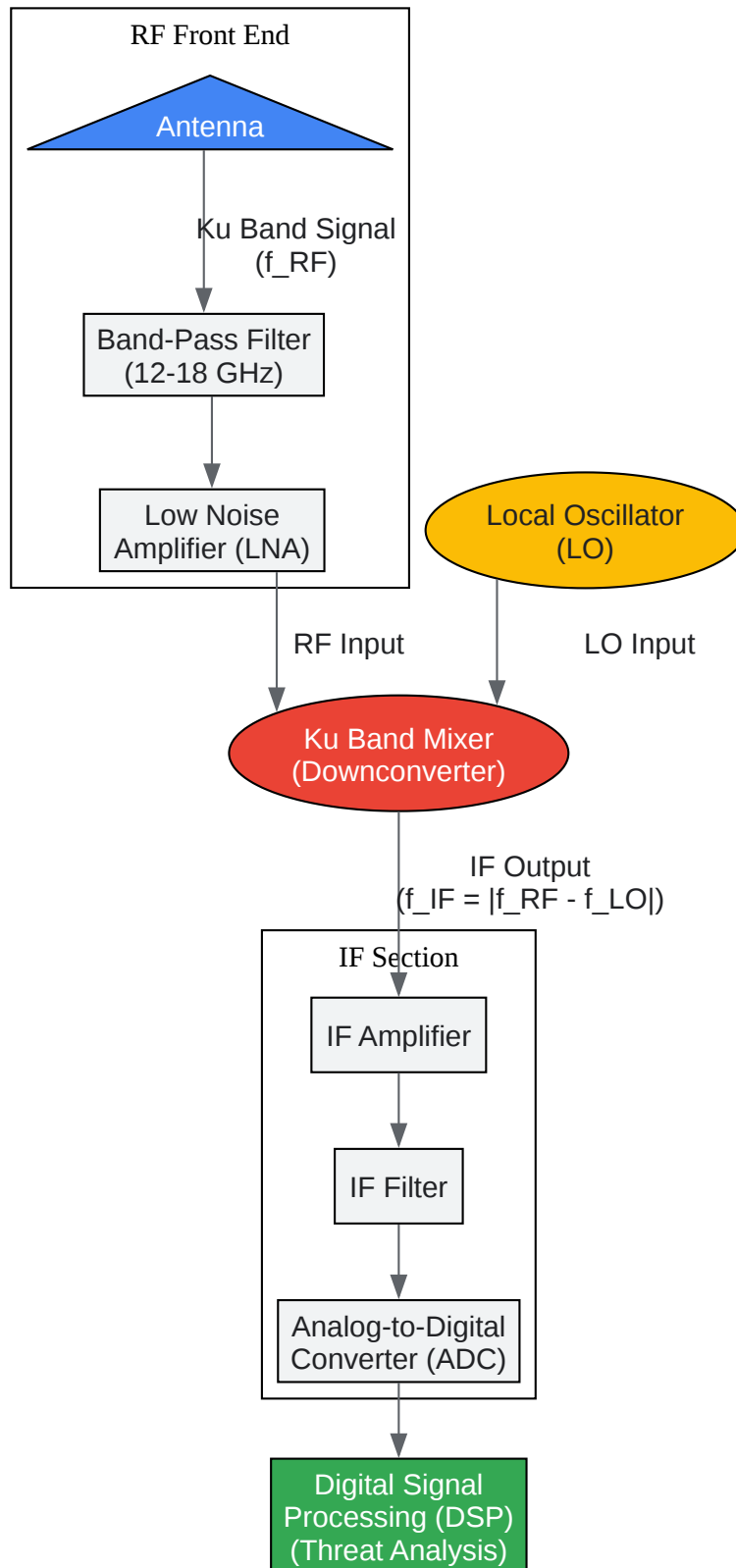

[Click to download full resolution via product page](#)

Caption: Signal processing flow in a typical Electronic Support (ES) receiver.

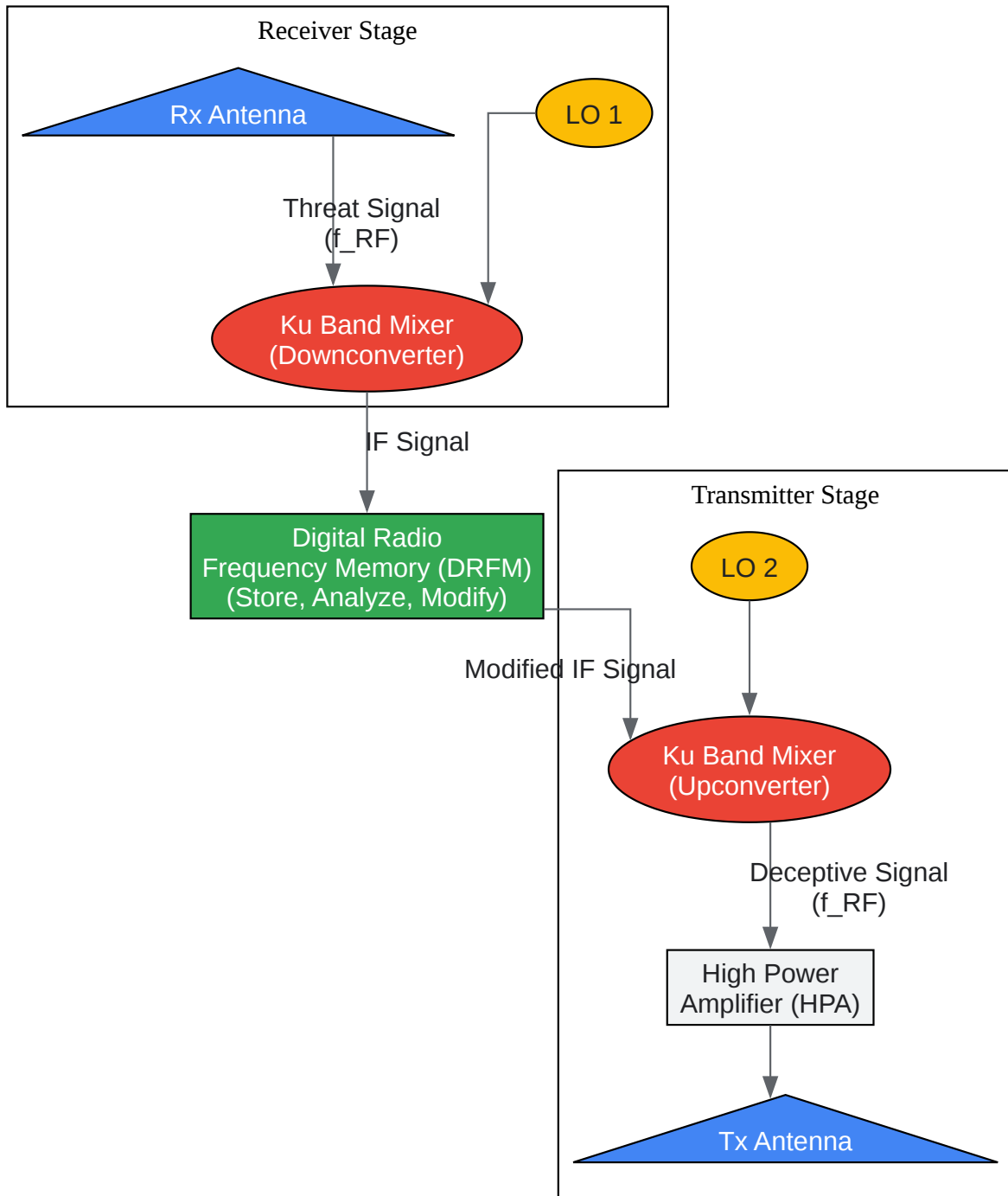

[Click to download full resolution via product page](#)

Caption: Logical workflow of a DRFM-based deception jamming system.

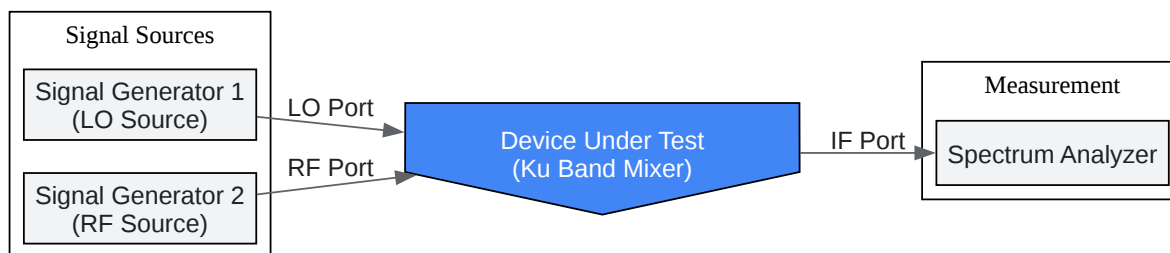

[Click to download full resolution via product page](#)

Caption: Experimental setup for characterizing Ku band mixer performance.

### Need Custom Synthesis?

BenchChem offers custom synthesis for rare earth carbides and specific isotopic labeling.

Email: [info@benchchem.com](mailto:info@benchchem.com) or [Request Quote Online](#).

## References

- 1. [Electronic warfare - Wikipedia \[en.wikipedia.org\]](#)
- 2. [What To Know About Electronic Warfare: WideBand Systems/Akon, Inc \[pentech.com\]](#)
- 3. [Military Electronic Warfare Equipment \(EW\) and Jamming Systems \[army-technology.com\]](#)
- 4. [Ku band - Wikipedia \[en.wikipedia.org\]](#)
- 5. [spire.com \[spire.com\]](#)
- 6. [What are the benefits of KU band - DOLPH MICROWAVE \[dolphmicrowave.com\]](#)
- 7. [ESA - Satellite frequency bands \[esa.int\]](#)
- 8. [intelsat.com \[intelsat.com\]](#)
- 9. [Ku-Band \[macom.com\]](#)
- 10. [everythingrf.com \[everythingrf.com\]](#)
- 11. [info.spectrumcontrol.com \[info.spectrumcontrol.com\]](#)
- 12. [allelcoelec.com \[allelcoelec.com\]](#)

- [13. The Basics of Mixers | DigiKey \[digikey.com\]](#)
- [14. Electronic warfare - Frequency Electronics \[frequelec.com\]](#)
- [15. scribd.com \[scribd.com\]](#)
- [16. hushkit.net \[hushkit.net\]](#)
- To cite this document: BenchChem. [Introduction: The Intersection of the Ku Band and Electronic Warfare]. BenchChem, [2026]. [Online PDF]. Available at: [\[https://www.benchchem.com/product/b12422540/docs#introduction-the-intersection-of-the-ku-band-and-electronic-warfare\]](https://www.benchchem.com/product/b12422540/docs#introduction-the-intersection-of-the-ku-band-and-electronic-warfare)

---

### Disclaimer & Data Validity:

The information provided in this document is for Research Use Only (RUO) and is strictly not intended for diagnostic or therapeutic procedures. While BenchChem strives to provide accurate protocols, we make no warranties, express or implied, regarding the fitness of this product for every specific experimental setup.

**Technical Support:** The protocols provided are for reference purposes. Unsure if this reagent suits your experiment?

**Need Industrial/Bulk Grade?** [Request Custom Synthesis Quote](#)

## BenchChem

Our mission is to be the trusted global source of essential and advanced chemicals, empowering scientists and researchers to drive progress in science and industry.

### Contact

Address: 3281 E Guasti Rd

Ontario, CA 91761, United States

Phone: (601) 213-4426

Email: [info@benchchem.com](mailto:info@benchchem.com)

[Contact our Ph.D. Support Team for a compatibility check](#)

