

CMD178 Technical Support Center: Optimizing Conversion Loss

Author: BenchChem Technical Support Team. **Date:** April 2026

Compound of Interest

Compound Name: CMD178
Cat. No.: B12422540

[Get Quote](#)

This technical support center provides researchers, scientists, and drug development professionals with troubleshooting guides and frequently asked questions (FAQs) to address and improve conversion loss in a **CMD178** mixer setup.

Troubleshooting Guide

High conversion loss can significantly impact the performance of your RF system. This guide provides a step-by-step approach to identifying and mitigating common issues in a **CMD178** setup.

Q1: My measured conversion loss is significantly higher than the typical values in the datasheet. What are the first steps to troubleshoot this?

A1: Start by verifying your basic setup and comparing it against the **CMD178**'s recommended operating conditions.

- **Verify LO Drive Level:** The **CMD178** is specified with a typical Local Oscillator (LO) drive level of +13 dBm.[1] An incorrect LO power level is a common cause of poor conversion loss. [2]

- **Check Frequencies:** Ensure your RF, LO, and IF frequencies are within the specified ranges for the **CMD178**. The RF and LO frequency range is 11 to 21 GHz, and the IF frequency range is DC to 6 GHz.[1]
- **Inspect Connections:** Check all cable connections for integrity and ensure they are properly torqued. Poor connections can introduce significant loss.
- **Power Supply:** If you are using any active components in your setup, verify that the power supplies are providing the correct voltage and current.

Q2: I've confirmed my basic setup parameters are correct, but the conversion loss is still high. What's the next step?

A2: The next step is to investigate impedance matching at all three ports (RF, LO, and IF).

Impedance mismatch is a primary contributor to high conversion loss as it causes reflections and power loss. The **CMD178** is designed for a 50-ohm system.

- **Use a Vector Network Analyzer (VNA):** Measure the return loss (S11) at the RF, LO, and IF ports. A high return loss (low S11 magnitude in dB) indicates a good impedance match.
- **Matching Networks:** If you identify a significant mismatch, you may need to implement a matching network at the affected port. This can be a simple stub tuner or a more complex lumped element network.
- **Component Placement:** In a PCB layout, the proximity of other components and the length of transmission lines can affect impedance. Ensure your layout follows good RF design practices.

Q3: Could the LO signal quality be affecting my conversion loss?

A3: Yes, the purity of the LO signal is important.

- **Harmonics:** Excessive harmonics in the LO signal can lead to unwanted mixing products and increased conversion loss. Use a low-pass filter on the LO path if you suspect high harmonic content.

- **Phase Noise:** While less likely to be the primary cause of high conversion loss, high phase noise in the LO can degrade the overall performance of your system.

Q4: I'm still experiencing high conversion loss after checking the LO and impedance matching. What other factors could be at play?

A4: At this point, consider more subtle effects and potential damage to the device.

- **Signal Leakage:** Poor isolation between the ports can lead to signal leakage, which can affect the mixer's performance. The **CMD178** datasheet specifies the isolation between the ports.^[1] Ensure your layout and shielding are adequate to maintain this isolation.
- **Device Handling:** The **CMD178** is a sensitive semiconductor device. Ensure proper electrostatic discharge (ESD) precautions were taken during handling. ESD damage can degrade performance or cause complete failure.
- **Operating Temperature:** The **CMD178** is specified for an operating temperature range of -40 to 85 °C.^[1] Operating outside this range can affect its performance.

Frequently Asked Questions (FAQs)

Q: What is the typical conversion loss I should expect from the **CMD178**?

A: The typical conversion loss for the **CMD178** is around 6 to 7 dB, depending on the frequency. Refer to the datasheet for the full performance curves.

Q: How does the LO drive level affect conversion loss?

A: The LO signal acts as the switching signal for the mixer's internal diodes. An optimal LO drive level ensures the diodes are fully switched on and off, leading to the most efficient mixing and lowest conversion loss. Too low of a drive level will result in higher conversion loss, while an excessively high level can overdrive the mixer, leading to distortion and potentially damaging the device. For the **CMD178**, the recommended LO drive level is +13 dBm.^[1]

Q: Can I operate the **CMD178** with a lower LO drive level?

A: The **CMD178** can operate with an LO drive level as low as +9 dBm, but this will result in a higher conversion loss.^[3]

Q: Does the IF frequency affect the conversion loss?

A: For the **CMD178**, the conversion loss is relatively flat across its IF frequency range of DC to 6 GHz. However, it's always good practice to check the datasheet for any variations at your specific IF.

Quantitative Data Summary

The following table summarizes the key performance specifications of the **CMD178** relevant to conversion loss, as provided in the datasheet.^[1]

Parameter	Min	Typ	Max	Units	Conditions
RF & LO Frequency Range	11	-	21	GHz	
IF Frequency Range	DC	-	6	GHz	
Conversion Loss (13-17 GHz)	-	6	8	dB	IF = 100 MHz, LO = +13 dBm
Conversion Loss (11-21 GHz)	-	7	10	dB	IF = 100 MHz, LO = +13 dBm
LO Drive Level	+9	+13	+22	dBm	

Experimental Protocols

Methodology for Measuring Conversion Loss

This protocol outlines the steps to accurately measure the conversion loss of the **CMD178**.

Equipment Needed:

- Vector Network Analyzer (VNA) with frequency offset mode
- Two signal generators (for RF and LO signals)
- Spectrum analyzer
- 50-ohm terminations
- Low-loss RF cables
- DC power supply (if any active components are used)
- **CMD178** test fixture

Procedure:

- Calibration: Calibrate the VNA and cables for the frequency ranges of your RF and IF signals.
- Setup:
 - Connect the RF signal generator to the RF port of the **CMD178**.
 - Connect the LO signal generator to the LO port.
 - Connect the IF port to the input of the VNA (or spectrum analyzer).
 - Terminate the unused port of the mixer with a 50-ohm load if not being measured.
- Set Signal Levels:
 - Set the LO signal generator to the desired frequency and a power level of +13 dBm.
 - Set the RF signal generator to the desired frequency and a low power level (e.g., -10 dBm) to ensure the mixer is operating in its linear region.
- Measurement:
 - Measure the power of the RF input signal at the RF port using the VNA or a power meter.

- Measure the power of the downconverted IF output signal at the IF port using the VNA in frequency offset mode or a spectrum analyzer.
- Calculation: The conversion loss in dB is calculated as: Conversion Loss (dB) = P_{RF} (dBm) - P_{IF} (dBm) Where P_{RF} is the power of the RF input signal and P_{IF} is the power of the IF output signal.
- Swept Measurement: For a broader characterization, sweep the RF frequency while keeping the LO frequency fixed and record the conversion loss across the band of interest.

Mandatory Visualizations

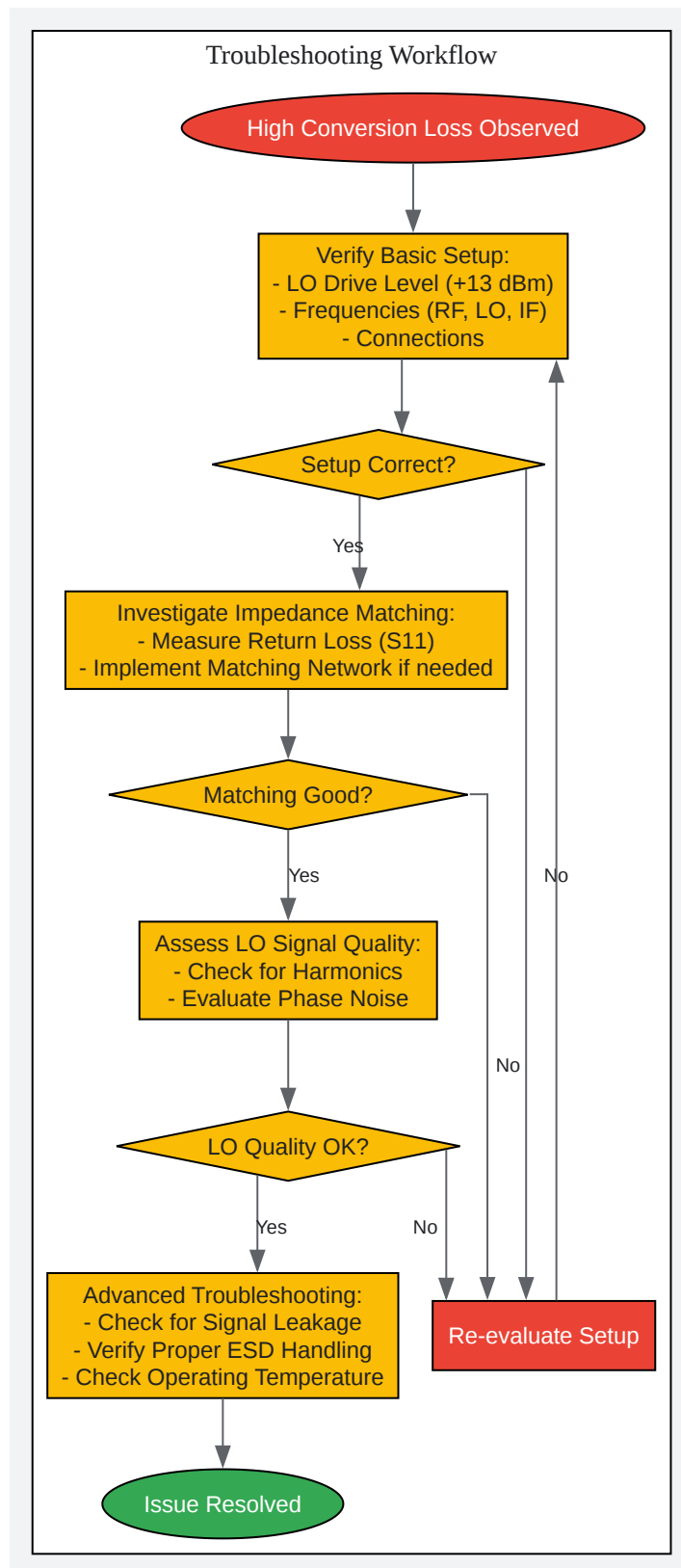

[Click to download full resolution via product page](#)

Caption: Troubleshooting workflow for high conversion loss in a **CMD178** setup.

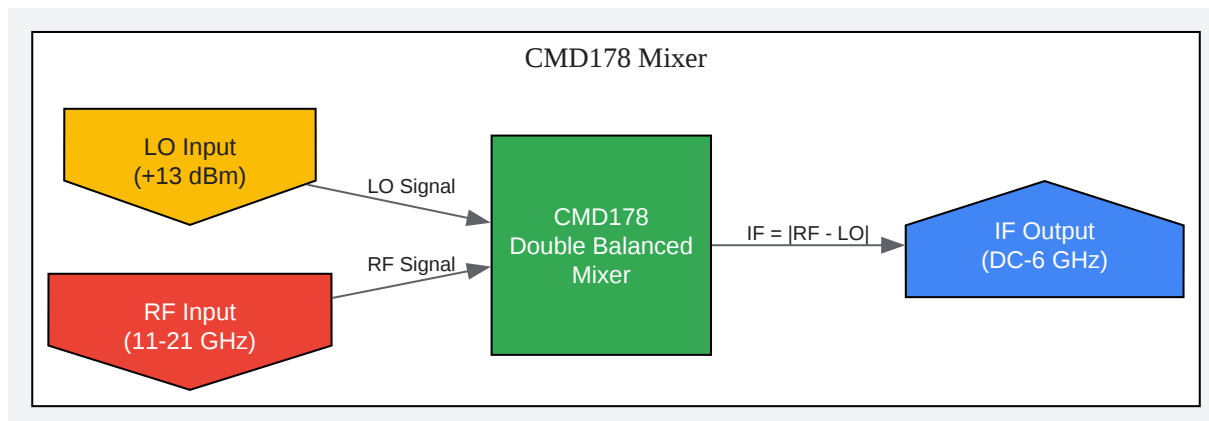

[Click to download full resolution via product page](#)

Caption: Simplified signal path diagram for the **CMD178** mixer in a downconversion setup.

Need Custom Synthesis?

BenchChem offers custom synthesis for rare earth carbides and specific isotopic labeling.

Email: info@benchchem.com or [Request Quote Online](#).

References

- 1. [qorvo.com](https://www.qorvo.com) [qorvo.com]
- 2. [Understanding the Conversion Loss and Gain of a Mixer | Erzia](#) [erzia.com]
- 3. [CMD178 - Qorvo](#) [qorvo.com]
- To cite this document: BenchChem. [CMD178 Technical Support Center: Optimizing Conversion Loss]. BenchChem, [2026]. [Online PDF]. Available at: [\[https://www.benchchem.com/product/b12422540/docs#cmd178-technical-support-center-optimizing-conversion-loss\]](https://www.benchchem.com/product/b12422540/docs#cmd178-technical-support-center-optimizing-conversion-loss)

Disclaimer & Data Validity:

The information provided in this document is for Research Use Only (RUO) and is strictly not intended for diagnostic or therapeutic procedures. While BenchChem strives to provide accurate protocols, we make no warranties, express or implied, regarding the fitness of this product for every specific experimental setup.

Technical Support: The protocols provided are for reference purposes. Unsure if this reagent suits your experiment?

Need Industrial/Bulk Grade? [Request Custom Synthesis Quote](#)

BenchChem

Our mission is to be the trusted global source of essential and advanced chemicals, empowering scientists and researchers to drive progress in science and industry.

Contact

Address: 3281 E Guasti Rd
Ontario, CA 91761, United States
Phone: (601) 213-4426
Email: info@benchchem.com

[Contact our Ph.D. Support Team for a compatibility check](#)