

Application Note: Integrating the CMD178 for Downconverter Applications

Author: BenchChem Technical Support Team. **Date:** April 2026

Compound of Interest

Compound Name: CMD178
Cat. No.: B12422540

[Get Quote](#)

For Researchers, Scientists, and Drug Development Professionals

Abstract

This document provides a detailed guide for integrating the Qorvo **CMD178**, a passive double-balanced mixer, into a downconverter circuit. The **CMD178** is well-suited for applications requiring frequency conversion from the Ku-band (11-21 GHz) to a lower intermediate frequency (IF). This application note will cover the fundamental principles of downconversion, a typical circuit topology, component selection considerations, and detailed experimental protocols for performance characterization. The intended audience is researchers and scientists who may be utilizing microwave systems in their experimental setups, such as in certain spectroscopic or imaging applications, and require a practical understanding of the underlying hardware.

Introduction to Downconversion and the CMD178 Mixer

In many radio frequency (RF) systems, it is necessary to convert a high-frequency signal to a lower frequency for easier processing. This process is known as downconversion.[1][2] A key

component in this process is the mixer, which combines the incoming RF signal with a local oscillator (LO) signal to produce sum and difference frequencies. In a downconverter, the difference frequency, or IF, is the desired output.

The **CMD178** is a passive double-balanced mixer that offers low conversion loss, high isolation between its ports, and a wide IF bandwidth, making it an excellent choice for downconverter applications in the 11-21 GHz range.[3][4][5] Its passive design means it does not require a DC power supply, simplifying circuit design.

Downconverter Circuit Architecture

A typical downconverter circuit consists of several key components in addition to the mixer. A generic block diagram is presented below, which can be adapted based on specific application requirements.

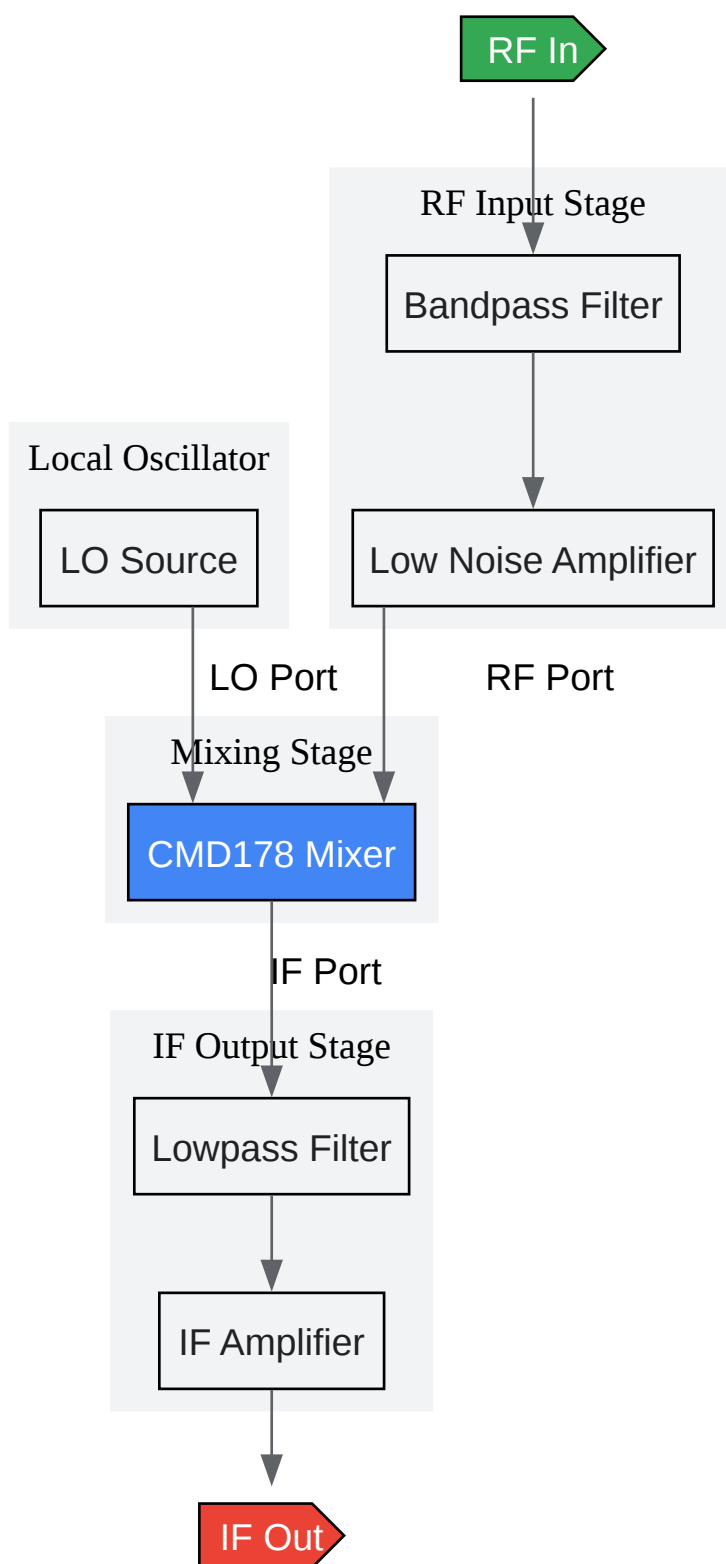

[Click to download full resolution via product page](#)

Downconverter Block Diagram

Component Description:

- RF Input Stage:
 - Bandpass Filter (BPF): Selects the desired RF input frequency band and rejects out-of-band signals.
 - Low Noise Amplifier (LNA): Amplifies the weak incoming RF signal while adding minimal noise to maintain a good signal-to-noise ratio.
- Mixing Stage:
 - **CMD178** Mixer: Combines the amplified RF signal with the LO signal to generate the IF signal.
- Local Oscillator (LO):
 - LO Source: A stable frequency source that provides the mixing signal. The frequency of the LO determines the frequency of the resulting IF signal ($f_{IF} = |f_{RF} - f_{LO}|$).
- IF Output Stage:
 - Lowpass Filter (LPF): Removes the unwanted sum frequency ($f_{RF} + f_{LO}$) and other high-frequency products from the mixer output.
 - IF Amplifier: Amplifies the IF signal to a suitable level for subsequent processing.

CMD178 Integration and Performance Data

The **CMD178** is a die-level product, while the **CMD178C3** is the surface-mount packaged version. For ease of integration in most laboratory settings, the **CMD178C3** is recommended. The following tables summarize the key performance parameters of the **CMD178** family, which are crucial for downconverter design.

Table 1: **CMD178/CMD178C3** Electrical Specifications

Parameter	Typical Value	Units
RF & LO Frequency Range	11 - 21	GHz
IF Frequency Range	DC - 6	GHz
Conversion Loss	6	dB
LO to RF Isolation	45	dB
LO to IF Isolation	45	dB
RF to IF Isolation	26	dB
Input P1dB	9	dBm
Input IP3	16	dBm
LO Drive Level	+9 to +15	dBm

Data sourced from the **CMD178** and **CMD178C3** datasheets.

Experimental Protocols for Downconverter Characterization

The following protocols describe the methodology for measuring the key performance metrics of a downconverter circuit featuring the **CMD178**.

Experimental Setup

The following diagram illustrates a typical setup for characterizing the downconverter module.

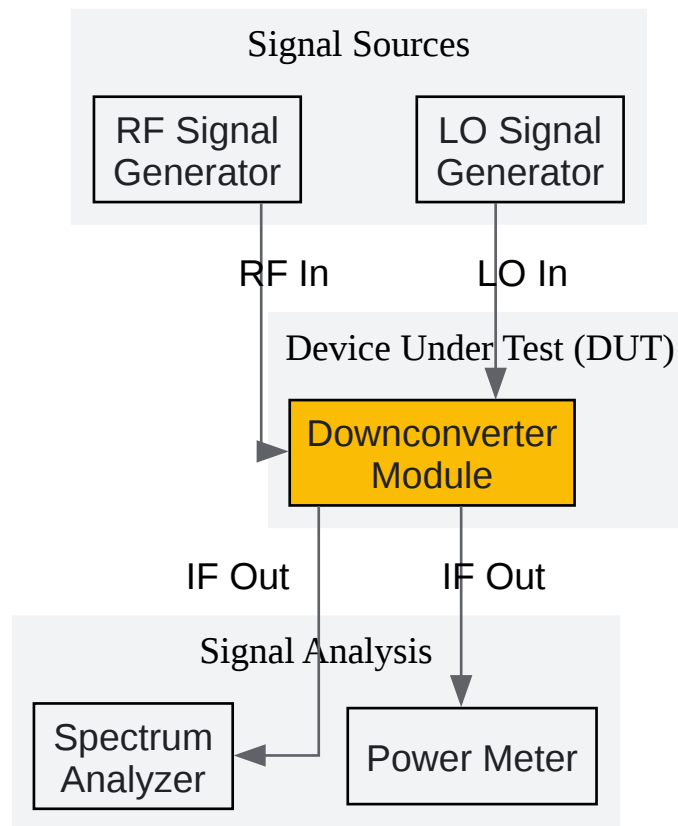

[Click to download full resolution via product page](#)

Downconverter Test Setup

Conversion Gain/Loss Measurement

- Setup: Connect the equipment as shown in the measurement setup diagram.
- RF Signal: Set the RF signal generator to the desired input frequency (e.g., 15 GHz) and a power level well below the P1dB compression point of the mixer (e.g., -20 dBm).
- LO Signal: Set the LO signal generator to the desired LO frequency (e.g., 14 GHz for a 1 GHz IF) and a power level within the recommended range for the **CMD178** (e.g., +13 dBm).
- Measurement:
 - Measure the input power at the RF port of the downconverter using the power meter.

- Measure the output power at the IF port of the downconverter at the IF frequency (1 GHz in this example) using the spectrum analyzer or power meter.
- Calculation: Conversion Gain (dB) = P_out (dBm) - P_in (dBm). For a passive mixer like the **CMD178**, this will be a negative value, referred to as conversion loss.

Port-to-Port Isolation Measurement

- LO to RF Isolation:
 - Terminate the RF and IF ports with 50-ohm loads.
 - Apply the LO signal at its nominal power level.
 - Measure the power of the LO signal that leaks to the RF port using the spectrum analyzer.
 - Isolation (dB) = P_LO (dBm) - P_leakage_RF (dBm).
- LO to IF Isolation:
 - Terminate the RF and IF ports with 50-ohm loads.
 - Apply the LO signal at its nominal power level.
 - Measure the power of the LO signal that leaks to the IF port.
 - Isolation (dB) = P_LO (dBm) - P_leakage_IF (dBm).
- RF to IF Isolation:
 - Terminate the LO and IF ports with 50-ohm loads.
 - Apply the RF signal at its nominal power level.
 - Measure the power of the RF signal that leaks to the IF port.
 - Isolation (dB) = P_RF (dBm) - P_leakage_IF (dBm).

1 dB Compression Point (P1dB) Measurement

- Setup: Use the same setup as for conversion gain measurement.
- Procedure:
 - Set the RF and LO signals to their nominal frequencies and power levels.
 - Gradually increase the input power from the RF signal generator in small steps (e.g., 1 dB).
 - For each input power level, measure the output power at the IF frequency.
 - Plot the output power versus the input power.
- Determination: The input P1dB is the input power level at which the measured conversion gain has decreased by 1 dB from its small-signal value.

Third-Order Intercept Point (IP3) Measurement

- Setup: Use a two-tone RF signal source or two separate RF signal generators combined with a power combiner. The two tones should be closely spaced in frequency (e.g., $f_1 = 15.00$ GHz and $f_2 = 15.01$ GHz).
- Procedure:
 - Apply the two-tone RF signal to the downconverter input.
 - On the spectrum analyzer at the IF output, observe the two main IF tones and the third-order intermodulation (IMD3) products at $2f_1 - f_2$ and $2f_2 - f_1$.
 - Measure the power of one of the main IF tones and one of the IMD3 products.
- Calculation: $\text{Input IP3 (dBm)} = P_{\text{in}} \text{ (dBm)} + (P_{\text{out}} \text{ (dBm)} - P_{\text{IMD3}} \text{ (dBm)}) / 2$.

Conclusion

The **CMD178** is a versatile and high-performance mixer suitable for a wide range of downconverter applications. By carefully selecting supporting components such as filters and amplifiers and following the detailed characterization protocols outlined in this note,

researchers and scientists can successfully integrate this device into their systems and validate its performance. The provided data and methodologies serve as a comprehensive starting point for the design and implementation of robust and reliable downconverter circuits.

Need Custom Synthesis?

BenchChem offers custom synthesis for rare earth carbides and specific isotopic labeling.

Email: info@benchchem.com or [Request Quote Online](#).

References

- [1. researchgate.net \[researchgate.net\]](#)
- [2. Access to this page has been denied. \[mouser.com\]](#)
- [3. Design of a Fixed IF Down-Conversion Double-Balanced Mixer for UHF Band Applications \[mdpi.com\]](#)
- [4. CMD178 - Qorvo \[qorvo.com\]](#)
- [5. qorvo.com \[qorvo.com\]](#)
- To cite this document: BenchChem. [Application Note: Integrating the CMD178 for Downconverter Applications]. BenchChem, [2026]. [Online PDF]. Available at: [\[https://www.benchchem.com/product/b12422540/docs#application-note-integrating-the-cmd178-for-downconverter-applications\]](https://www.benchchem.com/product/b12422540/docs#application-note-integrating-the-cmd178-for-downconverter-applications)

Disclaimer & Data Validity:

The information provided in this document is for Research Use Only (RUO) and is strictly not intended for diagnostic or therapeutic procedures. While BenchChem strives to provide accurate protocols, we make no warranties, express or implied, regarding the fitness of this product for every specific experimental setup.

Technical Support: The protocols provided are for reference purposes. Unsure if this reagent suits your experiment?

Need Industrial/Bulk Grade? [Request Custom Synthesis Quote](#)

BenchChem

Our mission is to be the trusted global source of essential and advanced chemicals, empowering scientists and researchers to drive progress in science and industry.

Contact

Address: 3281 E Guasti Rd

Ontario, CA 91761, United States

Phone: (601) 213-4426

Email: info@benchchem.com

[Contact our Ph.D. Support Team for a compatibility check](#)