

A Comparative Guide to RF to IF Isolation in the CMD178 Mixer

Author: BenchChem Technical Support Team. **Date:** April 2026

Compound of Interest

Compound Name: CMD178
Cat. No.: B12422540

[Get Quote](#)

For researchers, scientists, and professionals in drug development utilizing sensitive RF equipment, understanding the performance of individual components is critical. This guide provides a comparative analysis of the RF to IF isolation of the Qorvo **CMD178** double-balanced mixer against other market alternatives. The data presented is supported by detailed experimental protocols for accurate measurement.

Performance Comparison

The RF to IF isolation is a crucial parameter in mixer performance, indicating the degree of attenuation of the RF signal that leaks to the Intermediate Frequency (IF) port.[1][2] Higher isolation values are desirable as they minimize interference from the RF source at the IF output.[2]

The Qorvo **CMD178** is a general-purpose double-balanced mixer with an RF and Local Oscillator (LO) frequency range of 11 to 21 GHz and an IF range from DC to 6 GHz. Below is a comparison of its RF to IF isolation with other commercially available mixers with comparable frequency ranges.

Part Number	Manufacturer	RF/LO Frequency Range (GHz)	Typical RF to IF Isolation (dB)
CMD178	Qorvo	11 - 21	26
M1-0220LP	Marki Microwave	2 - 20	25[3][4]
M1-0620NE-2	Marki Microwave	6 - 20	25[5]
M1-0620SP	Marki Microwave	6 - 20	25[6]
M1-0220NP	Marki Microwave	2 - 20	25[7]

Note: The Marki Microwave M1-0220LP is a discontinued product but is included for comparative purposes.

Experimental Protocols

Accurate measurement of RF to IF isolation is essential for verifying component performance. The following are detailed methodologies for measuring the RF to IF isolation of a mixer using either a Vector Network Analyzer (VNA) or a Spectrum Analyzer. It is critical that the Local Oscillator (LO) is powered on and set to its normal operating level during the measurement, as the isolation is dependent on the LO drive level.[8][9]

Method 1: Measurement using a Vector Network Analyzer (VNA)

A VNA is the preferred instrument for characterizing mixer performance as it can provide accurate, swept-frequency measurements.

Equipment Required:

- Vector Network Analyzer (VNA) with at least two ports
- Signal Generator (for the LO signal)
- DC Power Supply (if the mixer requires it)
- 50 Ω terminations

- High-quality coaxial cables

Procedure:

- Calibration: Perform a full two-port calibration of the VNA over the RF frequency range of the mixer. This typically involves SHORT, OPEN, LOAD, and THRU standards.
- Setup:
 - Connect Port 1 of the VNA to the RF port of the mixer under test (MUT).
 - Connect Port 2 of the VNA to the IF port of the MUT.
 - Connect the signal generator to the LO port of the MUT.
 - Ensure all unused ports are terminated with a 50 Ω load.
- Instrument Configuration:
 - Set the VNA to measure the S21 parameter (forward transmission).
 - Set the sweep frequency of the VNA to cover the desired RF frequency range.
 - Set the power level of VNA Port 1 to a level appropriate for the mixer's RF input.
 - Set the signal generator to the desired LO frequency and power level as specified in the mixer's datasheet.
- Measurement:
 - Turn on the LO signal generator.
 - The VNA will display the S21 measurement, which represents the RF to IF isolation in dB.

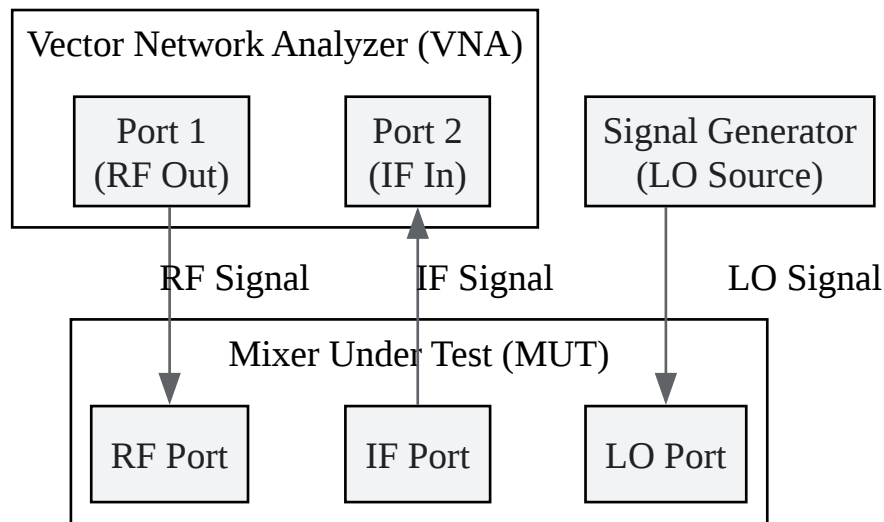

[Click to download full resolution via product page](#)

RF to IF Isolation Measurement with a VNA

Method 2: Measurement using a Spectrum Analyzer

A spectrum analyzer with a tracking generator can also be used to measure RF to IF isolation.

Equipment Required:

- Spectrum Analyzer with a Tracking Generator
- Signal Generator (for the LO signal)
- DC Power Supply (if the mixer requires it)
- 50 Ω terminations
- High-quality coaxial cables

Procedure:

- Normalization:

- Connect the tracking generator output directly to the spectrum analyzer input using a coaxial cable.
- Enable the tracking generator and normalize the display to establish a 0 dB reference level across the frequency range of interest.
- Setup:
 - Connect the tracking generator output to the RF port of the MUT.
 - Connect the IF port of the MUT to the spectrum analyzer input.
 - Connect the signal generator to the LO port of the MUT.
 - Terminate the LO port with a 50 Ω load if it is not being used.
- Instrument Configuration:
 - Set the spectrum analyzer to the same frequency sweep as the tracking generator.
 - Set the signal generator to the desired LO frequency and power level.
- Measurement:
 - Turn on the LO signal generator.
 - The spectrum analyzer will display the power level of the RF signal that has leaked through to the IF port. The difference between the normalized reference level and the measured power level is the RF to IF isolation in dB.

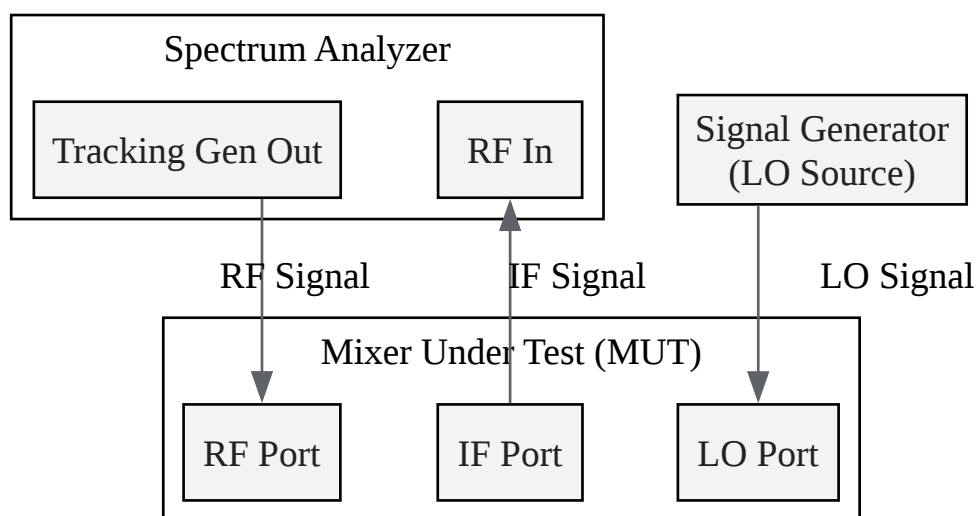

[Click to download full resolution via product page](#)

RF to IF Isolation Measurement with a Spectrum Analyzer

Need Custom Synthesis?

BenchChem offers custom synthesis for rare earth carbides and specific isotopic labeling.

Email: info@benchchem.com or [Request Quote Online](#).

References

- 1. rfwireless-world.com [rfwireless-world.com]
- 2. everythingrf.com [everythingrf.com]
- 3. M1-0220LP Marki Microwave RF Mixer|RFMW [rfmw.com]
- 4. shop.markimicrowave.com [shop.markimicrowave.com]
- 5. shop.markimicrowave.com [shop.markimicrowave.com]
- 6. shop.markimicrowave.com [shop.markimicrowave.com]
- 7. M1-0220NP Marki Microwave RF Mixer|RFMW [rfmw.com]
- 8. measurement - Mixer RF-to-IF isolation - Electrical Engineering Stack Exchange [electronics.stackexchange.com]
- 9. Isolation [helpfiles.keysight.com]

- To cite this document: BenchChem. [A Comparative Guide to RF to IF Isolation in the CMD178 Mixer]. BenchChem, [2026]. [Online PDF]. Available at: [<https://www.benchchem.com/product/b12422540/docs#a-comparative-guide-to-rf-to-if-isolation-in-the-cmd178-mixer>]

Disclaimer & Data Validity:

The information provided in this document is for Research Use Only (RUO) and is strictly not intended for diagnostic or therapeutic procedures. While BenchChem strives to provide accurate protocols, we make no warranties, express or implied, regarding the fitness of this product for every specific experimental setup.

Technical Support: The protocols provided are for reference purposes. Unsure if this reagent suits your experiment?

Need Industrial/Bulk Grade? [Request Custom Synthesis Quote](#)

BenchChem

Our mission is to be the trusted global source of essential and advanced chemicals, empowering scientists and researchers to drive progress in science and industry.

Contact

Address: 3281 E Guasti Rd
Ontario, CA 91761, United States
Phone: (601) 213-4426
Email: info@benchchem.com

[Contact our Ph.D. Support Team for a compatibility check](#)