

# A Comparative Analysis for Researchers and Drug Development Professionals

**Author:** BenchChem Technical Support Team. **Date:** April 2026

## Compound of Interest

Compound Name: *Benzyl benzoylcarbamate*

CAS No.: 38091-74-6

Cat. No.: B14663713

[Get Quote](#)

In the landscape of pharmaceutical and materials science, the precise structural elucidation of novel compounds is paramount. Mass spectrometry stands as a cornerstone analytical technique, providing invaluable insights into molecular weight and structure through the analysis of fragmentation patterns. This guide offers a comprehensive examination of the predicted mass spectrometry fragmentation of **benzyl benzoylcarbamate**, a molecule of interest due to its constituent functional groups that are prevalent in various bioactive compounds and polymers.

As Senior Application Scientists, our goal is to not only present data but to also provide the underlying scientific rationale for the observed or predicted fragmentation pathways. This guide is structured to deliver a deep, mechanistically-grounded understanding of how **benzyl benzoylcarbamate** is expected to behave under mass spectrometric analysis, comparing its fragmentation to that of structurally related compounds. The information herein is designed to empower researchers in their analytical endeavors, from method development to the confident identification of this and similar molecules.

# Predicted Fragmentation Pathways of Benzyl

## Benzoylcarbamate

The fragmentation of **benzyl benzoylcarbamate** is anticipated to be a composite of the characteristic fragmentation patterns of its three key functionalities: the benzyl group, the benzoyl group, and the carbamate linkage. The ionization method employed will significantly influence the observed fragmentation. Under Electron Ionization (EI), a hard ionization technique, extensive fragmentation is expected. In contrast, softer ionization methods like Electrospray Ionization (ESI) or Atmospheric Pressure Photoionization (APPI) will likely yield a more prominent molecular ion or protonated molecule, with fragmentation induced via collision-induced dissociation (CID).<sup>[1][2]</sup>

## Key Fragmentation Reactions

Several key fragmentation reactions are predicted for **benzyl benzoylcarbamate**:

- **Formation of the Benzoyl Cation:** A primary and often dominant fragmentation pathway for compounds containing a benzoyl moiety is the formation of the highly stable benzoyl cation ( $C_6H_5CO^+$ ) at a mass-to-charge ratio ( $m/z$ ) of 105.<sup>[3][4]</sup> This is frequently the base peak in the mass spectra of benzoyl derivatives. Subsequent loss of a neutral carbon monoxide (CO) molecule can lead to the formation of the phenyl cation ( $C_6H_5^+$ ) at  $m/z$  77.<sup>[3]</sup>
- **Formation of the Tropylium Ion:** The presence of a benzyl group strongly suggests the formation of a fragment at  $m/z$  91. This is attributed to the benzyl cation ( $C_6H_5CH_2^+$ ), which readily rearranges to the very stable, aromatic tropylium ion ( $C_7H_7^+$ ).<sup>[5][6][7]</sup>
- **Cleavage of the Carbamate Linkage:** The carbamate bond is susceptible to cleavage. This can occur on either side of the carbonyl group, leading to various fragment ions.
- **Rearrangement Reactions:** As seen in related N-benzoyl compounds, hydrogen rearrangements can occur, potentially leading to unique fragment ions.<sup>[8]</sup>

The following diagram illustrates the predicted primary fragmentation pathways of **benzyl benzoylcarbamate** under mass spectrometric analysis.

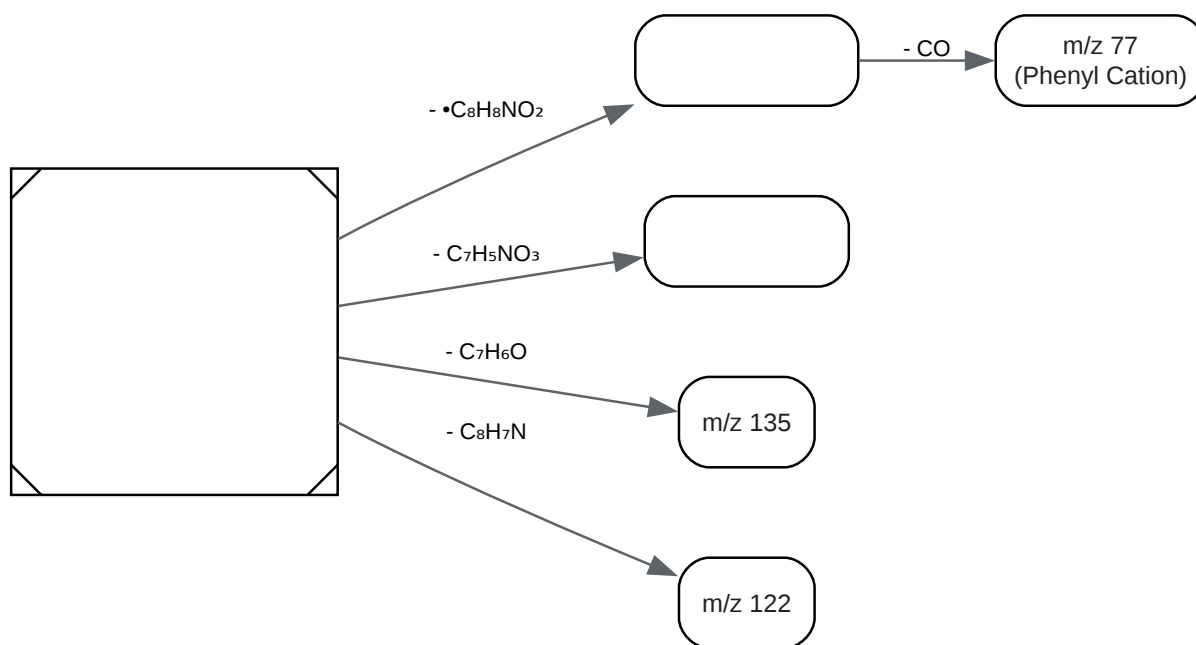

[Click to download full resolution via product page](#)

Caption: Predicted major fragmentation pathways of **benzyl benzoylcarbamate**.

## Comparative Fragmentation Analysis

To better understand the fragmentation of **benzyl benzoylcarbamate**, it is instructive to compare its predicted fragmentation pattern with those of its simpler analogues: benzyl carbamate and methyl benzoate.

Compound	Key Fragment Ions (m/z)	Interpretation
Benzyl Benzoylcarbamate	105, 77, 91, 135, 122	Combination of benzoyl, benzyl, and carbamate fragmentation.
Benzyl Carbamate	91, 108, 79, 44	Dominated by benzyl group fragmentation (m/z 91). Loss of CO <sub>2</sub> from the molecular ion is also possible.
Methyl Benzoate	105, 77, 136 (M <sup>+</sup> )	Classic benzoyl fragmentation with a prominent benzoyl cation (m/z 105).

This comparison highlights how the different structural motifs contribute to the overall mass spectrum. The presence of both benzoyl and benzyl groups in **benzyl benzoylcarbamate** is expected to lead to a richer, more complex fragmentation pattern than its simpler counterparts.

## Experimental Protocol for Mass Spectrometric Analysis

This section provides a detailed, step-by-step methodology for the analysis of **benzyl benzoylcarbamate** using both Gas Chromatography-Mass Spectrometry (GC-MS) and Liquid Chromatography-Tandem Mass Spectrometry (LC-MS/MS).

### GC-MS Analysis

GC-MS is a suitable technique for the analysis of thermally stable and volatile compounds.

- Sample Preparation:
  - Prepare a stock solution of **benzyl benzoylcarbamate** in a suitable solvent (e.g., dichloromethane or ethyl acetate) at a concentration of 1 mg/mL.
  - Perform serial dilutions to obtain working solutions in the range of 1-100 µg/mL.
- GC-MS Instrumentation and Parameters:

- Gas Chromatograph: Agilent 8890 GC or equivalent.
- Injector: Split/splitless injector, operated in splitless mode at 250°C.
- Column: HP-5ms (30 m x 0.25 mm, 0.25 µm film thickness) or equivalent.
- Oven Program: Initial temperature of 100°C, hold for 1 minute, ramp to 280°C at 15°C/min, and hold for 5 minutes.
- Carrier Gas: Helium at a constant flow rate of 1.2 mL/min.
- Mass Spectrometer: Agilent 5977B MSD or equivalent.
- Ionization Mode: Electron Ionization (EI) at 70 eV.
- Mass Analyzer: Quadrupole, scanning a mass range of m/z 40-500.[3]

## LC-MS/MS Analysis

LC-MS/MS is the preferred method for less volatile or thermally labile compounds and for analysis in complex matrices.[3]

- Sample Preparation:
  - Prepare a stock solution of **benzyl benzoylcarbamate** in methanol or acetonitrile at a concentration of 1 mg/mL.
  - Perform serial dilutions with the mobile phase to obtain working solutions in the range of 0.1-10 µg/mL.
- LC-MS/MS Instrumentation and Parameters:
  - Liquid Chromatograph: Waters ACQUITY UPLC I-Class or equivalent.
  - Column: ACQUITY UPLC BEH C18 (2.1 x 50 mm, 1.7 µm) or equivalent.
  - Mobile Phase A: 0.1% formic acid in water.
  - Mobile Phase B: 0.1% formic acid in acetonitrile.

- Gradient: Start with 5% B, ramp to 95% B over 5 minutes, hold for 2 minutes, and return to initial conditions.
- Flow Rate: 0.4 mL/min.
- Column Temperature: 40°C.
- Mass Spectrometer: Sciex Triple Quad 6500+ or equivalent.
- Ionization Mode: Positive Electrospray Ionization (ESI+).
- Key Parameters: Optimize cone voltage and collision energy to achieve desired fragmentation.[3]
- MS/MS Analysis: Perform product ion scans of the protonated molecule  $[M+H]^+$ . For targeted quantification, Multiple Reaction Monitoring (MRM) can be utilized.[3]

The following diagram illustrates the general workflow for LC-MS/MS analysis.

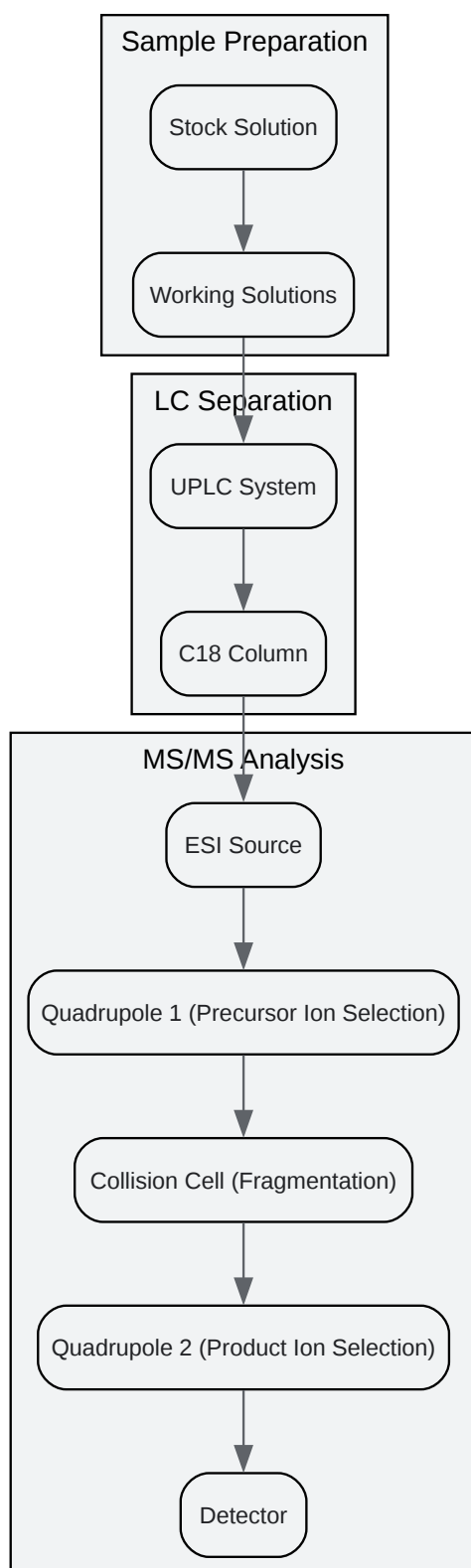

[Click to download full resolution via product page](#)

Caption: General workflow for LC-MS/MS analysis.

## Conclusion

The mass spectrometry fragmentation of **benzyl benzoylcarbamate** is predicted to be a rich interplay of the fragmentation patterns characteristic of its constituent benzoyl, benzyl, and carbamate moieties. The formation of the benzoyl cation ( $m/z$  105) and the tropylium ion ( $m/z$  91) are expected to be prominent features of its mass spectrum. Understanding these fragmentation pathways is crucial for the accurate identification and structural confirmation of this and related compounds in various research and development settings. The provided experimental protocols for both GC-MS and LC-MS/MS serve as a robust starting point for developing analytical methods for the characterization of **benzyl benzoylcarbamate**.

## References

- A Comparative Guide to the Mass Spectrometry Fragmentation Patterns of Benzoyl Deriv
- Gas-Phase Fragmentation Characteristics of Benzyl-Aminated Lysyl-Containing Tryptic Peptides - CORE.
- Mass Spectrometry of N-Benzoyl-2-hydroxyalkylamines.
- Fragmentation of deprotonated N-benzoylpeptides: formation of deproton
- mass spectrometry: tropylium ion - YouTube.
- Gas-Phase Fragmentation Characteristics of Benzyl-Aminated Lysyl-Containing Tryptic Peptides - PMC.
- Mass Spectrometry Fragment
- Gas-phase fragmentation characteristics of benzyl-aminated lysyl-containing tryptic peptides | Journal of the American Society for Mass Spectrometry - ACS Public
- Benzyl carbam
- Fragmentation reactions using electrospray ionization mass spectrometry: an important tool for the structural elucidation and characterization of synthetic and n
- Application Notes and Protocols: Mass Spectrometry Fragmentation of (+)-Benzoylchelidonine - Benchchem.
- Benzylcarbam
- Benzylcarbam
- Mass spectrometry after collision-induced dissociation fragmentation of...
- Determination of Ethyl Carbamate in Commercial Sweetened Sugar Cane Spirit by ESI-MS/MS Using Modified QuEChERS and 18-Crown-6/Trifluoroacetic Acid Spiking Additives - SciELO.
- Benzyl glycidyl carbamate - Optional[MS (GC)] - Spectrum - SpectraBase.
- Carbamyl Benzyl Ester | 621-84-1 - SynThink.

- Chemical Ionization Mass Spectrometry of N-Methylcarbamate Insecticides, Some of Their Metabolites, and Related Compounds | Journal of AOAC INTERN
- Mass Spectrometry - Fragmentation P
- Determination of carbamate pesticide residues in vegetables and fruits by liquid chromatography-atmospheric pressure photoionization-mass spectrometry and atmospheric pressure chemical ioniz
- Investigation of Electron Ionization in Mass Spectrometry: Principles and Applic
- Determination of Carbamate Pesticide Residues in Vegetables and Fruits by Liquid Chromatography–Atmospheric Pressure Photoionization–Mass Spectrometry and Atmospheric Pressure Chemical Ionization–Mass Spectrometry | Journal of Agricultural and Food Chemistry - ACS Public
- Mass Spectrometry: Fragment
- Fragmentation mechanisms in mass spectrometry - Universidad de Guanaju

### Need Custom Synthesis?

BenchChem offers custom synthesis for rare earth carbides and specific isotopic labeling.

Email: [info@benchchem.com](mailto:info@benchchem.com) or [Request Quote Online](#).

## Sources

- [1. Fragmentation reactions using electrospray ionization mass spectrometry: an important tool for the structural elucidation and characterization of synt ... - Natural Product Reports \(RSC Publishing\) DOI:10.1039/C5NP00073D \[pubs.rsc.org\]](#)
- [2. rroj.com \[rroj.com\]](#)
- [3. pdf.benchchem.com \[pdf.benchchem.com\]](#)
- [4. pdf.benchchem.com \[pdf.benchchem.com\]](#)
- [5. youtube.com \[youtube.com\]](#)
- [6. Gas-Phase Fragmentation Characteristics of Benzyl-Aminated Lysyl-Containing Tryptic Peptides - PMC \[pmc.ncbi.nlm.nih.gov\]](#)
- [7. chemconnections.org \[chemconnections.org\]](#)
- [8. cdnsciencepub.com \[cdnsciencepub.com\]](#)
- To cite this document: BenchChem. [A Comparative Analysis for Researchers and Drug Development Professionals]. BenchChem, [2026]. [Online PDF]. Available at:

[\[https://www.benchchem.com/product/b14663713/docs#a-comparative-analysis-for-researchers-and-drug-development-professionals\]](https://www.benchchem.com/product/b14663713/docs#a-comparative-analysis-for-researchers-and-drug-development-professionals)

### Disclaimer & Data Validity:

The information provided in this document is for Research Use Only (RUO) and is strictly not intended for diagnostic or therapeutic procedures. While BenchChem strives to provide accurate protocols, we make no warranties, express or implied, regarding the fitness of this product for every specific experimental setup.

**Technical Support:** The protocols provided are for reference purposes. Unsure if this reagent suits your experiment?

**Need Industrial/Bulk Grade?** [Request Custom Synthesis Quote](#)

## BenchChem

Our mission is to be the trusted global source of essential and advanced chemicals, empowering scientists and researchers to drive progress in science and industry.

### Contact

Address: 3281 E Guasti Rd  
Ontario, CA 91761, United States  
Phone: (601) 213-4426  
Email: [info@benchchem.com](mailto:info@benchchem.com)

[Contact our Ph.D. Support Team for a compatibility check](#)