

Technical Support Center: Lixumistat Hydrochloride Resistance Mechanisms

Author: BenchChem Technical Support Team. **Date:** May 2026

Compound of Interest

Compound Name: *Lixumistat hydrochloride*

Cat. No.: *B12421133*

[Get Quote](#)

This technical support center provides troubleshooting guides and frequently asked questions (FAQs) for researchers, scientists, and drug development professionals investigating resistance mechanisms to **Lixumistat hydrochloride** in cancer cells.

Frequently Asked Questions (FAQs)

Q1: We are observing a gradual decrease in the efficacy of **Lixumistat hydrochloride** in our long-term cancer cell culture experiments. What are the potential resistance mechanisms?

A1: Resistance to **Lixumistat hydrochloride**, a compound targeting both CXCR4 and oxidative phosphorylation (OXPHOS), can be multifaceted. Potential mechanisms include:

- Alterations in the CXCR4/CXCL12 Axis:
 - Upregulation of CXCR4 expression: Increased receptor density on the cell surface can render the existing drug concentration insufficient.
 - Mutations in the CXCR4 gene: Changes in the drug-binding site can reduce the affinity of **Lixumistat hydrochloride**.

- Increased CXCL12 secretion: The tumor microenvironment, including cancer-associated fibroblasts (CAFs), may secrete higher levels of the CXCR4 ligand CXCL12, leading to competitive antagonism.[1][2]
- Activation of Bypass Signaling Pathways: Cancer cells can develop resistance by activating alternative pro-survival and proliferative pathways to compensate for CXCR4 inhibition. These may include:
 - PI3K/AKT/mTOR pathway activation.[1][3]
 - MAPK/ERK pathway activation.[1][2][3]
 - JAK/STAT pathway activation.[1][3]
- Metabolic Reprogramming: As **Lixumistat hydrochloride** also inhibits mitochondrial protein complex 1 (PC1) of the OXPHOS pathway, resistant cells might adapt their metabolism by:
 - Shifting towards glycolysis for ATP production, even in the presence of oxygen (the Warburg effect).
 - Utilizing alternative energy sources.
- Drug Efflux and Metabolism:
 - Increased expression of ATP-binding cassette (ABC) transporters can actively pump the drug out of the cell.[6]
 - Altered cellular metabolism of the drug could lead to its inactivation.[7]
- Induction of Cancer Stem Cell (CSC) Phenotype: The CXCR4/CXCL12 axis is implicated in maintaining cancer stemness.[1] Resistance may be associated with an enrichment of the CSC population, which is often more resistant to therapy.

Q2: Our cancer cell line, previously sensitive to **Lixumistat hydrochloride**, now shows a higher IC50 value. How can we confirm the mechanism of resistance?

A2: To elucidate the specific resistance mechanism, a series of validation experiments are recommended. Here is a suggested workflow:

- Confirm Resistance: Perform dose-response curves with a sensitive parental cell line and your resistant cell line to quantify the shift in IC50.
- Analyze the CXCR4 Axis:
 - qPCR and Western Blot: Compare CXCR4 mRNA and protein expression levels between sensitive and resistant cells.
 - Flow Cytometry: Quantify cell surface CXCR4 expression.
 - Sanger or Next-Generation Sequencing: Sequence the CXCR4 gene to identify potential mutations.
 - ELISA: Measure the concentration of CXCL12 in the conditioned media of your cell cultures.
- Investigate Bypass Pathways:
 - Western Blot/Phospho-arrays: Probe for the phosphorylated (active) forms of key proteins in the PI3K/AKT, MAPK/ERK, and JAK/STAT pathways (e.g., p-AKT, p-ERK, p-STAT3).
- Assess Metabolic Changes:
 - Seahorse Assay: Measure the oxygen consumption rate (OCR) and extracellular acidification rate (ECAR) to assess changes in OXPHOS and glycolysis.
 - Metabolomics: Perform a comprehensive analysis of cellular metabolites.
- Evaluate Drug Efflux:
 - qPCR/Western Blot: Analyze the expression of common ABC transporters (e.g., MDR1/ABCB1, MRP1/ABCC1, BCRP/ABCG2).
 - Efflux Assays: Use fluorescent substrates of ABC transporters (e.g., Rhodamine 123) to measure their activity.

Troubleshooting Guides

Problem: Inconsistent results in cell viability assays after **Lixumistat hydrochloride** treatment.

Potential Cause	Troubleshooting Step
Cell Seeding Density	Optimize and maintain a consistent cell seeding density for all experiments. High or low confluency can affect drug sensitivity.
Drug Stability	Prepare fresh drug solutions for each experiment. Lixumistat hydrochloride in solution may degrade over time.
Assay Interference	Ensure that the components of your viability assay (e.g., MTT, resazurin) do not interact with Lixumistat hydrochloride. Run a drug-only control (no cells) to check for background signal.
Resistant Subpopulation	A small, resistant subpopulation may be emerging. Consider single-cell cloning to isolate and characterize these clones.

Problem: Difficulty in detecting changes in signaling pathway activation.

Potential Cause	Troubleshooting Step
Timing of Analysis	Signaling pathway activation can be transient. Perform a time-course experiment (e.g., 15 min, 30 min, 1 hr, 6 hr, 24 hr) after Lixumistat hydrochloride treatment to identify the optimal time point for analysis.
Antibody Quality	Validate your primary antibodies for specificity and sensitivity using positive and negative controls.
Basal Pathway Activity	The basal level of pathway activation may be high in your cell line, masking drug-induced changes. Serum-starve the cells before treatment to lower the basal signaling.

Quantitative Data Summary

The following table provides a template for summarizing quantitative data you might generate when investigating **Lixumistat hydrochloride** resistance.

Parameter	Parental (Sensitive) Cells	Resistant Cells	Fold Change
IC50 (μM)	e.g., 0.5 μM	e.g., 5.0 μM	e.g., 10
CXCR4 mRNA (relative expression)	e.g., 1.0	e.g., 4.5	e.g., 4.5
p-AKT/total AKT ratio	e.g., 0.2	e.g., 0.8	e.g., 4.0
p-ERK/total ERK ratio	e.g., 0.3	e.g., 0.9	e.g., 3.0
Basal OCR (pmol/min)	e.g., 150	e.g., 75	e.g., 0.5
Basal ECAR (mpH/min)	e.g., 50	e.g., 100	e.g., 2.0

Experimental Protocols

Western Blot for Phosphorylated Signaling Proteins

- Cell Lysis:
 - Seed sensitive and resistant cells and grow to 70-80% confluency.
 - Treat with **Lixumistat hydrochloride** at the desired concentration and time points.
 - Wash cells with ice-cold PBS and lyse with RIPA buffer containing protease and phosphatase inhibitors.
 - Scrape the cells, transfer to a microfuge tube, and incubate on ice for 30 minutes.
 - Centrifuge at 14,000 rpm for 15 minutes at 4°C. Collect the supernatant.
- Protein Quantification:
 - Determine the protein concentration of each lysate using a BCA assay.
- SDS-PAGE and Transfer:
 - Load 20-30 µg of protein per lane on an SDS-polyacrylamide gel.
 - Run the gel and transfer the proteins to a PVDF membrane.
- Immunoblotting:
 - Block the membrane with 5% BSA or non-fat milk in TBST for 1 hour at room temperature.
 - Incubate with primary antibodies against phosphorylated and total forms of target proteins (e.g., p-AKT, AKT, p-ERK, ERK) overnight at 4°C.
 - Wash the membrane three times with TBST.
 - Incubate with HRP-conjugated secondary antibody for 1 hour at room temperature.
 - Wash three times with TBST.

- Detection:
 - Apply an enhanced chemiluminescence (ECL) substrate and visualize the bands using a chemiluminescence imaging system.
 - Quantify band intensity using image analysis software.

Seahorse XF Cell Mito Stress Test

- Cell Seeding:
 - Seed cells in a Seahorse XF cell culture microplate at a pre-determined optimal density.
 - Allow cells to adhere and grow overnight.
- Assay Preparation:
 - Hydrate the sensor cartridge with Seahorse XF Calibrant overnight at 37°C in a non-CO2 incubator.
 - Wash cells with Seahorse XF base medium supplemented with glucose, pyruvate, and glutamine.
 - Incubate the plate at 37°C in a non-CO2 incubator for 1 hour.
- Compound Loading:
 - Load the injection ports of the sensor cartridge with oligomycin, FCCP, and a mixture of rotenone and antimycin A.
- Data Acquisition:
 - Place the cell culture plate in the Seahorse XF Analyzer and run the Mito Stress Test protocol.
- Data Analysis:
 - Analyze the oxygen consumption rate (OCR) to determine key parameters of mitochondrial function, including basal respiration, ATP production, maximal respiration,

and spare respiratory capacity.

Visualizations

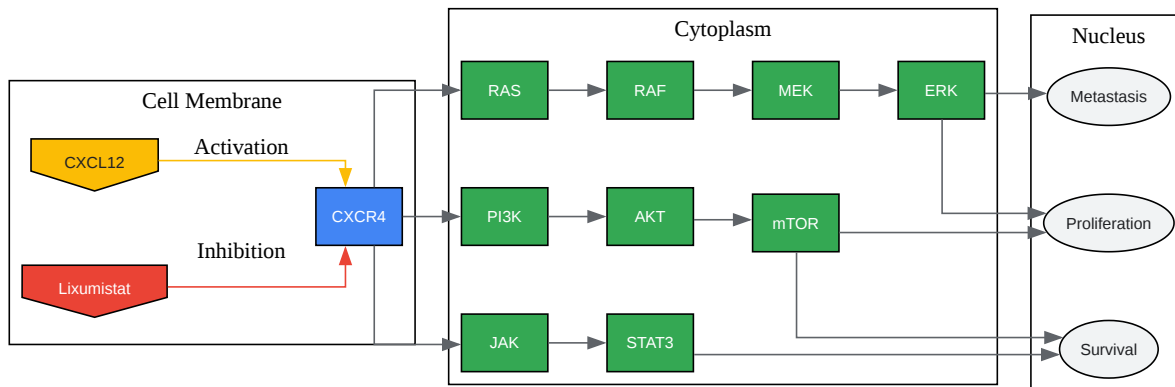

[Click to download full resolution via product page](#)

Caption: CXCR4 signaling pathways potentially bypassed in Lixumistat resistance.



[Click to download full resolution via product page](#)

Caption: Workflow for investigating **Lixumistat hydrochloride** resistance.

Need Custom Synthesis?

BenchChem offers custom synthesis for rare earth carbides and specific isotopic labeling.

Email: info@benchchem.com or [Request Quote Online](#).

References

- [1. mdpi.com \[mdpi.com\]](#)
- [2. mdpi.com \[mdpi.com\]](#)
- [3. Targeting the chemokine receptor CXCR4 for cancer therapies - PMC \[pmc.ncbi.nlm.nih.gov\]](#)
- [4. Lixumistat \(IM156\) in Oncology – Immunomet \[immunomet.com\]](#)
- [5. onclive.com \[onclive.com\]](#)
- [6. Cellular resistance mechanisms in cancer and the new approaches to overcome resistance mechanisms chemotherapy - PMC \[pmc.ncbi.nlm.nih.gov\]](#)
- [7. The Different Mechanisms of Cancer Drug Resistance: A Brief Review - PMC \[pmc.ncbi.nlm.nih.gov\]](#)
- [To cite this document: BenchChem. \[Technical Support Center: Lixumistat Hydrochloride Resistance Mechanisms\]. BenchChem, \[2026\]. \[Online PDF\]. Available at: \[https://www.benchchem.com/product/b12421133/docs#technical-support-center-lixumistat-hydrochloride-resistance-mechanisms\]](#)

Disclaimer & Data Validity:

The information provided in this document is for Research Use Only (RUO) and is strictly not intended for diagnostic or therapeutic procedures. While BenchChem strives to provide accurate protocols, we make no warranties, express or implied, regarding the fitness of this product for every specific experimental setup.

Technical Support: The protocols provided are for reference purposes. Unsure if this reagent suits your experiment?

Need Industrial/Bulk Grade? [Request Custom Synthesis Quote](#)

BenchChem

Our mission is to be the trusted global source of essential and advanced chemicals, empowering scientists and researchers to drive progress in science and industry.

Contact

Address: 3281 E Guasti Rd

Ontario, CA 91761, United States

Phone: (601) 213-4426

Email: info@benchchem.com

[Contact our Ph.D. Support Team for a compatibility check](#)