

Optimizing WW437 Concentration for Cell Culture Experiments: A Technical Support Guide

Author: BenchChem Technical Support Team. **Date:** April 2026

Compound of Interest

Compound Name: WW437
Cat. No.: B12421910

[Get Quote](#)

This technical support center provides researchers, scientists, and drug development professionals with comprehensive guidance on the use of **WW437**, a potent and selective inhibitor of the Wnt signaling pathway, in cell culture experiments. Below you will find troubleshooting guides, frequently asked questions (FAQs), detailed experimental protocols, and visual aids to ensure the successful application of **WW437** in your research.

Frequently Asked Questions (FAQs) & Troubleshooting

This section addresses common issues encountered when using **WW437** in cell culture, providing potential causes and solutions in a straightforward question-and-answer format.

| Question | Potential Cause(s) | Suggested Solution(s) |
|--|--|---|
| <p>Why am I not observing the expected downstream effects of Wnt inhibition (e.g., decreased β-catenin levels)?</p> | <p>1. Suboptimal WW437 Concentration: The concentration may be too low for the specific cell line. 2. High Cell Density: Confluent cultures can sometimes be less responsive to treatment. 3. Incorrect DMSO Concentration: Final DMSO concentration may be too high, causing cellular stress and masking the specific effects of WW437. 4. Degradation of WW437: Improper storage or handling may have led to compound degradation.</p> | <p>1. Perform a Dose-Response Curve: Titrate WW437 across a range of concentrations (e.g., 0.1 nM to 10 μM) to determine the optimal IC50 for your cell line. 2. Optimize Seeding Density: Plate cells at a lower density to ensure they are in the logarithmic growth phase during treatment. 3. Maintain Low DMSO Concentration: Ensure the final concentration of DMSO in the culture medium is below 0.1%. 4. Proper Handling and Storage: Store WW437 stock solutions at -20°C or -80°C in small aliquots to avoid repeated freeze-thaw cycles. Protect from light.</p> |
| <p>My cells are showing signs of toxicity (e.g., detachment, morphological changes, decreased viability) at the recommended concentration.</p> | <p>1. Cell Line Sensitivity: Different cell lines exhibit varying sensitivities to WW437. 2. Prolonged Exposure: Continuous exposure may be toxic to some cell lines. 3. Solvent Toxicity: The final concentration of the solvent (e.g., DMSO) may be too high.</p> | <p>1. Determine the Maximum Tolerated Concentration (MTC): Perform a viability assay (e.g., MTT or trypan blue exclusion) to identify the highest non-toxic concentration for your specific cell line. 2. Optimize Treatment Duration: Reduce the incubation time with WW437. 3. Check Solvent Concentration: Ensure the final solvent concentration is not exceeding recommended limits (typically <0.1% for DMSO).</p> |

| | | |
|---|---|---|
| I'm observing inconsistent results between experiments. | <ol style="list-style-type: none">1. Variability in Cell Passage Number: High passage numbers can lead to genetic drift and altered cellular responses.2. Inconsistent Seeding Density: Variations in the initial number of cells can affect the outcome.3. Inconsistent WW437 Preparation: Errors in diluting the stock solution can lead to different final concentrations. | <ol style="list-style-type: none">1. Use Low Passage Cells: Maintain a consistent and low passage number for your cell line.2. Standardize Seeding Protocol: Ensure a consistent number of viable cells are seeded for each experiment.3. Prepare Fresh Dilutions: Prepare fresh working solutions of WW437 from a stock aliquot for each experiment. |
|---|---|---|

| | | |
|---|--|--|
| WW437 precipitated in my cell culture medium. | <ol style="list-style-type: none">1. Poor Solubility: The concentration of WW437 may exceed its solubility limit in the culture medium.2. Interaction with Media Components: Components in the serum or media may interact with WW437, causing it to precipitate.^[1] | <ol style="list-style-type: none">1. Check Solubility Limits: Refer to the manufacturer's instructions for the solubility of WW437 in aqueous solutions.2. Modify Dilution Method: When diluting the DMSO stock, add it to the medium while gently vortexing to ensure rapid and even dispersion.^[1] Consider using a serum-free medium for the duration of the treatment if compatible with your cells.^[1] |
|---|--|--|

Experimental Protocols

Below are detailed methodologies for key experiments involving **WW437**.

Determination of IC50 using MTT Assay

This protocol outlines the steps to determine the half-maximal inhibitory concentration (IC50) of **WW437** on cell viability.

Materials:

- **WW437** stock solution (e.g., 10 mM in DMSO)
- Target cell line
- Complete cell culture medium
- 96-well cell culture plates
- MTT (3-(4,5-dimethylthiazol-2-yl)-2,5-diphenyltetrazolium bromide) solution (5 mg/mL in PBS)
- DMSO
- Multichannel pipette
- Plate reader (570 nm)

Procedure:

- Seed cells into a 96-well plate at a density of 5,000-10,000 cells/well in 100 μ L of complete medium and incubate for 24 hours.
- Prepare serial dilutions of **WW437** in complete medium. A common starting range is 0.01, 0.1, 1, 10, 100, 1000, and 10000 nM. Include a vehicle control (medium with the same concentration of DMSO as the highest **WW437** concentration).
- Remove the old medium from the cells and add 100 μ L of the prepared **WW437** dilutions or vehicle control to the respective wells.
- Incubate the plate for the desired treatment duration (e.g., 48 or 72 hours).
- Add 20 μ L of MTT solution to each well and incubate for 4 hours at 37°C.
- Carefully remove the medium and add 150 μ L of DMSO to each well to dissolve the formazan crystals.
- Measure the absorbance at 570 nm using a plate reader.

- Calculate the percentage of cell viability for each concentration relative to the vehicle control and plot a dose-response curve to determine the IC50.

Western Blot Analysis of β -catenin Levels

This protocol describes how to assess the effect of **WW437** on the protein levels of β -catenin, a key downstream target of the Wnt signaling pathway.

Materials:

- **WW437**-treated and control cell lysates
- RIPA buffer with protease and phosphatase inhibitors
- BCA protein assay kit
- SDS-PAGE gels
- Transfer buffer
- PVDF membrane
- Blocking buffer (e.g., 5% non-fat milk or BSA in TBST)
- Primary antibodies (anti- β -catenin, anti- β -actin or anti-GAPDH)
- HRP-conjugated secondary antibody
- Chemiluminescent substrate
- Imaging system

Procedure:

- Treat cells with the desired concentration of **WW437** and a vehicle control for the specified time.
- Lyse the cells in RIPA buffer and quantify the protein concentration using a BCA assay.

- Denature equal amounts of protein from each sample by boiling in Laemmli buffer.
- Separate the proteins by SDS-PAGE and transfer them to a PVDF membrane.
- Block the membrane with blocking buffer for 1 hour at room temperature.
- Incubate the membrane with the primary antibody against β -catenin overnight at 4°C.
- Wash the membrane with TBST and incubate with the HRP-conjugated secondary antibody for 1 hour at room temperature.
- Wash the membrane again and detect the signal using a chemiluminescent substrate and an imaging system.
- Normalize the β -catenin band intensity to a loading control (β -actin or GAPDH).

Signaling Pathways and Workflows

Visual representations of the Wnt signaling pathway and experimental workflows can aid in understanding the mechanism of action of **WW437** and in experimental design.

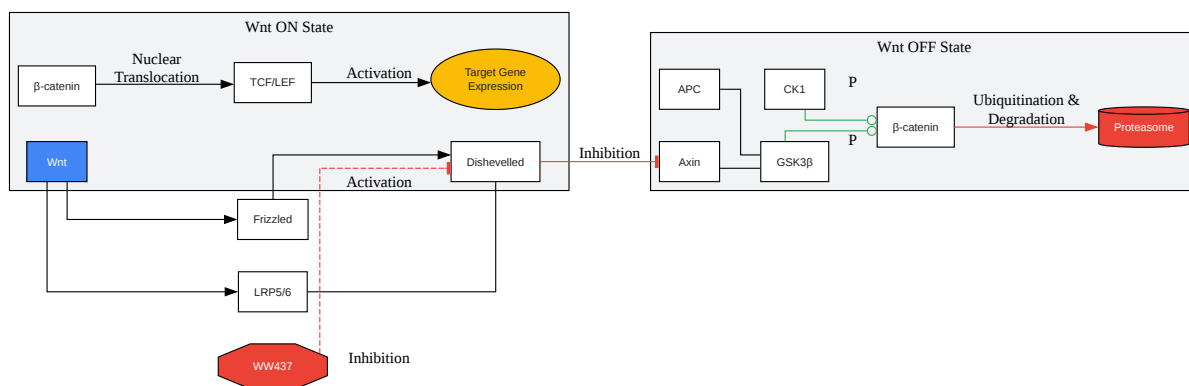

[Click to download full resolution via product page](#)

Caption: The Wnt signaling pathway with and without Wnt ligand, and the inhibitory action of **WW437**.

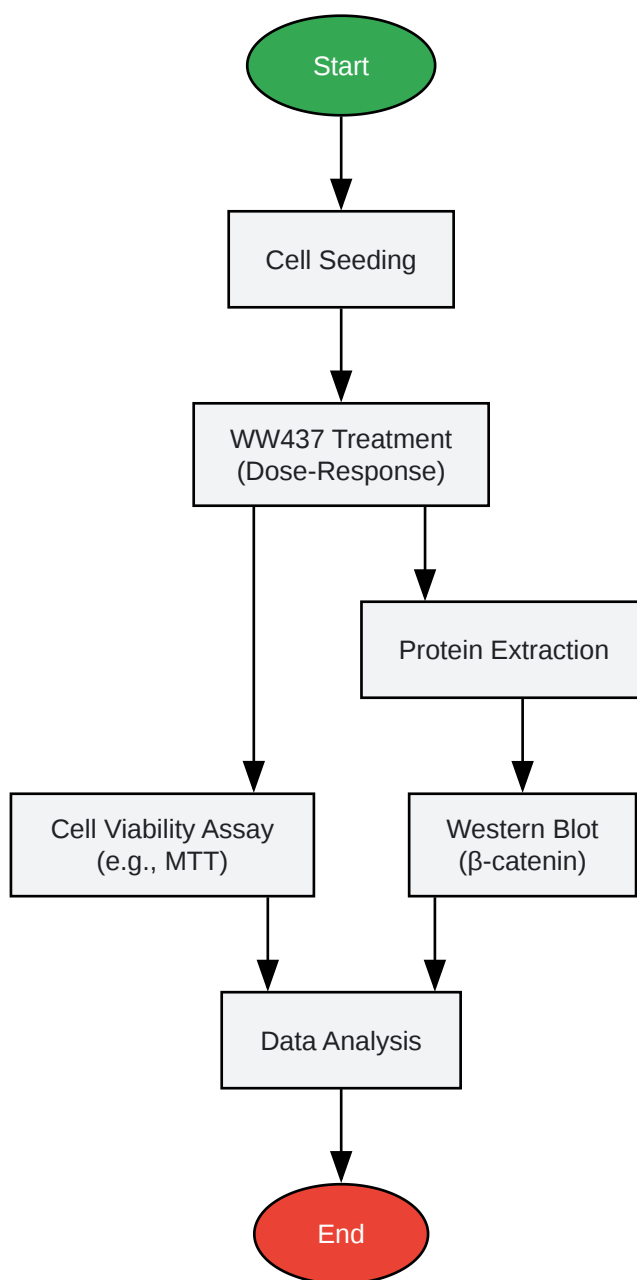

[Click to download full resolution via product page](#)

Caption: A typical experimental workflow for evaluating the effects of **WW437** on cell viability and Wnt signaling.

Need Custom Synthesis?

BenchChem offers custom synthesis for rare earth carbides and specific isotopic labeling.

Email: info@benchchem.com or [Request Quote Online](#).

References

- [1. benchchem.com \[benchchem.com\]](#)
- To cite this document: BenchChem. [Optimizing WW437 Concentration for Cell Culture Experiments: A Technical Support Guide]. BenchChem, [2026]. [Online PDF]. Available at: [<https://www.benchchem.com/product/b12421910/docs#optimizing-ww437-concentration-for-cell-culture-experiments-a-technical-support-guide>]

Disclaimer & Data Validity:

The information provided in this document is for Research Use Only (RUO) and is strictly not intended for diagnostic or therapeutic procedures. While BenchChem strives to provide accurate protocols, we make no warranties, express or implied, regarding the fitness of this product for every specific experimental setup.

Technical Support: The protocols provided are for reference purposes. Unsure if this reagent suits your experiment?

Need Industrial/Bulk Grade? [Request Custom Synthesis Quote](#)

BenchChem

Our mission is to be the trusted global source of essential and advanced chemicals, empowering scientists and researchers to drive progress in science and industry.

Contact

Address: 3281 E Guasti Rd
Ontario, CA 91761, United States
Phone: (601) 213-4426
Email: info@benchchem.com

[Contact our Ph.D. Support Team for a compatibility check](#)

