

In Vivo Efficacy of OXPHOS Inhibitors: A Comparative Guide

Author: BenchChem Technical Support Team. **Date:** May 2026

Compound of Interest

Compound Name: *Lixumistat hydrochloride*

Cat. No.: *B12421133*

[Get Quote](#)

For Researchers, Scientists, and Drug Development Professionals

The landscape of cancer metabolism research has identified oxidative phosphorylation (OXPHOS) as a critical pathway for tumor cell survival and proliferation, making it a prime target for therapeutic intervention. A variety of small molecule inhibitors targeting different complexes of the electron transport chain have been developed and evaluated in preclinical in vivo models. This guide provides an objective comparison of the in vivo efficacy of several prominent OXPHOS inhibitors, supported by experimental data from published studies.

Quantitative Efficacy Comparison of OXPHOS Inhibitors

The following tables summarize the in vivo anti-tumor efficacy of four key OXPHOS inhibitors: IACS-010759, BAY 87-2243, Metformin, and Devimistat (CPI-613). It is important to note that the data presented is compiled from different studies using various tumor models and experimental conditions. Therefore, direct comparison of absolute efficacy should be interpreted with caution.

Inhibitor	Target	Cancer Model	Animal Model	Dosing Regimen	Key Efficacy Readouts	Reference
IACS-010759	Complex I	Neuroblastoma (SK-N-AS Xenograft)	Nude Mice	5 or 10 mg/kg, p.o., daily	Dose-dependent tumor growth inhibition. The higher 10 mg/kg dose resulted in a greater response.	[1]
Complex I	Acute Myeloid Leukemia (AML Xenograft)	Nude Mice	15 mg/kg, p.o., daily	100% survival up to 60 days with no significant change in body weight.	[2]	
BAY 87-2243	Complex I	Lung Cancer (H460 Xenograft)	Nude Mice	0.5, 1, 2, and 4 mg/kg, p.o., daily for 21 days	Dose-dependent reduction in tumor weight.[3] [4]	[3][4]
Complex I	Melanoma (BRAF mutant xenografts)	Nude Mice	9 mg/kg, p.o., daily	Significant reduction in tumor size and weight across	[5]	

				multiple melanoma xenograft models.[5]		
Metformin	Complex I (mild inhibitor)	Osteosarcoma (KHOS/NP Xenograft)	BALB/c Nude Mice	~12 mg/day/mouse use for 4 weeks	Significant inhibition of tumor growth; at day 27, the tumor volume fold increase was 48% of the control.[6]	[6]
Complex I (mild inhibitor)	Pancreatic Cancer (PANC-1 Xenograft)	Nude Mice	50-250 mg/kg, i.p., daily	Dose-dependent inhibition of tumor growth, with maximal effect at 200 mg/kg. [7]		[7]
Devimistat (CPI-613)	PDH & α -KGDH	Colorectal Cancer (Xenograft)	Nude Mice	Not specified	Showed antitumor activity and synergized with irinotecan, resulting in prolonged survival and enhanced	[8][9]

therapeutic
 efficacy.[8]
[\[9\]](#)

PDH & α -KGDH	Pancreatic Cancer (Xenograft)	Nude Mice	Not specified	Demonstrated strong antitumor activity in vivo with low side-effect toxicity.[10]	[10]
----------------------	-------------------------------	-----------	---------------	---	----------------------

Signaling Pathways and Experimental Workflows

To visually represent the mechanisms of action and experimental processes, the following diagrams are provided.

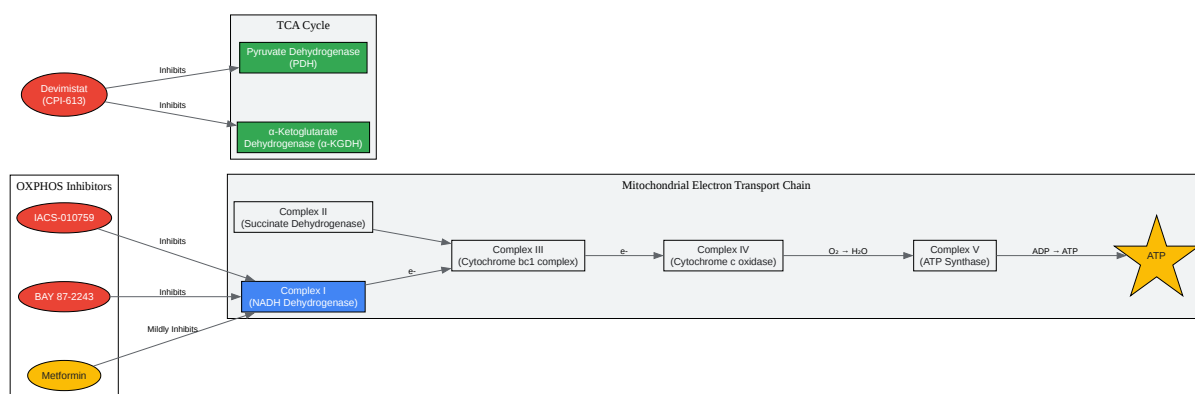

[Click to download full resolution via product page](#)

Mechanism of action of various OXPPOS inhibitors.

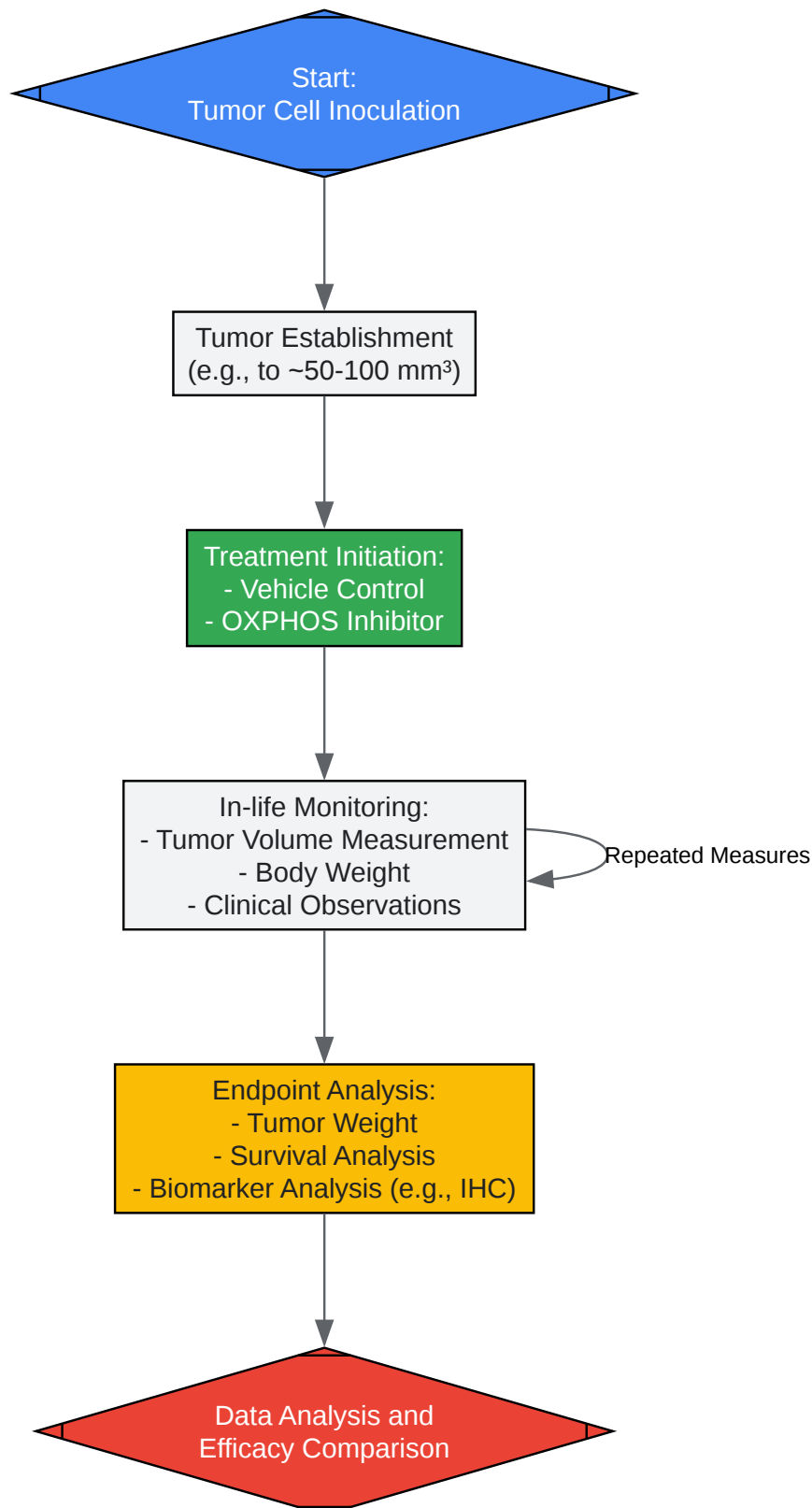

[Click to download full resolution via product page](#)

A generalized workflow for in vivo efficacy studies.

Detailed Experimental Protocols

The following are generalized protocols for in vivo xenograft studies based on the methodologies reported in the referenced literature. Specific details may vary between studies.

Animal Models and Husbandry

- **Animal Strain:** Immunocompromised mice (e.g., BALB/c nude, NOD-SCID) are typically used for xenograft studies to prevent rejection of human tumor cells.
- **Housing:** Animals are housed in specific pathogen-free (SPF) conditions with ad libitum access to food and water. All procedures are conducted in accordance with institutional animal care and use committee (IACUC) guidelines.

Tumor Cell Culture and Inoculation

- **Cell Lines:** Human cancer cell lines (e.g., H460 lung cancer, SK-N-AS neuroblastoma, KHOS/NP osteosarcoma) are cultured in appropriate media supplemented with fetal bovine serum and antibiotics.
- **Inoculation:** A specific number of cells (typically 1×10^6 to 5×10^6) suspended in a suitable medium (e.g., PBS or Matrigel) are injected subcutaneously into the flank of the mice.

Drug Formulation and Administration

- **IACS-010759:** Formulated in a suitable vehicle (e.g., 0.5% methylcellulose) for oral gavage (p.o.).[\[11\]](#)
- **BAY 87-2243:** Formulated in a vehicle such as a solution of ethanol, Solutol, and water for oral gavage (p.o.).[\[3\]](#)
- **Metformin:** Can be administered via intraperitoneal (i.p.) injection or dissolved in drinking water.[\[6\]](#)[\[7\]](#)
- **Devimistat (CPI-613):** Typically formulated for intravenous (i.v.) or intraperitoneal (i.p.) administration.

In Vivo Efficacy Study Design

- Tumor Growth Monitoring: Tumors are allowed to reach a palpable size (e.g., 50-100 mm³) before the initiation of treatment.
- Treatment Groups: Animals are randomized into control (vehicle) and treatment groups.
- Dosing: Drugs are administered according to a predetermined schedule (e.g., daily, 5 days a week).
- Measurements: Tumor dimensions are measured regularly (e.g., twice weekly) using calipers, and tumor volume is calculated using the formula: $(\text{Length} \times \text{Width}^2)/2$. Animal body weight is also monitored as an indicator of toxicity.[11]
- Endpoint: The study is terminated when tumors in the control group reach a predetermined size, or at a specified time point. Tumors are then excised and weighed. For survival studies, animals are monitored until a defined endpoint (e.g., tumor volume exceeding a certain limit, significant weight loss).

Data and Statistical Analysis

- Tumor growth curves are plotted as the mean tumor volume \pm standard error of the mean (SEM) for each group over time.
- Statistical significance between treatment and control groups is determined using appropriate statistical tests (e.g., t-test, ANOVA).
- Survival data is often presented as Kaplan-Meier curves and analyzed using the log-rank test.

Conclusion

The preclinical in vivo data for IACS-010759, BAY 87-2243, Metformin, and Devimistat demonstrate that targeting OXPHOS is a promising anti-cancer strategy. IACS-010759 and BAY 87-2243 appear to be highly potent Complex I inhibitors with significant anti-tumor activity in various models.[1][2][3][5] Metformin, a milder Complex I inhibitor, also shows efficacy, particularly at higher doses.[6][7] Devimistat, with its unique mechanism of targeting PDH and α -KGDH, has shown promise both as a single agent and in combination therapies.[8][9][10]

While the presented data provides a valuable comparative overview, it is crucial to acknowledge the limitations of cross-study comparisons. Future head-to-head in vivo studies in standardized models would be invaluable for a more definitive assessment of the relative efficacy and therapeutic potential of these different OXPHOS inhibitors.

Need Custom Synthesis?

BenchChem offers custom synthesis for rare earth carbides and specific isotopic labeling.

Email: info@benchchem.com or [Request Quote Online](#).

References

- [1. researchgate.net \[researchgate.net\]](#)
- [2. tandfonline.com \[tandfonline.com\]](#)
- [3. BAY 87-2243, a highly potent and selective inhibitor of hypoxia-induced gene activation has antitumor activities by inhibition of mitochondrial complex I - PMC \[pmc.ncbi.nlm.nih.gov\]](#)
- [4. selleckchem.com \[selleckchem.com\]](#)
- [5. scispace.com \[scispace.com\]](#)
- [6. Metformin displays in vitro and in vivo antitumor effect against osteosarcoma - PMC \[pmc.ncbi.nlm.nih.gov\]](#)
- [7. Metformin Inhibits the Growth of Human Pancreatic Cancer Xenografts - PMC \[pmc.ncbi.nlm.nih.gov\]](#)
- [8. The Mitochondrial Disruptor Devimistat \(CPI-613\) Synergizes with Genotoxic Anticancer Drugs in Colorectal Cancer Therapy in a Bim-Dependent Manner - PubMed \[pubmed.ncbi.nlm.nih.gov\]](#)
- [9. aacrjournals.org \[aacrjournals.org\]](#)
- [10. researchgate.net \[researchgate.net\]](#)
- [11. benchchem.com \[benchchem.com\]](#)
- To cite this document: BenchChem. [In Vivo Efficacy of OXPHOS Inhibitors: A Comparative Guide]. BenchChem, [2026]. [Online PDF]. Available at: [\[https://www.benchchem.com/product/b12421133/docs#in-vivo-efficacy-of-oxphos-inhibitors-a-comparative-guide\]](https://www.benchchem.com/product/b12421133/docs#in-vivo-efficacy-of-oxphos-inhibitors-a-comparative-guide)

Disclaimer & Data Validity:

The information provided in this document is for Research Use Only (RUO) and is strictly not intended for diagnostic or therapeutic procedures. While BenchChem strives to provide accurate protocols, we make no warranties, express or implied, regarding the fitness of this product for every specific experimental setup.

Technical Support: The protocols provided are for reference purposes. Unsure if this reagent suits your experiment?

Need Industrial/Bulk Grade? [Request Custom Synthesis Quote](#)

BenchChem

Our mission is to be the trusted global source of essential and advanced chemicals, empowering scientists and researchers to drive progress in science and industry.

Contact

Address: 3281 E Guasti Rd
Ontario, CA 91761, United States
Phone: (601) 213-4426
Email: info@benchchem.com

[Contact our Ph.D. Support Team for a compatibility check](#)