

In-Depth Technical Guide to GW2580-d6: Physical, Chemical, and Biological Properties

Author: BenchChem Technical Support Team. **Date:** April 2026

Compound of Interest

Compound Name: GW2580-d6

Cat. No.: B12421085

[Get Quote](#)

For Researchers, Scientists, and Drug Development Professionals

This technical guide provides a comprehensive overview of the physical, chemical, and biological properties of **GW2580-d6**, a deuterated analog of the potent and selective c-Fms kinase inhibitor, GW2580. This document is intended to serve as a core resource for researchers utilizing **GW2580-d6** in drug development, signaling pathway analysis, and various experimental models.

Core Physical and Chemical Properties

GW2580-d6 is the deuterium-labeled version of GW2580, an orally bioavailable small molecule. The primary application of **GW2580-d6** is as an internal standard for quantitative analysis by Nuclear Magnetic Resonance (NMR), Gas Chromatography-Mass Spectrometry (GC-MS), or Liquid Chromatography-Mass Spectrometry (LC-MS).^[1] Deuteration can also potentially influence the pharmacokinetic and metabolic profiles of the drug.^[1]

Table 1: Physical and Chemical Properties of GW2580 and **GW2580-d6**

Property	GW2580	GW2580-d6
Chemical Name	5-((3-Methoxy-4-((4-methoxybenzyl)oxy)benzyl)pyrimidine-2,4-diamine	5-((3-Methoxy-4-((4-methoxybenzyl)oxy)benzyl)pyrimidine-2,4-diamine)-d6
Molecular Formula	C ₂₀ H ₂₂ N ₄ O ₃	C ₂₀ H ₁₆ D ₆ N ₄ O ₃
Molecular Weight	366.41 g/mol	372.45 g/mol
CAS Number	870483-87-7	2733770-48-2[1]
Appearance	White to beige solid[2]	Data not available
Purity	≥98% (HPLC)	≥98%
Melting Point	Data not available	Data not available
pKa	Data not available	Data not available

Table 2: Solubility Data for GW2580

Solvent	Concentration	Notes
DMSO	18.32 mg/mL (50 mM)	Warmed solution may be necessary.[2][3]
Ethanol	Insoluble	

Spectroscopic Data for GW2580-d6

Spectroscopic data is crucial for the confirmation of the chemical structure and purity of **GW2580-d6**. Commercially available **GW2580-d6** is typically accompanied by a Certificate of Analysis (CoA), Proton Nuclear Magnetic Resonance (¹H NMR), and Liquid Chromatography-Mass Spectrometry (LC-MS) data.

While the complete spectral data files are available from commercial suppliers, a summary of expected findings is presented below.

- ^1H NMR: The proton NMR spectrum of **GW2580-d6** is expected to be similar to that of GW2580, with the notable absence of signals corresponding to the six deuterated positions. The precise location of deuterium labeling is critical for its use as an internal standard and should be confirmed from the supplier's documentation.
- LC-MS: The mass spectrum of **GW2580-d6** will show a molecular ion peak corresponding to its higher molecular weight due to the presence of six deuterium atoms. This distinct mass-to-charge ratio allows for its clear separation and quantification from the non-deuterated form in biological matrices.

Biological Activity and Mechanism of Action

GW2580 is a potent and selective inhibitor of the c-Fms kinase, also known as the Colony-Stimulating Factor 1 Receptor (CSF-1R).[4] It acts as an ATP-competitive inhibitor, binding to the kinase domain of the receptor and preventing its autophosphorylation and the subsequent activation of downstream signaling pathways.[4][5] GW2580 completely inhibits human c-FMS kinase in vitro at a concentration of 0.06 μM .[1]

The primary biological consequence of c-Fms/CSF-1R inhibition by GW2580 is the suppression of the survival, proliferation, and differentiation of mononuclear phagocytes, including monocytes, macrophages, and osteoclasts.[6]

Signaling Pathway

The binding of Colony-Stimulating Factor 1 (CSF-1) or Interleukin-34 (IL-34) to the c-Fms receptor triggers its dimerization and autophosphorylation. This initiates a cascade of intracellular signaling events that are crucial for the function of myeloid cells. GW2580 blocks these downstream signaling pathways.

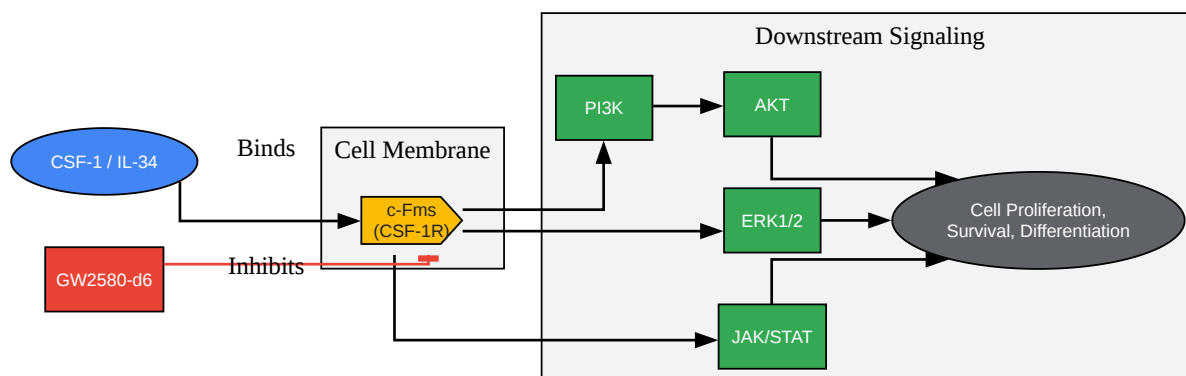

[Click to download full resolution via product page](#)

Caption: CSF-1R Signaling Pathway Inhibition by **GW2580-d6**.

Experimental Protocols

This section provides an overview of key experimental methodologies involving GW2580. For the use of **GW2580-d6** as an internal standard, it would be incorporated into the sample preparation phase of the respective analytical protocol.

In Vitro c-Fms Kinase Assay

This protocol outlines a method for determining the inhibitory activity of GW2580 on c-Fms kinase.

Materials:

- Recombinant human c-Fms kinase
- ATP
- Peptide substrate (e.g., Biotin-EAIYAPFAKKK-NH₂)
- GW2580

- Assay buffer (e.g., 50 mM MOPS, pH 7.5, 15 mM MgCl₂, 7.5 mM DTT, 75 mM NaCl)
- [γ -³³P]ATP
- Phosphocellulose filter plates
- Scintillation counter

Procedure:

- Prepare a reaction mixture containing the assay buffer, peptide substrate, ATP, and [γ -³³P]ATP.
- Add serial dilutions of GW2580 or vehicle control (DMSO) to the reaction mixture.
- Initiate the kinase reaction by adding the recombinant c-Fms kinase.
- Incubate the reaction at 30°C for a defined period (e.g., 40 minutes).
- Stop the reaction by adding an equal volume of 0.5% phosphoric acid.
- Transfer the reaction mixture to a phosphocellulose filter plate to capture the phosphorylated substrate.
- Wash the filter plate multiple times with 0.5% phosphoric acid to remove unincorporated [γ -³³P]ATP.
- Add scintillation fluid to each well and measure the radioactivity using a scintillation counter.
- Calculate the percentage of kinase inhibition for each GW2580 concentration and determine the IC₅₀ value.^[7]

Quantification of GW2580 in Plasma by LC-MS/MS

The following provides a general workflow for the quantification of GW2580 in plasma, for which **GW2580-d6** would serve as an ideal internal standard. Specific parameters would require optimization and validation.

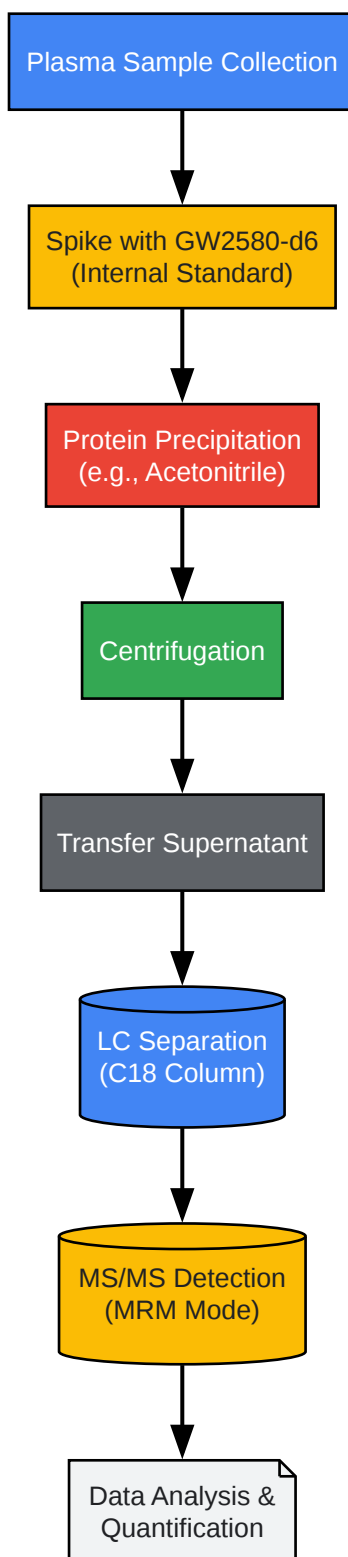

[Click to download full resolution via product page](#)

Caption: General Workflow for LC-MS/MS Quantification of GW2580.

Methodological Considerations:

- **Sample Preparation:** Protein precipitation with a solvent like acetonitrile is a common method for extracting small molecules from plasma.[8]
- **Internal Standard:** **GW2580-d6** should be added to samples and calibration standards at a fixed concentration at the beginning of the sample preparation process to correct for variability in extraction and instrument response.
- **Chromatography:** A reverse-phase C18 column is typically used for the separation of small molecules like GW2580. A gradient elution with mobile phases such as water and acetonitrile containing a small amount of formic acid is common.
- **Mass Spectrometry:** Detection is performed using a triple quadrupole mass spectrometer in Multiple Reaction Monitoring (MRM) mode. Specific precursor-to-product ion transitions for both GW2580 and **GW2580-d6** need to be determined and optimized for sensitivity and specificity.
- **Validation:** The method should be fully validated according to regulatory guidelines, including assessments of linearity, accuracy, precision, selectivity, recovery, and stability.[8]

In Vivo Studies

GW2580 has been utilized in numerous in vivo models to investigate the role of c-Fms/CSF-1R signaling in various diseases.

Table 3: Examples of In Vivo Applications of GW2580

Disease Model	Species	Dosing	Key Findings
Arthritis	Rat	50 mg/kg, twice daily	Inhibits joint connective tissue and bone destruction.[4]
Cancer (Myeloid Tumor)	Mouse	80 mg/kg, oral	Completely blocks the growth of CSF-1-dependent tumor cells.[4]
Neuroinflammation	Mouse	Not specified	Reduces microglial proliferation and is neuroprotective.

General Protocol for an In Vivo Efficacy Study:

- **Animal Model:** Select an appropriate animal model for the disease of interest.
- **Dosing Formulation:** Prepare a suitable vehicle for oral administration of GW2580 (e.g., 0.5% methylcellulose).
- **Dose and Schedule:** Determine the optimal dose and dosing frequency based on previous studies or pilot experiments.
- **Treatment Groups:** Include a vehicle control group and one or more GW2580 treatment groups.
- **Outcome Measures:** Monitor relevant endpoints such as tumor volume, clinical scores of disease, or specific biomarkers.
- **Pharmacokinetic/Pharmacodynamic Analysis:** At the end of the study, plasma and tissue samples can be collected to measure GW2580 concentrations (using an LC-MS/MS method with **GW2580-d6** as an internal standard) and assess downstream target engagement.

Storage and Handling

- **Solid Form:** Store at -20°C for long-term stability.

- Solutions: Stock solutions, typically in DMSO, should be stored at -80°C for up to 6 months or at -20°C for up to 1 month.^[1] Avoid repeated freeze-thaw cycles.

This technical guide provides a foundational understanding of **GW2580-d6** for research and development purposes. For specific applications, further optimization and validation of experimental protocols are recommended.

Need Custom Synthesis?

BenchChem offers custom synthesis for rare earth carbides and specific isotopic labeling.

Email: info@benchchem.com or [Request Quote Online](#).

References

- 1. [medchemexpress.com](https://www.medchemexpress.com) [[medchemexpress.com](https://www.medchemexpress.com)]
- 2. [GW2580, \[³H\] - Novandi Chemistry AB - Radiosynthesis Expertise](#) [[novandi.se](https://www.novandi.se)]
- 3. [GW-2580 | C₂₀H₂₂N₄O₃ | CID 11617559 - PubChem](#) [pubchem.ncbi.nlm.nih.gov]
- 4. [medchemexpress.com](https://www.medchemexpress.com) [[medchemexpress.com](https://www.medchemexpress.com)]
- 5. [apexbt.com](https://www.apexbt.com) [[apexbt.com](https://www.apexbt.com)]
- 6. [axonmedchem.com](https://www.axonmedchem.com) [[axonmedchem.com](https://www.axonmedchem.com)]
- 7. [selleckchem.com](https://www.selleckchem.com) [[selleckchem.com](https://www.selleckchem.com)]
- 8. Development and validation of a LC-MS/MS method for the quantification of the checkpoint kinase 1 inhibitor SRA737 in human plasma - PubMed [pubmed.ncbi.nlm.nih.gov]
- To cite this document: BenchChem. [In-Depth Technical Guide to GW2580-d6: Physical, Chemical, and Biological Properties]. BenchChem, [2026]. [Online PDF]. Available at: [<https://www.benchchem.com/product/b12421085/docs#in-depth-technical-guide-to-gw2580-d6-physical-chemical-and-biological-properties>]

Disclaimer & Data Validity:

The information provided in this document is for Research Use Only (RUO) and is strictly not intended for diagnostic or therapeutic procedures. While BenchChem strives to provide

accurate protocols, we make no warranties, express or implied, regarding the fitness of this product for every specific experimental setup.

Technical Support: The protocols provided are for reference purposes. Unsure if this reagent suits your experiment?

Need Industrial/Bulk Grade? [Request Custom Synthesis Quote](#)

BenchChem

Our mission is to be the trusted global source of essential and advanced chemicals, empowering scientists and researchers to drive progress in science and industry.

Contact

Address: 3281 E Guasti Rd

Ontario, CA 91761, United States

Phone: (601) 213-4426

Email: info@benchchem.com

[Contact our Ph.D. Support Team for a compatibility check](#)