

Comparative Guide to Phospho-CSF-1R Antibody Validation and Cross-Reactivity

Author: BenchChem Technical Support Team. **Date:** April 2026

Compound of Interest

Compound Name: GW2580-d6

Cat. No.: B12421085

[Get Quote](#)

This guide provides a comparative analysis of commercially available phospho-CSF-1R (p-CSF-1R) antibodies, offering researchers objective data to select the most suitable reagents for their specific applications. The focus is on cross-reactivity, specificity, and performance across various immunoassays.

Introduction to CSF-1R and its Phosphorylation

The Colony-Stimulating Factor 1 Receptor (CSF-1R), also known as c-FMS, is a receptor tyrosine kinase essential for the proliferation, differentiation, and survival of macrophages and their progenitors. Upon binding its ligands, CSF-1 or IL-34, the receptor dimerizes, leading to autophosphorylation at multiple tyrosine residues within its cytoplasmic domain. This phosphorylation cascade creates docking sites for downstream signaling proteins, activating critical pathways like PI3K/AKT and MAPK/ERK, which regulate cell function. The phosphorylation status of CSF-1R is a direct indicator of its activation state, making phospho-specific antibodies crucial tools in cancer and immunology research.

Comparative Analysis of Phospho-CSF-1R Antibodies

The selection of a reliable p-CSF-1R antibody is critical for accurate and reproducible results. The following table summarizes the performance and validation data for commonly used antibody clones targeting key phosphorylation sites.

Target Phospho-Site	Clone / Catalog #	Host	Reactivity	Validated Applications	Specificity Notes
Tyr723	D2E3G	Rabbit	Human, Mouse	WB, IHC, IF, Flow	Highly specific for p-Tyr723, a key activation loop site. Minimal cross-reactivity with other phosphorylated receptors.
Tyr809	C3C1	Rabbit	Human, Mouse	WB, IP	Targets a phosphorylation site within the kinase domain, crucial for catalytic activity.
Tyr561	EP863Y	Rabbit	Human	WB, IHC	Recognizes a juxtamembrane domain site involved in recruiting PI3K.
Pan-Phospho-Tyrosine	4G10	Mouse	Broad	WB, IP	Not specific to CSF-1R but can be used post-immunoprecipitation of total CSF-1R

to assess
overall
phosphorylati
on.

This table is a representative summary. Researchers should always consult the latest manufacturer datasheets for complete validation data.

Signaling Pathway and Experimental Workflow

To aid in experimental design, the following diagrams illustrate the CSF-1R signaling cascade and a standard workflow for antibody validation.

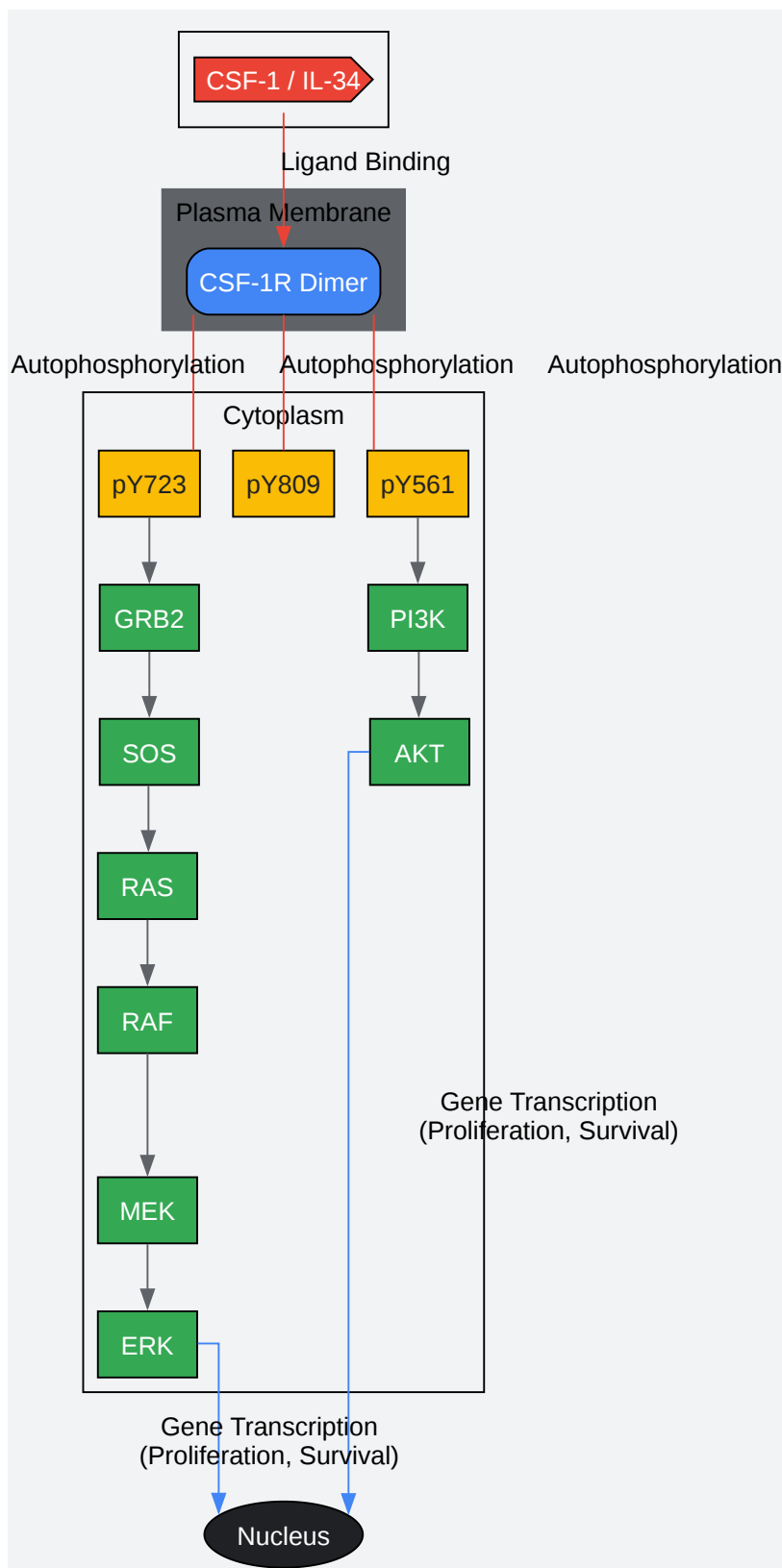

[Click to download full resolution via product page](#)

Caption: CSF-1R signaling pathway activation.

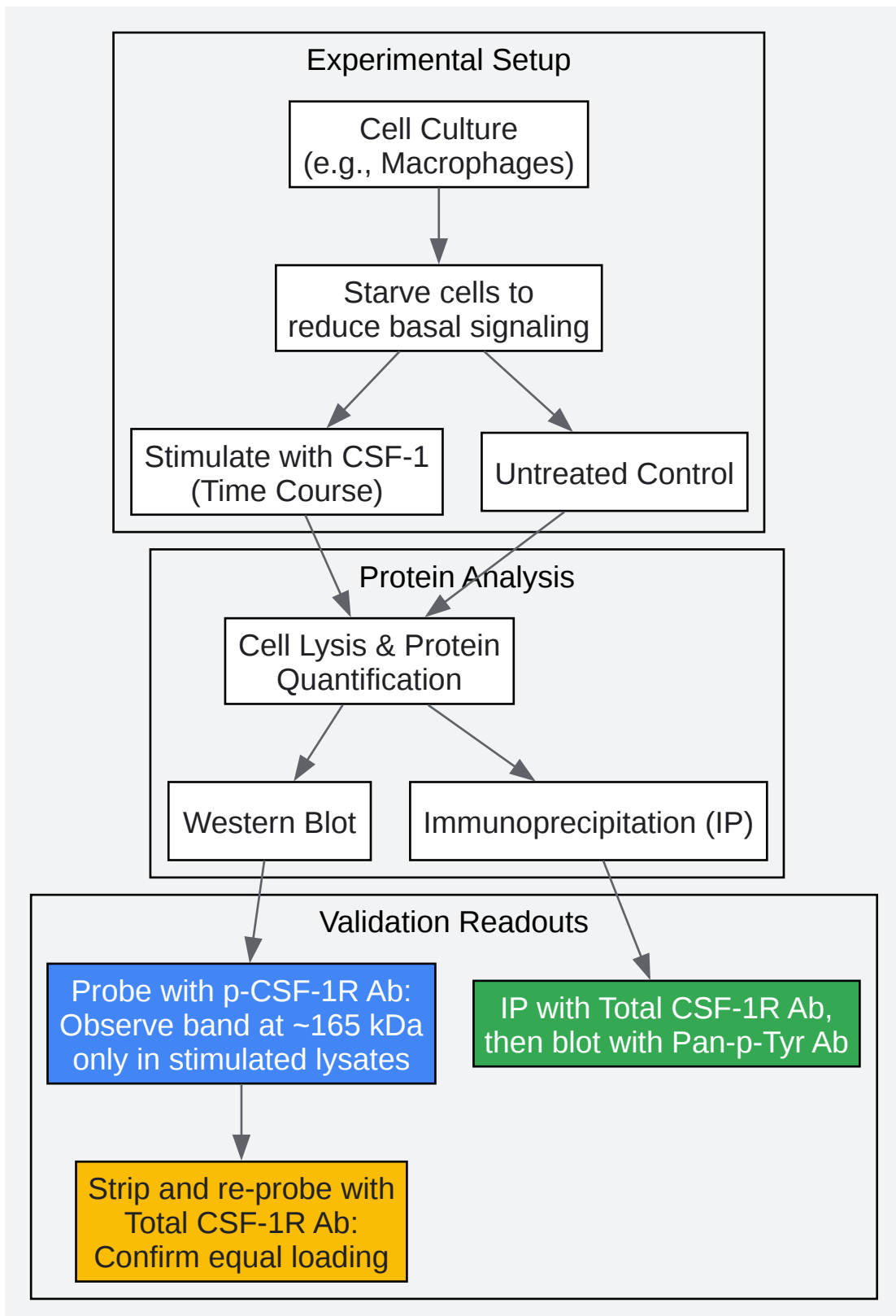

[Click to download full resolution via product page](#)

Caption: Workflow for p-CSF-1R antibody validation.

Experimental Protocols

Reproducibility starts with a robust protocol. The following methods are provided as a baseline for the validation of p-CSF-1R antibodies.

Protocol 1: Western Blotting for p-CSF-1R (Tyr723)

- Cell Culture and Stimulation:
 - Plate bone marrow-derived macrophages (BMDMs) or a human monocytic cell line (e.g., THP-1) at $1-2 \times 10^6$ cells/well in a 6-well plate.
 - Once adherent, serum-starve the cells overnight in a medium containing 0.5% FBS.
 - Prepare a negative control (untreated) and treat the remaining wells with 100 ng/mL recombinant human CSF-1 for various time points (e.g., 0, 5, 15, 30 minutes).
- Lysis and Protein Quantification:
 - Immediately place plates on ice and wash cells once with ice-cold PBS containing phosphatase inhibitors (e.g., sodium orthovanadate).
 - Lyse cells in 150 μ L of RIPA buffer supplemented with protease and phosphatase inhibitor cocktails.
 - Scrape cells, transfer lysate to a microfuge tube, and centrifuge at $14,000 \times g$ for 15 minutes at 4°C .
 - Transfer the supernatant to a new tube and determine protein concentration using a BCA assay.
- SDS-PAGE and Western Blotting:
 - Normalize protein concentrations and prepare samples with Laemmli sample buffer. Boil at 95°C for 5 minutes.
 - Load 20-30 μ g of protein per lane onto an 8% Tris-glycine polyacrylamide gel.

- Perform electrophoresis and transfer proteins to a PVDF membrane.
- Block the membrane for 1 hour at room temperature with 5% Bovine Serum Albumin (BSA) in Tris-Buffered Saline with 0.1% Tween-20 (TBST).
- Incubate the membrane with the primary antibody (e.g., anti-p-CSF-1R Tyr723, diluted in 5% BSA/TBST) overnight at 4°C with gentle agitation.
- Wash the membrane 3x for 10 minutes each with TBST.
- Incubate with an HRP-conjugated secondary antibody for 1 hour at room temperature.
- Wash again as in the previous step.
- Apply an enhanced chemiluminescence (ECL) substrate and visualize the signal using a digital imager. The expected band for CSF-1R is approximately 165 kDa.

Protocol 2: Immunohistochemistry (IHC) for p-CSF-1R

- Tissue Preparation:
 - Fix formalin-fixed, paraffin-embedded (FFPE) tissue sections.
 - Deparaffinize sections with xylene and rehydrate through a graded series of ethanol to water.
- Antigen Retrieval:
 - Perform heat-induced epitope retrieval (HIER) by immersing slides in a citrate buffer (pH 6.0) and heating in a pressure cooker or water bath at 95-100°C for 20 minutes.
 - Allow slides to cool to room temperature.
- Staining:
 - Wash sections with PBS.
 - Block endogenous peroxidase activity with a 3% hydrogen peroxide solution for 10 minutes.

- Block non-specific binding with a protein block solution (e.g., containing 5% normal goat serum) for 30 minutes.
- Incubate sections with the primary p-CSF-1R antibody overnight at 4°C in a humidified chamber.
- Wash with PBS and incubate with a biotinylated secondary antibody followed by a streptavidin-HRP complex.
- Develop the signal using a DAB substrate kit, monitoring for color development.
- Counterstain with hematoxylin, dehydrate, and mount with a coverslip.

Conclusion

The validation of phospho-specific antibodies is paramount for generating reliable data. When selecting a p-CSF-1R antibody, researchers must consider the specific phospho-site of interest, the intended application, and the species being studied. The data and protocols presented here serve as a guide to compare alternatives and establish a rigorous validation workflow in the laboratory. It is strongly recommended to perform in-house validation using appropriate positive and negative controls, such as ligand-stimulated and unstimulated cells, to ensure antibody specificity and performance under specific experimental conditions.

- [To cite this document: BenchChem. \[Comparative Guide to Phospho-CSF-1R Antibody Validation and Cross-Reactivity\]. BenchChem, \[2026\]. \[Online PDF\]. Available at: \[https://www.benchchem.com/product/b12421085/docs#comparative-guide-to-phospho-csf-1r-antibody-validation-and-cross-reactivity\]](https://www.benchchem.com/product/b12421085/docs#comparative-guide-to-phospho-csf-1r-antibody-validation-and-cross-reactivity)

Disclaimer & Data Validity:

The information provided in this document is for Research Use Only (RUO) and is strictly not intended for diagnostic or therapeutic procedures. While BenchChem strives to provide accurate protocols, we make no warranties, express or implied, regarding the fitness of this product for every specific experimental setup.

Technical Support: The protocols provided are for reference purposes. Unsure if this reagent suits your experiment?

Need Industrial/Bulk Grade? [Request Custom Synthesis Quote](#)

BenchChem

Our mission is to be the trusted global source of essential and advanced chemicals, empowering scientists and researchers to drive progress in science and industry.

Contact

Address: 3281 E Guasti Rd
Ontario, CA 91761, United States
Phone: (601) 213-4426
Email: info@benchchem.com

[Contact our Ph.D. Support Team for a compatibility check](#)