

CSF-1R Signaling in Neurodegenerative Disorders: A Technical Guide

Author: BenchChem Technical Support Team. **Date:** April 2026

Compound of Interest

Compound Name: GW2580-d6

Cat. No.: B12421085

[Get Quote](#)

For Researchers, Scientists, and Drug Development Professionals

Introduction

The Colony-Stimulating Factor 1 Receptor (CSF-1R) is a pivotal cell surface receptor tyrosine kinase that governs the survival, proliferation, differentiation, and function of microglia, the resident immune cells of the central nervous system (CNS). Dysregulation of CSF-1R signaling has emerged as a critical factor in the pathogenesis of several neurodegenerative disorders, including Alzheimer's disease, Parkinson's disease, and Amyotrophic Lateral Sclerosis. This technical guide provides an in-depth overview of CSF-1R signaling, its role in these diseases, and key experimental protocols for its investigation.

Core Signaling Pathway

Activation of CSF-1R by its ligands, Colony-Stimulating Factor 1 (CSF-1) and Interleukin-34 (IL-34), triggers receptor dimerization and autophosphorylation of specific tyrosine residues within its intracellular domain.[1] This initiates a cascade of downstream signaling events, primarily through the Phosphoinositide 3-kinase (PI3K)/AKT, Jun N-terminal kinase (JNK), and Extracellular signal-regulated kinase (ERK) pathways, which are crucial for microglial function and survival.[2]

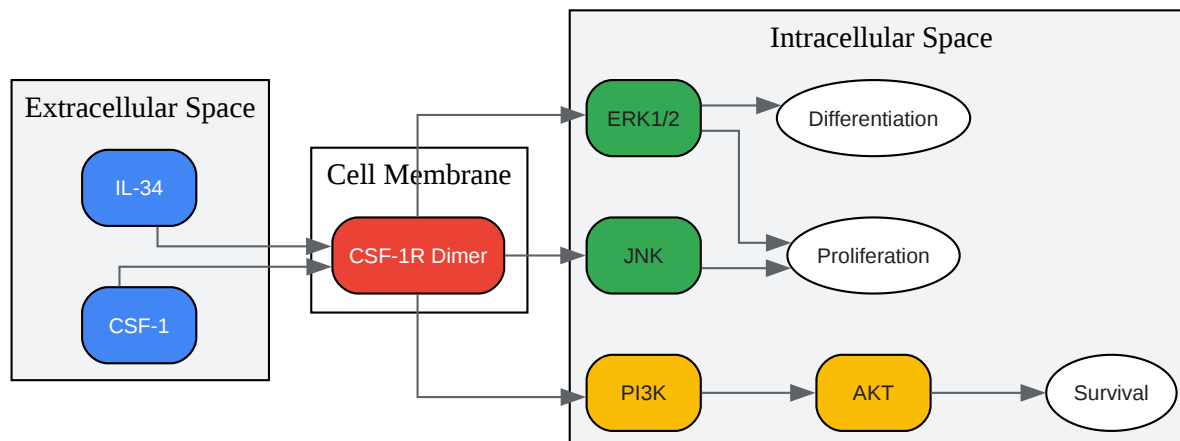

[Click to download full resolution via product page](#)

Caption: CSF-1R signaling cascade in microglia.

Role in Neurodegenerative Disorders

Alzheimer's Disease (AD)

In the context of Alzheimer's disease, CSF-1R signaling is implicated in the proliferation and activation of microglia surrounding amyloid-beta ($A\beta$) plaques.[3] Upregulation of both CSF-1R and its ligand CSF-1 has been observed in the brains of AD patients and in mouse models of the disease.[4][5] Pharmacological inhibition of CSF-1R has been shown to reduce microglial proliferation, prevent synaptic loss, and improve cognitive function in preclinical models, without altering the $A\beta$ plaque burden.[6]

Parkinson's Disease (PD)

Evidence suggests the involvement of CSF-1R-mediated neuroinflammation in the pathogenesis of Parkinson's disease. Increased expression of CSF-1 and CSF-1R has been reported in the substantia nigra of PD patients.[7] In animal models of PD, inhibition of CSF-1R signaling has been demonstrated to attenuate the loss of dopaminergic neurons and reduce motor deficits.[2][8]

Amyotrophic Lateral Sclerosis (ALS)

In ALS, CSF-1R signaling is associated with microgliosis in the spinal cord. Increased expression of CSF-1R and its ligand CSF-1 correlates with disease progression in the SOD1G93A mouse model of ALS.[9] Treatment with CSF-1R inhibitors has been shown to reduce microglial proliferation, slow disease progression, and extend survival in these models.

Quantitative Data on CSF-1R and Ligand Expression

The following tables summarize quantitative findings on the expression of CSF-1R and its ligands in various neurodegenerative disorders.

Table 1: CSF-1R and Ligand mRNA Expression in Human Alzheimer's Disease Brain

Gene	Brain Region	Change in AD vs. Control	Fold Change	Reference
CSF1R	Temporal Cortex	Increased	~1.5	[4]
CSF1	Temporal Cortex	Increased	~2.0	[4]
IL34	Temporal Cortex	No significant change	-	[4]
CSF1R	Inferior Temporal Gyrus	Increased	-	[5]
CSF1	Inferior Temporal Gyrus	Increased	-	[5]
IL34	Inferior Temporal Gyrus	Decreased	-	[5]

Table 2: CSF-1R and Ligand mRNA Expression in Animal Models

Model	Disorder	Brain/Spinal Cord Region	Gene	Change vs. Wild Type	Fold Change	Reference
APP/PS1 Mouse	Alzheimer's Disease	Cortex	Csf1r	Increased	~1.8	[4]
APP/PS1 Mouse	Alzheimer's Disease	Cortex	Csf1	Increased	~2.5	[4]
SOD1G93 A Mouse	ALS	Lumbar Spinal Cord	Csf1	Increased (late stage)	~2.0	[10]

Experimental Protocols

CSF-1R Kinase Assay

This protocol is adapted from commercially available kits for measuring CSF-1R kinase activity.

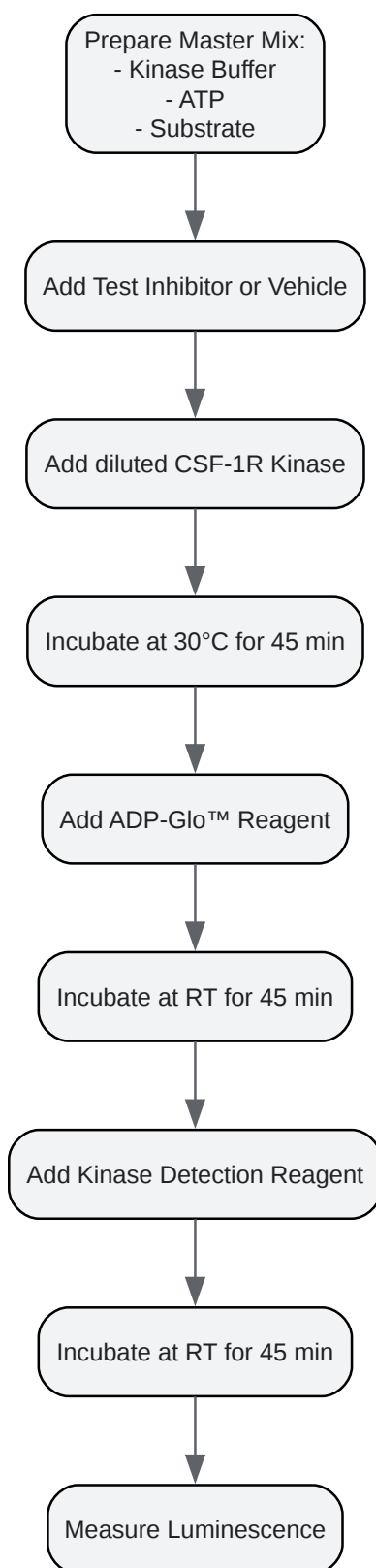

[Click to download full resolution via product page](#)

Caption: Workflow for a typical CSF-1R kinase assay.

Materials:

- CSF-1R Kinase Assay Kit (e.g., BPS Bioscience, Cat# 79110)
- Microplate reader capable of measuring luminescence
- 30°C incubator

Procedure:

- Prepare 1x Kinase Assay Buffer: Dilute the 5x Kinase Assay Buffer with water.
- Prepare Master Mix: Combine 1x Kinase Assay Buffer, ATP, and the protein kinase substrate (e.g., Poly(Glu,Tyr) 4:1).
- Add Test Inhibitor: Add the test inhibitor or vehicle (e.g., DMSO) to the appropriate wells.
- Initiate Reaction: Add the diluted CSF-1R kinase to each well.
- Incubate: Incubate the plate at 30°C for 45 minutes.
- Stop Reaction and Detect ADP: Add ADP-Glo™ Reagent and incubate at room temperature for 45 minutes.
- Develop Luminescent Signal: Add Kinase Detection Reagent and incubate at room temperature for 30-45 minutes.
- Measure Luminescence: Read the plate on a microplate reader.

Western Blotting for CSF-1R in Microglia

This protocol provides a general guideline for detecting CSF-1R in microglial cell lysates.

Materials:

- Primary antibody: Rabbit anti-CSF-1R (e.g., Cell Signaling Technology, #3152)
- Secondary antibody: HRP-linked anti-rabbit IgG

- RIPA buffer with protease and phosphatase inhibitors
- BCA Protein Assay Kit
- SDS-PAGE gels and transfer system
- ECL Western Blotting Substrate

Procedure:

- Cell Lysis: Lyse microglial cells in ice-cold RIPA buffer.
- Protein Quantification: Determine the protein concentration of the lysates using a BCA assay.
- SDS-PAGE: Separate 20-30 µg of protein per lane on an SDS-PAGE gel.
- Protein Transfer: Transfer the separated proteins to a PVDF membrane.
- Blocking: Block the membrane with 5% non-fat dry milk or BSA in TBST for 1 hour at room temperature.
- Primary Antibody Incubation: Incubate the membrane with the primary anti-CSF-1R antibody (e.g., 1:1000 dilution) overnight at 4°C.[11]
- Washing: Wash the membrane three times with TBST for 5-10 minutes each.
- Secondary Antibody Incubation: Incubate the membrane with the HRP-linked secondary antibody for 1 hour at room temperature.
- Washing: Repeat the washing step.
- Detection: Add ECL substrate and visualize the protein bands using a chemiluminescence imaging system.

Immunohistochemistry for CSF-1R in Frozen Brain Sections

This protocol is for the fluorescent detection of CSF-1R in cryosections of mouse brain tissue.

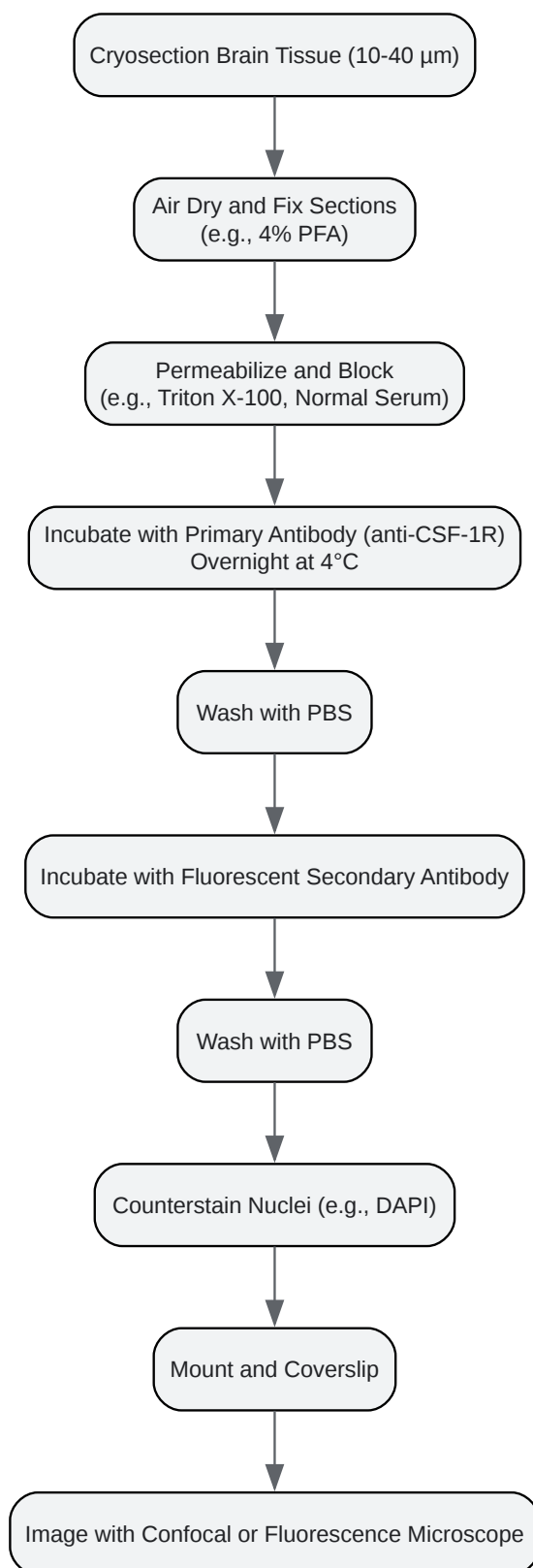

[Click to download full resolution via product page](#)

Caption: Immunohistochemistry workflow for CSF-1R.

Materials:

- Primary antibody: Rabbit anti-CSF-1R
- Secondary antibody: Fluorescently-labeled anti-rabbit IgG
- 4% Paraformaldehyde (PFA) in PBS
- Blocking solution: 5-10% normal serum (from the host species of the secondary antibody) in PBST (PBS with 0.1-0.3% Triton X-100)
- DAPI for nuclear counterstaining
- Mounting medium

Procedure:

- Tissue Preparation: Perfuse the mouse with PBS followed by 4% PFA. Post-fix the brain in 4% PFA overnight, then cryoprotect in 30% sucrose. Section the frozen brain at 10-40 μm on a cryostat.[\[10\]](#)
- Slide Preparation: Mount sections onto charged slides and air dry.
- Fixation and Permeabilization: Rehydrate sections in PBS. If not already fixed, fix with cold acetone or methanol, or 4% PFA. Permeabilize with PBST.
- Blocking: Block non-specific binding by incubating sections in blocking solution for 1 hour at room temperature.[\[12\]](#)
- Primary Antibody Incubation: Incubate with the primary anti-CSF-1R antibody diluted in blocking solution overnight at 4°C in a humidified chamber.
- Washing: Wash the slides three times with PBS for 5-10 minutes each.
- Secondary Antibody Incubation: Incubate with the fluorescently-labeled secondary antibody for 1-2 hours at room temperature, protected from light.
- Washing: Repeat the washing step.

- Counterstaining: Incubate with DAPI for 5-10 minutes to stain cell nuclei.
- Mounting: Wash briefly in PBS and mount with an anti-fade mounting medium.
- Imaging: Visualize the staining using a fluorescence or confocal microscope.

Conclusion

The CSF-1R signaling pathway represents a critical nexus in the neuroinflammatory processes that contribute to the progression of neurodegenerative diseases. Targeting this pathway, primarily through the inhibition of CSF-1R kinase activity, holds significant therapeutic promise. The experimental protocols and data presented in this guide provide a framework for researchers to further investigate the intricate role of CSF-1R in neurodegeneration and to advance the development of novel therapeutic strategies.

Need Custom Synthesis?

BenchChem offers custom synthesis for rare earth carbides and specific isotopic labeling.

Email: info@benchchem.com or [Request Quote Online](#).

References

- [1. Insights Into the Role of CSF1R in the Central Nervous System and Neurological Disorders - PMC \[pmc.ncbi.nlm.nih.gov\]](#)
- [2. Frontiers | Insights Into the Role of CSF1R in the Central Nervous System and Neurological Disorders \[frontiersin.org\]](#)
- [3. researchgate.net \[researchgate.net\]](#)
- [4. Pharmacological targeting of CSF1R inhibits microglial proliferation and prevents the progression of Alzheimer's-like pathology - PMC \[pmc.ncbi.nlm.nih.gov\]](#)
- [5. Frontiers | Studies on Colony Stimulating Factor Receptor-1 and Ligands Colony Stimulating Factor-1 and Interleukin-34 in Alzheimer's Disease Brains and Human Microglia \[frontiersin.org\]](#)
- [6. academic.oup.com \[academic.oup.com\]](#)
- [7. Upregulation of APAF1 and CSF1R in Peripheral Blood Mononuclear Cells of Parkinson's Disease - PMC \[pmc.ncbi.nlm.nih.gov\]](#)

- [8. researchgate.net \[researchgate.net\]](#)
- [9. INTERPLAY BETWEEN IMMUNITY AND AMYOTROPHIC LATERAL SCLEROSIS: CLINICAL IMPACT - PMC \[pmc.ncbi.nlm.nih.gov\]](#)
- [10. Immunofluorescence protocol for frozen sections \[sites.wustl.edu\]](#)
- [11. CSF-1R/M-CSF-R Antibody | Cell Signaling Technology \[cellsignal.com\]](#)
- [12. mskcc.org \[mskcc.org\]](#)
- To cite this document: BenchChem. [CSF-1R Signaling in Neurodegenerative Disorders: A Technical Guide]. BenchChem, [2026]. [Online PDF]. Available at: [\[https://www.benchchem.com/product/b12421085/docs#csf-1r-signaling-in-neurodegenerative-disorders-a-technical-guide\]](https://www.benchchem.com/product/b12421085/docs#csf-1r-signaling-in-neurodegenerative-disorders-a-technical-guide)

Disclaimer & Data Validity:

The information provided in this document is for Research Use Only (RUO) and is strictly not intended for diagnostic or therapeutic procedures. While BenchChem strives to provide accurate protocols, we make no warranties, express or implied, regarding the fitness of this product for every specific experimental setup.

Technical Support: The protocols provided are for reference purposes. Unsure if this reagent suits your experiment?

Need Industrial/Bulk Grade? [Request Custom Synthesis Quote](#)

BenchChem

Our mission is to be the trusted global source of essential and advanced chemicals, empowering scientists and researchers to drive progress in science and industry.

Contact

Address: 3281 E Guasti Rd

Ontario, CA 91761, United States

Phone: (601) 213-4426

Email: info@benchchem.com

Contact our Ph.D. Support Team for a compatibility check