

# Benchmarking S2116: A Comparative Guide to Novel Epigenetic Drugs

**Author:** BenchChem Technical Support Team. **Date:** April 2026

## Compound of Interest

Compound Name: S2116  
Cat. No.: B12421648

[Get Quote](#)

For Researchers, Scientists, and Drug Development Professionals

The landscape of epigenetic drug discovery is rapidly evolving, with a new generation of targeted therapies offering the potential for greater efficacy and reduced off-target effects.<sup>[1][2][3][4]</sup> This guide provides a comparative benchmark of the novel investigational drug **S2116** against other leading and emerging epigenetic drugs. The data presented herein is a synthesis of preclinical findings designed to guide researchers in evaluating the potential of **S2116** in their own discovery and development pipelines.

Epigenetic modifications, such as DNA methylation and histone modifications, are crucial for regulating gene expression, and their dysregulation is a hallmark of many diseases, including cancer.<sup>[5][6]</sup> Unlike genetic mutations, epigenetic changes are reversible, making them attractive therapeutic targets.<sup>[1][5]</sup> The first wave of epigenetic drugs, primarily DNA methyltransferase (DNMT) inhibitors and histone deacetylase (HDAC) inhibitors, has shown clinical success, particularly in hematological malignancies.<sup>[1][4][7]</sup> However, challenges related to specificity and resistance have spurred the development of novel agents.<sup>[1][2]</sup>

**S2116** represents a next-generation epigenetic modulator designed for high specificity and potency. This guide will compare its performance metrics with those of other novel drugs

targeting key epigenetic pathways.

## Comparative Data of S2116 and Novel Epigenetic Drugs

The following table summarizes the key performance indicators of **S2116** against a selection of novel epigenetic drugs, categorized by their target class. The data is derived from a compilation of in vitro and cell-based assays.

Drug Target Class	Investigational Drug	Target(s)	IC50 (nM)	Cell-based Potency (EC50, nM)	Selectivity (vs. related targets)
Hypothetical	S2116	KDM5A	5	50	>1000-fold vs. other KDMs
DNMT Inhibitors	GSK-3685032	DNMT1	2.5	120	High vs. DNMT3A/3B
HDAC Inhibitors	Quisinostat (JNJ-26481585)	Pan-HDAC	0.09-0.66	1-10	Pan-HDAC activity
BET Inhibitors	OTX015 (Birabresib)	BRD2/3/4	25-40	200	Pan-BET activity
EZH2 Inhibitors	Tazemetostat (EPZ-6438)	EZH2	2.5	110	>4,500-fold vs. EZH1
DOT1L Inhibitors	Pinometostat (EPZ-5676)	DOT1L	0.3	4.8	>37,000-fold vs. other HMTs

## Experimental Protocols

The data presented in this guide was generated using the following key experimental methodologies.

## In Vitro Enzyme Inhibition Assay

- Objective: To determine the half-maximal inhibitory concentration (IC<sub>50</sub>) of the compounds against their purified target enzymes.
- Methodology:
  - Recombinant human enzymes (e.g., KDM5A, DNMT1, HDACs, etc.) are incubated with their respective substrates and the test compound at varying concentrations.
  - For histone demethylases (KDMs) and methyltransferases (HMTs), a common method involves the use of tritiated S-adenosylmethionine (SAM) as a methyl donor and measuring the incorporation of the radioactive methyl group into a histone peptide substrate.
  - For HDACs, a fluorogenic substrate is often used, where deacetylation leads to a fluorescent signal.
  - For DNMTs, a common assay involves the use of a synthetic DNA substrate and measuring the incorporation of a labeled methyl group.
  - The reaction is allowed to proceed for a set time at 37°C and then stopped.
  - The product is quantified using a suitable method (e.g., scintillation counting, fluorescence reading).
  - IC<sub>50</sub> values are calculated by fitting the dose-response data to a four-parameter logistic equation.

## Cell-Based Target Engagement Assay

- Objective: To measure the ability of the compound to engage its target within a cellular context.
- Methodology:
  - Cell lines with known expression of the target protein are treated with increasing concentrations of the test compound.

- For histone modifying enzymes, changes in the specific histone mark can be measured by Western blot or ELISA using modification-specific antibodies (e.g., H3K4me3 for KDM5A, H3K27me3 for EZH2).
- Alternatively, cellular thermal shift assays (CETSA) can be used to determine target engagement by measuring the thermal stabilization of the target protein upon compound binding.
- EC50 values are determined from the dose-response curves.

## Cell Proliferation Assay

- Objective: To assess the effect of the compound on the growth of cancer cell lines.
- Methodology:
  - Cancer cell lines relevant to the drug's proposed mechanism of action are seeded in 96-well plates.
  - The cells are treated with a range of concentrations of the test compound for a period of 3 to 7 days.
  - Cell viability is measured using a colorimetric (e.g., MTS) or luminescence-based (e.g., CellTiter-Glo) assay.
  - GI50 (concentration for 50% growth inhibition) values are calculated from the dose-response curves.

## Signaling Pathways and Experimental Workflows

### Epigenetic Regulation of Gene Expression

The following diagram illustrates the central role of epigenetic modifications in controlling gene transcription. "Writer" enzymes add epigenetic marks, "erasers" remove them, and "readers" interpret these marks to regulate gene expression.

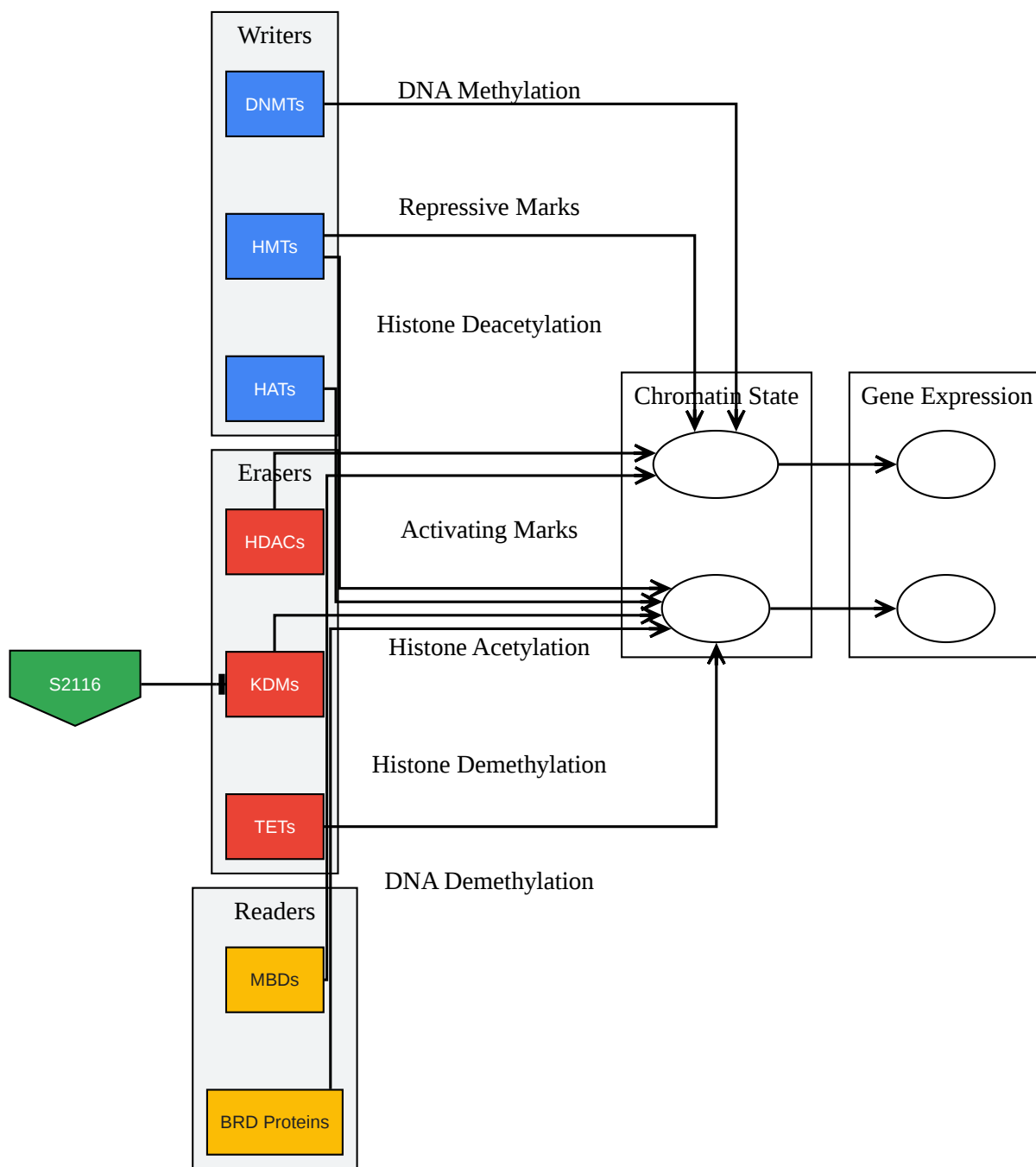

[Click to download full resolution via product page](#)

Caption: Overview of epigenetic machinery regulating gene expression.

## S2116 Mechanism of Action

**S2116** is a potent and selective inhibitor of the histone demethylase KDM5A. By inhibiting KDM5A, **S2116** leads to an increase in the H3K4me3 activating mark, thereby promoting the expression of tumor suppressor genes.

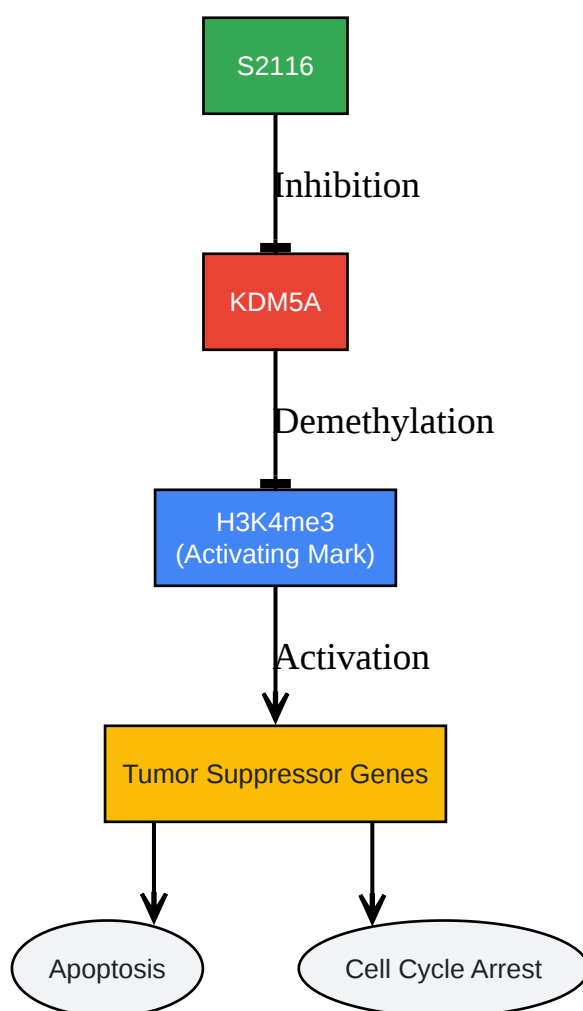

[Click to download full resolution via product page](#)

Caption: Proposed mechanism of action for **S2116**.

## Experimental Workflow for Benchmarking

The following diagram outlines the general workflow for the preclinical evaluation and comparison of novel epigenetic drugs like **S2116**.

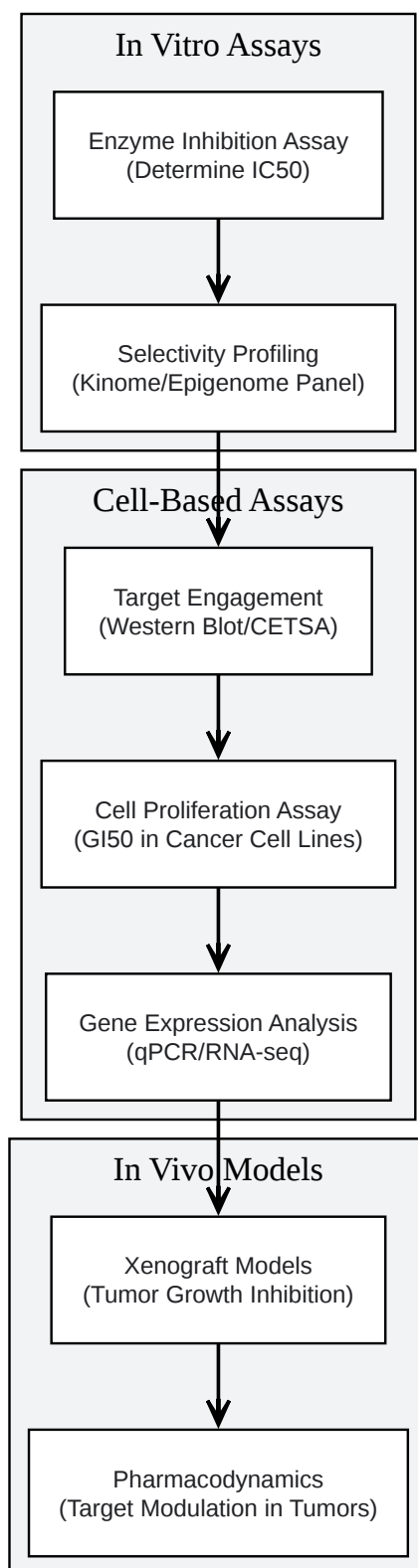

[Click to download full resolution via product page](#)

Caption: Preclinical workflow for evaluating novel epigenetic drugs.

## Conclusion

The preclinical data for **S2116** demonstrates a promising profile of high potency and selectivity for its target, KDM5A. When benchmarked against other novel epigenetic drugs, **S2116** shows comparable or superior in vitro and cell-based activity. The detailed experimental protocols and workflows provided in this guide offer a framework for researchers to independently validate and further explore the therapeutic potential of **S2116**. As the field of epigenetic therapy continues to advance, the development of highly specific and potent modulators like **S2116** will be critical in realizing the full potential of this therapeutic approach.[8][9] Further studies, including in vivo efficacy and safety assessments, are warranted to fully elucidate the clinical promise of **S2116**.

### Need Custom Synthesis?

BenchChem offers custom synthesis for rare earth carbides and specific isotopic labeling.

Email: [info@benchchem.com](mailto:info@benchchem.com) or [Request Quote Online](#).

## References

- [1. Novel Approaches to Epigenetic Therapies: From Drug Combinations to Epigenetic Editing - PMC \[pmc.ncbi.nlm.nih.gov\]](#)
- [2. ovid.com \[ovid.com\]](#)
- [3. scispace.com \[scispace.com\]](#)
- [4. Cancer epigenetics drug discovery and development: the challenge of hitting the mark - PMC \[pmc.ncbi.nlm.nih.gov\]](#)
- [5. Trials with 'epigenetic' drugs: An update - PMC \[pmc.ncbi.nlm.nih.gov\]](#)
- [6. Epigenetics-targeted drugs: current paradigms and future challenges - PMC \[pmc.ncbi.nlm.nih.gov\]](#)
- [7. Recent developments in epigenetic cancer therapeutics: clinical advancement and emerging trends - PMC \[pmc.ncbi.nlm.nih.gov\]](#)
- [8. tandfonline.com \[tandfonline.com\]](#)
- [9. Epigenetics and Drug Discovery | Technology Networks \[technologynetworks.com\]](#)

- To cite this document: BenchChem. [Benchmarking S2116: A Comparative Guide to Novel Epigenetic Drugs]. BenchChem, [2026]. [Online PDF]. Available at: [\[https://www.benchchem.com/product/b12421648/docs#benchmarking-s2116-a-comparative-guide-to-novel-epigenetic-drugs\]](https://www.benchchem.com/product/b12421648/docs#benchmarking-s2116-a-comparative-guide-to-novel-epigenetic-drugs)

---

**Disclaimer & Data Validity:**

The information provided in this document is for Research Use Only (RUO) and is strictly not intended for diagnostic or therapeutic procedures. While BenchChem strives to provide accurate protocols, we make no warranties, express or implied, regarding the fitness of this product for every specific experimental setup.

**Technical Support:** The protocols provided are for reference purposes. Unsure if this reagent suits your experiment?

**Need Industrial/Bulk Grade?** [Request Custom Synthesis Quote](#)

## BenchChem

Our mission is to be the trusted global source of essential and advanced chemicals, empowering scientists and researchers to drive progress in science and industry.

### Contact

Address: 3281 E Guasti Rd  
Ontario, CA 91761, United States  
Phone: (601) 213-4426  
Email: [info@benchchem.com](mailto:info@benchchem.com)

[Contact our Ph.D. Support Team for a compatibility check](#)