

BACE1-IN-4 Technical Support Center: Troubleshooting Aqueous Solubility

Author: BenchChem Technical Support Team. **Date:** April 2026

Compound of Interest

Compound Name: *Bace1-IN-4*

Cat. No.: *B12421855*

[Get Quote](#)

Welcome to the technical support center for BACE1-IN-A4. This guide provides researchers, scientists, and drug development professionals with detailed information to address common solubility challenges encountered when working with **BACE1-IN-4** in aqueous solutions. The following sections offer troubleshooting advice, frequently asked questions (FAQs), experimental protocols, and relevant pathway information to facilitate your research.

Frequently Asked Questions (FAQs) & Troubleshooting Guide

This section addresses common questions and problems related to the solubility of **BACE1-IN-4** in aqueous solutions.

Q1: What is the known solubility of **BACE1-IN-4**?

A1: **BACE1-IN-4** is readily soluble in dimethyl sulfoxide (DMSO) at a concentration of 10 mM. [1] However, specific quantitative data regarding its solubility in aqueous buffers such as Phosphate-Buffered Saline (PBS) or cell culture media is not widely published. Like many small molecule inhibitors, **BACE1-IN-4** is expected to have limited solubility in purely aqueous solutions due to its hydrophobic nature.

Q2: I am observing precipitation when I dilute my **BACE1-IN-4** DMSO stock solution into an aqueous buffer. What should I do?

A2: This is a common issue with hydrophobic compounds. Here are several troubleshooting steps you can take:

- **Decrease the Final Concentration:** The most straightforward approach is to lower the final concentration of **BACE1-IN-4** in your aqueous solution.
- **Increase the Percentage of Co-solvent:** If your experimental system can tolerate it, increasing the final percentage of DMSO may help keep the compound in solution. However, be mindful that high concentrations of DMSO can be toxic to cells. It is recommended to keep the final DMSO concentration below 0.5% for most cell-based assays.
- **Use a Different Co-solvent:** While DMSO is common, other organic solvents like ethanol can be used. A 1:1 solution of ethanol:PBS (pH 7.2) has been used for other sparingly soluble BACE1 inhibitors.[2]
- **Sonication:** After diluting the DMSO stock into the aqueous buffer, brief sonication can help to disperse the compound and break up any initial aggregates that may have formed.
- **Gentle Warming:** Gently warming the solution to 37°C may temporarily increase solubility. However, be cautious as prolonged heating can degrade the compound. Always check the compound's stability at elevated temperatures.
- **Use of Pluronic F-68 or other surfactants:** A small amount of a non-ionic surfactant like Pluronic F-68 can aid in solubilizing hydrophobic compounds in aqueous media.

Q3: Can I prepare a stock solution of **BACE1-IN-4** directly in an aqueous buffer?

A3: It is generally not recommended to prepare a primary stock solution of **BACE1-IN-4** in an aqueous buffer due to its low solubility. The recommended practice is to first prepare a high-concentration stock solution in an organic solvent like DMSO and then dilute this stock into the desired aqueous buffer for your working solution.

Q4: How should I store my **BACE1-IN-4** solutions?

A4:

- **DMSO Stock Solution:** Aliquot your DMSO stock solution into small, single-use volumes and store them at -20°C or -80°C to minimize freeze-thaw cycles. Stock solutions in DMSO are generally stable for several months at -20°C.
- **Aqueous Working Solutions:** It is highly recommended to prepare aqueous working solutions fresh for each experiment. We do not recommend storing aqueous solutions for more than one day.[2] If precipitation is observed after storage, the solution should be discarded.

Quantitative Data Presentation

As specific public data on the aqueous solubility of **BACE1-IN-4** is limited, the following table provides a summary of its known solubility in an organic solvent. Researchers should empirically determine the maximum soluble concentration in their specific aqueous buffer system.

Solvent	Concentration	Notes
DMSO	10 mM	Readily soluble.[1]
Aqueous Buffers	Not Reported	Expected to have low solubility.

Experimental Protocols

Protocol for Preparing a Working Solution of **BACE1-IN-4** in Aqueous Buffer

This protocol provides a general method for preparing a working solution of **BACE1-IN-4** from a DMSO stock. The final concentration and buffer composition should be optimized for your specific experimental needs.

Materials:

- **BACE1-IN-4** powder
- Dimethyl sulfoxide (DMSO), anhydrous

- Desired aqueous buffer (e.g., PBS, pH 7.4; Sodium Acetate buffer, pH 4.5)
- Sterile microcentrifuge tubes
- Vortex mixer
- Sonicator (optional)

Procedure:

- Prepare a 10 mM Stock Solution in DMSO:
 - Calculate the required mass of **BACE1-IN-4** to prepare your desired volume of a 10 mM stock solution (Molecular Weight: 511.57 g/mol).
 - Carefully weigh the **BACE1-IN-4** powder and dissolve it in the appropriate volume of anhydrous DMSO.
 - Vortex thoroughly until the compound is completely dissolved.
- Prepare the Aqueous Working Solution (Serial Dilution):
 - It is recommended to perform a serial dilution to minimize precipitation.
 - For a 1 μM final concentration in a 1 mL volume with a final DMSO concentration of 0.1%:
 - Pipette 99 μL of your aqueous buffer into a sterile microcentrifuge tube.
 - Add 1 μL of the 10 mM **BACE1-IN-4** DMSO stock solution to the tube.
 - Immediately vortex the solution vigorously for at least 30 seconds to ensure rapid mixing. This will create an intermediate dilution.
 - Take 10 μL of this intermediate dilution and add it to 990 μL of your final aqueous buffer.
 - Vortex thoroughly.
- Final Check and Use:

- Visually inspect the final working solution for any signs of precipitation. If the solution appears cloudy or contains visible particles, it should not be used. Consider further dilution or other troubleshooting steps.
- Use the freshly prepared working solution in your experiment immediately.

Mandatory Visualizations

BACE1 Signaling Pathway in Amyloid Precursor Protein (APP) Processing

The primary and most well-known function of BACE1 is its role in the amyloidogenic processing of the Amyloid Precursor Protein (APP), which leads to the generation of amyloid-beta ($A\beta$) peptides, a hallmark of Alzheimer's disease.[3][4][5] BACE1 initiates this pathway by cleaving APP at the β -secretase site.

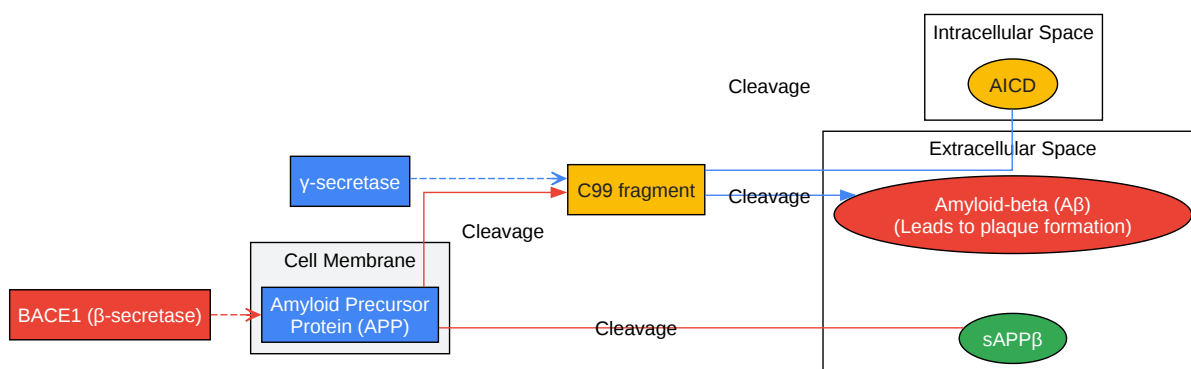

[Click to download full resolution via product page](#)

Caption: Amyloidogenic processing of APP by BACE1 and γ -secretase.

Experimental Workflow for Troubleshooting BACE1-IN-4 Solubility

This workflow provides a logical sequence of steps for researchers to follow when encountering solubility issues with **BACE1-IN-4** in their experiments.

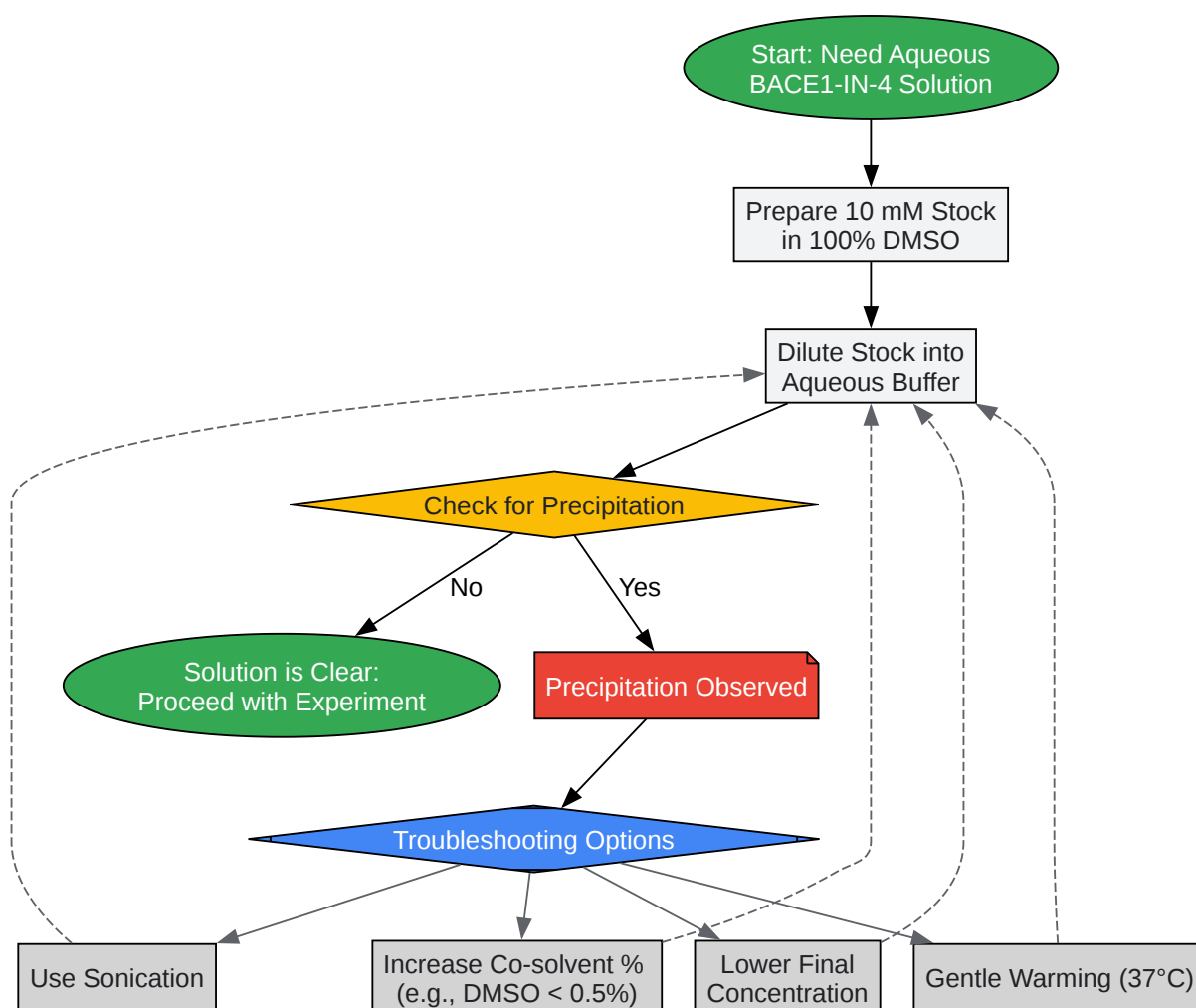

[Click to download full resolution via product page](#)

Caption: A logical workflow for addressing **BACE1-IN-4** solubility issues.

Need Custom Synthesis?

BenchChem offers custom synthesis for rare earth carbides and specific isotopic labeling.

Email: info@benchchem.com or [Request Quote Online](#).

References

- [1. BACE1-IN-4 - Immunomart \[immunomart.com\]](#)
- [2. cdn.caymanchem.com \[cdn.caymanchem.com\]](#)
- [3. researchgate.net \[researchgate.net\]](#)
- [4. mdpi.com \[mdpi.com\]](#)
- [5. BACE1: More than just a \$\beta\$ -secretase - PMC \[pmc.ncbi.nlm.nih.gov\]](#)
- To cite this document: BenchChem. [BACE1-IN-4 Technical Support Center: Troubleshooting Aqueous Solubility]. BenchChem, [2026]. [Online PDF]. Available at: [\[https://www.benchchem.com/product/b12421855/docs#bace1-in-4-technical-support-center-troubleshooting-aqueous-solubility\]](https://www.benchchem.com/product/b12421855/docs#bace1-in-4-technical-support-center-troubleshooting-aqueous-solubility)

Disclaimer & Data Validity:

The information provided in this document is for Research Use Only (RUO) and is strictly not intended for diagnostic or therapeutic procedures. While BenchChem strives to provide accurate protocols, we make no warranties, express or implied, regarding the fitness of this product for every specific experimental setup.

Technical Support: The protocols provided are for reference purposes. Unsure if this reagent suits your experiment?

Need Industrial/Bulk Grade? [Request Custom Synthesis Quote](#)

BenchChem

Our mission is to be the trusted global source of essential and advanced chemicals, empowering scientists and researchers to drive progress in science and industry.

Contact

Address: 3281 E Guasti Rd

Ontario, CA 91761, United States

Phone: (601) 213-4426

Email: info@benchchem.com

[Contact our Ph.D. Support Team for a compatibility check](#)