

Application Notes and Protocols for WW45 (SAV1) in Rodent Experiments

Author: BenchChem Technical Support Team. **Date:** April 2026

Compound of Interest

Compound Name: WW437
Cat. No.: B12421910

[Get Quote](#)

Disclaimer: The compound "**WW437**" was not found in publicly available scientific literature. Based on the search results, it is highly probable that this is a typographical error for WW45, also known as Salvador Family WW Domain Containing Protein 1 (SAV1). All following information pertains to WW45 (SAV1).

Introduction: WW45, or SAV1, is a critical scaffold protein and tumor suppressor that is a core component of the Hippo signaling pathway.[1][2] It plays a fundamental role in controlling organ size, cell proliferation, and apoptosis.[2] Aberrant expression or function of WW45 is linked to tumorigenesis in various cancers.[1][2] WW45 also interacts with the Hedgehog signaling pathway by binding to the transcription factor Gli1, thereby inhibiting its activity.[1][3][4]

Rodent-based research on WW45 does not typically involve the administration of a WW45 compound. Instead, studies utilize genetically engineered mouse models (GEMMs), such as knockout and transgenic mice, or employ viral vectors to modulate WW45 expression in vivo. These approaches are essential for understanding the protein's function in development and disease.

Signaling Pathways Involving WW45

WW45 is a key regulator in two major signaling pathways crucial to cell fate and cancer biology.

1. The Hippo Signaling Pathway: WW45 acts as a scaffold protein that binds to the kinase MST1/2 (mammalian sterile 20-like kinase 1/2), promoting its activation.[2][5] Activated MST1/2, in complex with WW45, phosphorylates and activates the LATS1/2 kinase. LATS1/2 then phosphorylates the transcriptional co-activator YAP (Yes-associated protein), leading to its cytoplasmic retention and degradation. When this pathway is inactive, YAP translocates to the nucleus, promoting the expression of genes that drive cell proliferation and inhibit apoptosis.

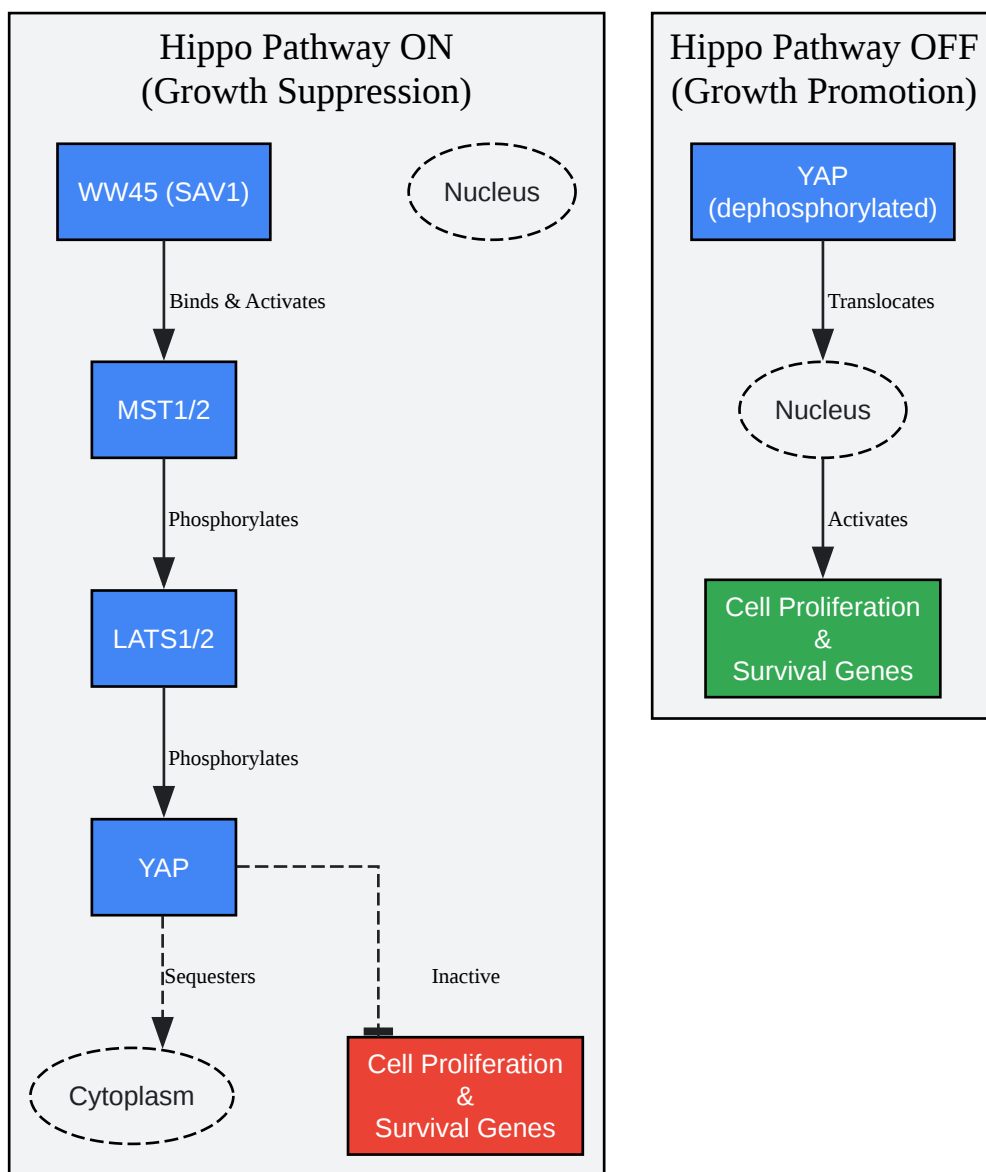

[Click to download full resolution via product page](#)

Diagram 1: The Hippo Signaling Pathway. (Max Width: 760px)

2. The Hedgehog Signaling Pathway Interaction: WW45 can directly interact with Gli1, a key transcription factor in the Hedgehog pathway.[1][3] This physical interaction anchors Gli1 in the cytoplasm, preventing its translocation into the nucleus and subsequent activation of target genes that are involved in cell proliferation and tumorigenesis.[1] This represents a negative regulatory role for WW45 on Hedgehog signaling.[3][4]

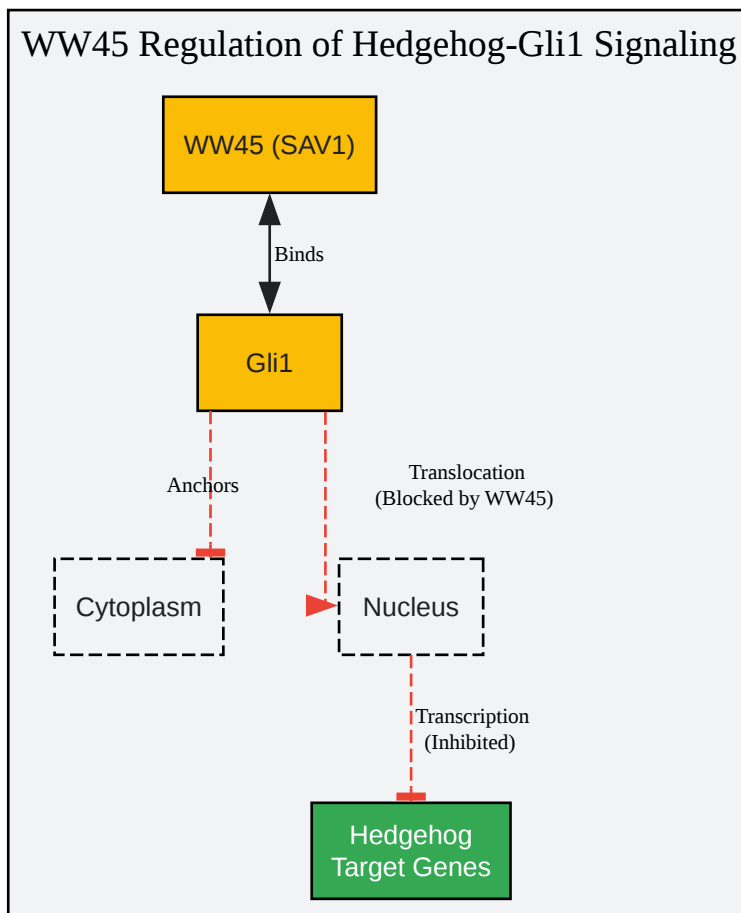

[Click to download full resolution via product page](#)

Diagram 2: WW45 Interaction with Hedgehog Pathway. (Max Width: 760px)

Application Notes: WW45 Modulation in Rodent Models

As direct administration of a WW45 compound is not a current research method, these notes focus on genetic modulation techniques.

Genetically Engineered Mouse Models (GEMMs)

GEMMs are the primary tools for studying the in vivo function of WW45. This involves either removing the gene (knockout) or forcing its expression (transgenic).

Model Type	Genotype	Key Phenotype	Reference
Systemic Knockout	WW45 ^{-/-} (Homozygous)	Embryonic lethal; display growth retardation and defective placental development.	[6][7]
WW45 ^{+/-} (Heterozygous)	Viable and fertile but prone to developing tumors (e.g., liver cancer) at a high incidence with age.	[1][6]	
Conditional Knockout	WW45cKO (Cardiac-specific)	At baseline, no significant effect on heart size. Under pressure overload, mice show severe cardiac dysfunction.	[8]
Transgenic	Overexpression (e.g., in liver)	Transgenic mice overexpressing YAP S127A (a constitutively active form of YAP, mimicking WW45 loss) develop enlarged livers.	[6]

Viral Vector-Mediated Gene Expression

For tissue-specific or time-controlled expression, viral vectors can be used to deliver the WW45 gene in vivo. This method provides an analogue to "dosage and administration."

Vector System	"Dosage" (Titer)	Administration Route	Mouse Model	Outcome	Reference
Retrovirus	2 x 10 ⁶ PFU/mouse	Nasal Inhalation	LKB-Ras (de novo NSCLC model)	Overexpression of WW45 inhibited tumorigenesis and improved survival.	[3]

Experimental Protocols

Protocol 1: In Vivo Overexpression of WW45 in a Lung Cancer Mouse Model

This protocol is adapted from studies using a Kras/LKB1 mutant (LKB-Ras) mouse model of non-small cell lung cancer (NSCLC).[3]

Objective: To achieve overexpression of WW45 in lung tissue to assess its effect on tumor development.

Materials:

- LKB-Ras mice (KrasG12D/Lkb1L/L)
- Retroviral vector encoding human or mouse WW45 (e.g., pBabe-WW45)
- Retroviral vector encoding Cre recombinase (to initiate tumorigenesis)
- Virus packaging and production system
- Anesthesia (e.g., isoflurane)
- Pipettor and sterile tips

Procedure:

- Virus Preparation: Produce high-titer retrovirus for both WW45 and Cre recombinase. Determine the viral titer (Plaque Forming Units/mL).
- Animal Preparation: Anesthetize LKB-Ras mice according to approved institutional animal care protocols.
- Administration:
 - Administer a viral dose of 2×10^6 PFU per mouse for each virus (WW45 and Cre).[3]
 - The administration is performed via nasal inhalation, which targets the lung epithelium.
 - Hold the mouse in a supine position and carefully pipette the viral solution into the nostrils.
- Monitoring:
 - Monitor the mice for recovery from anesthesia.
 - Observe mice regularly for signs of distress, weight loss, or labored breathing.
 - Follow tumor progression using imaging techniques (e.g., micro-CT) or at defined endpoints.
- Endpoint Analysis:
 - At the study endpoint (e.g., 12 weeks post-administration), euthanize the mice.[3]
 - Harvest lung tissues for histopathological analysis (H&E staining), immunohistochemistry (to confirm WW45 and Gli1 expression), and molecular analysis (Western blot, qPCR).

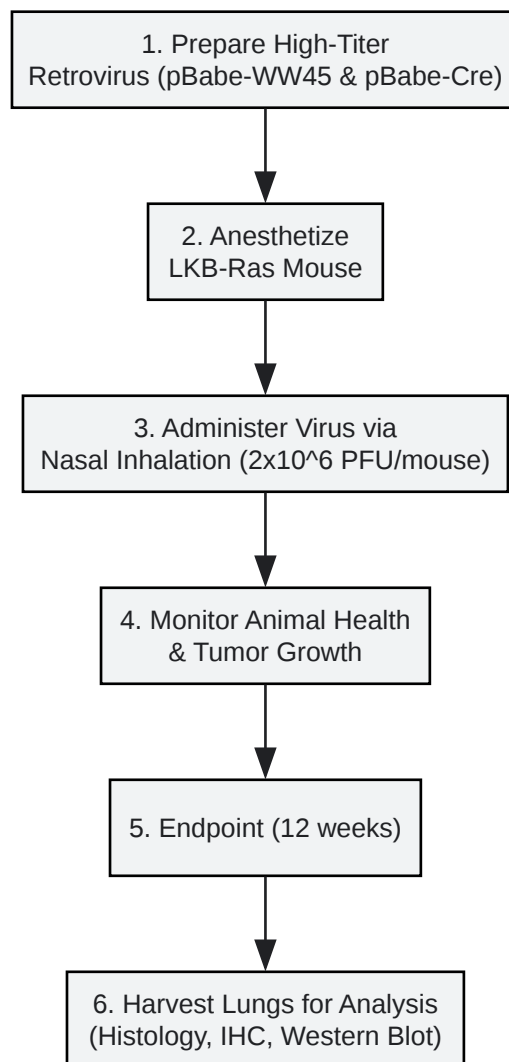

[Click to download full resolution via product page](#)

Diagram 3: Workflow for In Vivo WW45 Overexpression. (Max Width: 760px)

Protocol 2: Phenotypic Analysis of WW45-Modified Rodents

Objective: To characterize the physiological and pathological consequences of WW45 modulation.

1. Tumor Monitoring and Measurement:

- For tumor-prone models (e.g., WW45 \pm mice or virally-induced cancer models), monitor animals at least weekly for tumor development.

- Measure tumor size with calipers (for subcutaneous tumors) or via non-invasive imaging (micro-CT, MRI, or bioluminescence).

- Record body weight and clinical signs of illness.

2. Histological and Immunohistochemical Analysis:

- At necropsy, fix tissues (e.g., liver, lung, heart) in 4% paraformaldehyde or formalin.
- Embed tissues in paraffin and section for Hematoxylin and Eosin (H&E) staining to assess tissue morphology and tumor pathology.
- Perform immunohistochemistry (IHC) using antibodies against:
 - WW45/SAV1: To confirm knockout or overexpression.
 - Ki67: To assess cell proliferation.
 - Cleaved Caspase-3: To assess apoptosis.
 - YAP and Phospho-YAP: To determine Hippo pathway activity.
 - Gli1: To assess Hedgehog pathway activity.

3. Molecular Analysis:

- Western Blot: Prepare protein lysates from fresh-frozen tissues to quantify levels of WW45, total YAP, p-YAP, Gli1, and other pathway components.
- Quantitative PCR (qPCR): Isolate RNA from tissues to measure the mRNA levels of WW45 and downstream target genes of the Hippo and Hedgehog pathways.
- Genotyping: For GEMMs, isolate genomic DNA from tail clips or ear punches. Use PCR with specific primers to distinguish between wild-type, heterozygous, and homozygous knockout alleles.[\[6\]](#)

Need Custom Synthesis?

BenchChem offers custom synthesis for rare earth carbides and specific isotopic labeling.

Email: info@benchchem.com or [Request Quote Online](#).

References

- 1. WW45 inhibits breast cancer cell proliferation by the Hedgehog signaling pathway - PMC [[pmc.ncbi.nlm.nih.gov](https://pubmed.ncbi.nlm.nih.gov/)]
- 2. The tumor suppressor role of salvador family WW domain-containing protein 1 (SAV1): one of the key pieces of the tumor puzzle - PMC [[pmc.ncbi.nlm.nih.gov](https://pubmed.ncbi.nlm.nih.gov/)]
- 3. WW45, a Gli1 binding protein, negatively regulated Hedgehog signaling in lung cancer - PMC [[pmc.ncbi.nlm.nih.gov](https://pubmed.ncbi.nlm.nih.gov/)]
- 4. WW45, a Gli1 binding protein, negatively regulated Hedgehog signaling in lung cancer - PubMed [pubmed.ncbi.nlm.nih.gov]
- 5. The human WW45 protein enhances MST1-mediated apoptosis in vivo - PubMed [pubmed.ncbi.nlm.nih.gov]
- 6. A crucial role of WW45 in developing epithelial tissues in the mouse - PMC [[pmc.ncbi.nlm.nih.gov](https://pubmed.ncbi.nlm.nih.gov/)]
- 7. A crucial role of WW45 in developing epithelial tissues in the mouse | The EMBO Journal [[link.springer.com](https://www.embojournal.org/)]
- 8. [researchgate.net](https://www.researchgate.net/) [[researchgate.net](https://www.researchgate.net/)]
- To cite this document: BenchChem. [Application Notes and Protocols for WW45 (SAV1) in Rodent Experiments]. BenchChem, [2026]. [Online PDF]. Available at: [<https://www.benchchem.com/product/b12421910/docs#application-notes-and-protocols-for-ww45-sav1-in-rodent-experiments>]

Disclaimer & Data Validity:

The information provided in this document is for Research Use Only (RUO) and is strictly not intended for diagnostic or therapeutic procedures. While BenchChem strives to provide accurate protocols, we make no warranties, express or implied, regarding the fitness of this product for every specific experimental setup.

Technical Support: The protocols provided are for reference purposes. Unsure if this reagent suits your experiment?

Need Industrial/Bulk Grade? [Request Custom Synthesis Quote](#)

BenchChem

Our mission is to be the trusted global source of essential and advanced chemicals, empowering scientists and researchers to drive progress in science and industry.

Contact

Address: 3281 E Guasti Rd
Ontario, CA 91761, United States
Phone: (601) 213-4426
Email: info@benchchem.com

[Contact our Ph.D. Support Team for a compatibility check](#)