

Application Notes & Protocols: A Guide to Immunohistochemical Detection of PI3K/Akt Pathway Inhibition

Author: BenchChem Technical Support Team. **Date:** May 2026

Compound of Interest

Compound Name: PI3K/Akt-IN-1

Cat. No.: B12421190

[Get Quote](#)

Introduction: The Critical Role of the PI3K/Akt Pathway in Disease and Drug Discovery

The Phosphoinositide 3-kinase (PI3K)/Akt signaling pathway is a central regulator of fundamental cellular processes, including cell growth, proliferation, survival, and metabolism.[1] Its aberrant activation is a frequent event in a wide range of human malignancies, driving tumor progression and resistance to therapy.[2][3][4] Consequently, this pathway has emerged as a highly attractive target for the development of novel cancer therapeutics.[5]

Immunohistochemistry (IHC) provides an indispensable tool for researchers and drug development professionals to visualize and assess the activation status of the PI3K/Akt pathway directly within the tissue microenvironment. By detecting key phosphorylated proteins, IHC allows for the spatial localization of pathway activity, providing crucial insights into drug efficacy and mechanisms of action. This guide offers a comprehensive, field-proven protocol for the reliable detection of PI3K/Akt pathway inhibition in formalin-fixed, paraffin-embedded (FFPE) tissues, with a focus on the critical downstream effector, phosphorylated Akt (p-Akt).

Understanding the Target: The PI3K/Akt Signaling Cascade

Activation of the PI3K/Akt pathway is initiated by upstream signals, such as growth factors binding to receptor tyrosine kinases (RTKs). This leads to the activation of PI3K, which then phosphorylates phosphatidylinositol (4,5)-bisphosphate (PIP₂) to generate phosphatidylinositol (3,4,5)-trisphosphate (PIP₃). PIP₃ acts as a second messenger, recruiting Akt to the cell membrane where it is subsequently phosphorylated at two key residues: Threonine 308 (Thr308) and Serine 473 (Ser473). Full activation of Akt requires phosphorylation at both sites, enabling it to phosphorylate a multitude of downstream substrates, thereby regulating diverse cellular functions.

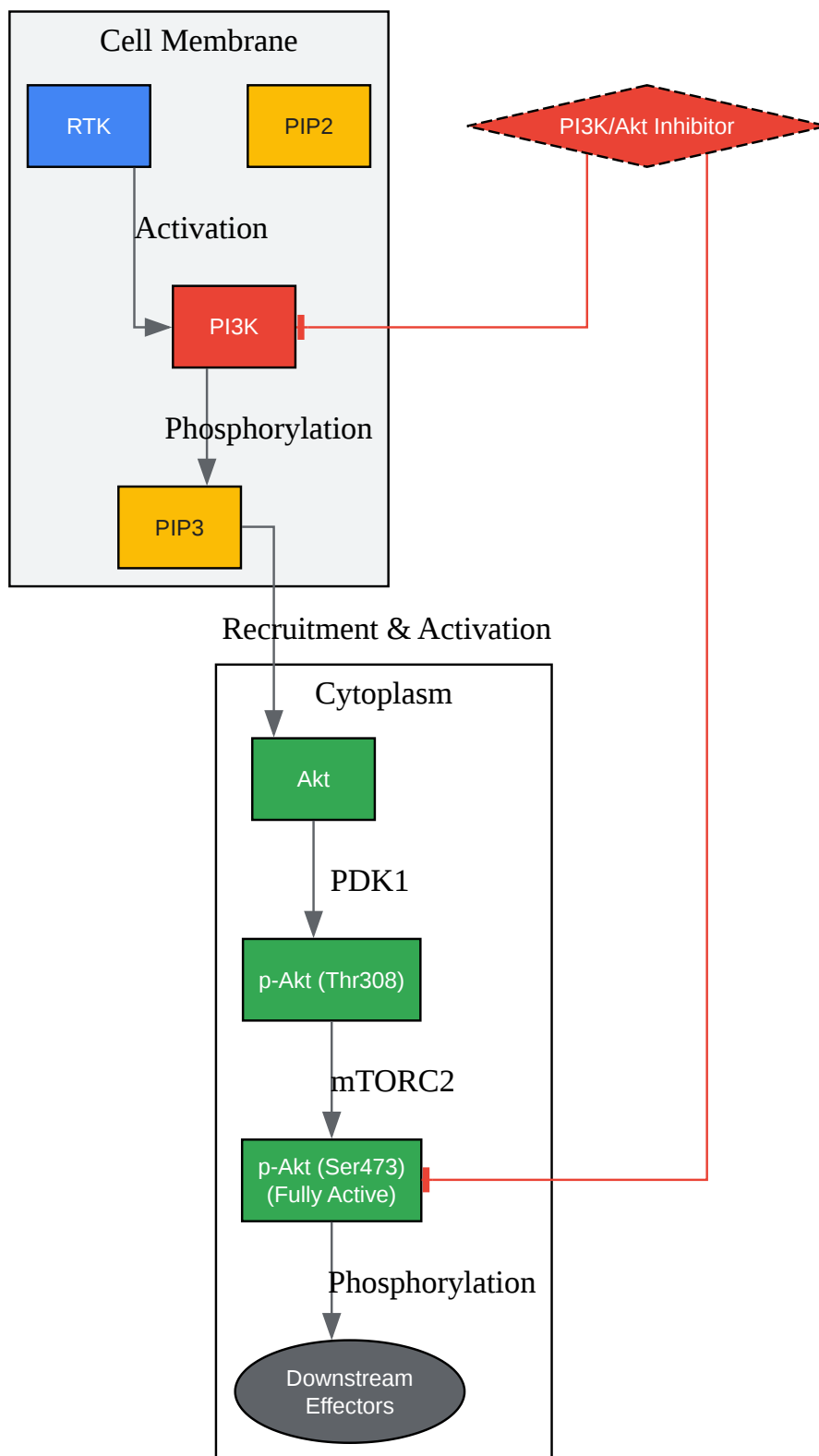

[Click to download full resolution via product page](#)

Caption: The PI3K/Akt Signaling Pathway and Points of Inhibition.

The Cornerstone of a Reliable Protocol: A Self-Validating System

A robust IHC protocol is not merely a series of steps but a self-validating system. This is achieved through the meticulous selection of antibodies, rigorous optimization of each protocol step, and the inclusion of appropriate controls. The ultimate goal is to generate data that is both specific and reproducible.

Key Markers for Assessing Pathway Inhibition

While multiple nodes in the pathway can be assessed, the phosphorylation of Akt at Serine 473 (p-Akt Ser473) is a widely accepted and critical indicator of pathway activation.^{[6][7]} A decrease in p-Akt (Ser473) staining following treatment with a PI3K/Akt pathway inhibitor is a direct measure of target engagement and pharmacological effect. Other valuable markers include phosphorylated S6 ribosomal protein (pS6), a downstream effector of the mTOR pathway which is often co-activated with Akt.^{[8][9]}

Detailed Step-by-Step Methodology

This protocol is optimized for FFPE tissues.

Sample Preparation and Fixation

The quality of the starting material is paramount. To preserve the transient nature of protein phosphorylation, prompt and proper fixation is crucial.

- Rationale: Aldehyde-based fixatives like 10% neutral buffered formalin (NBF) create cross-links between proteins, preserving tissue architecture.^{[10][11]} However, prolonged fixation can mask antigenic epitopes, hindering antibody binding.^[11]
- Protocol:
 - Immediately following excision, immerse tissue specimens in 10% NBF. The volume of fixative should be at least 10 times the volume of the tissue.
 - Fix for 18-24 hours at room temperature.^[11] Avoid fixation times exceeding 48 hours.

- Following fixation, transfer the tissue to 70% ethanol for storage prior to processing and paraffin embedding.[11]
- Standard paraffin embedding procedures should then be followed.[12]

Deparaffinization and Rehydration

- Rationale: Paraffin must be removed to allow aqueous reagents to infiltrate the tissue.
- Protocol:
 - Deparaffinize slides in xylene or a xylene substitute (2 changes, 5 minutes each).
 - Rehydrate through a graded series of ethanol: 100% (2 changes, 3 minutes each), 95% (1 change, 3 minutes), and 70% (1 change, 3 minutes).
 - Rinse in distilled water for 5 minutes.

Antigen Retrieval: Unmasking the Epitope

- Rationale: Formalin fixation-induced protein cross-links can obscure the target epitope.[13] Heat-Induced Epitope Retrieval (HIER) uses heat and a specific buffer to break these cross-links, exposing the antigen for antibody binding.[13][14] The choice of retrieval solution and pH is critical and often antibody-dependent. For many phospho-specific antibodies, a slightly acidic pH is optimal.[15]
- Protocol:
 - Pre-heat a sufficient volume of IHC Antigen Retrieval Solution (e.g., Citrate Buffer, pH 6.0) in a pressure cooker or microwave to 95-100°C.[13][15]
 - Immerse the slides in the pre-heated solution, ensuring they are completely submerged.
 - Heat for 15-20 minutes, maintaining a sub-boiling temperature.[14][15]
 - Allow the slides to cool in the retrieval solution for at least 20 minutes at room temperature.[15]

- Rinse slides in 1X Phosphate Buffered Saline (PBS) for 5 minutes.

Blocking Steps: Minimizing Background Noise

- Rationale: Blocking endogenous enzyme activity and non-specific protein binding is essential to prevent background staining and ensure the signal observed is specific to the target antigen.
- Protocol:
 - Endogenous Peroxidase Quenching: (For chromogenic detection using HRP) Incubate slides in 3% hydrogen peroxide in methanol for 10-15 minutes at room temperature.[16] This step is critical for tissues with high endogenous peroxidase activity, such as those containing red blood cells.[17]
 - Endogenous Biotin Blocking: (If using a biotin-based detection system) Some tissues, like kidney and liver, have high levels of endogenous biotin which can cause non-specific background.[18][19] If necessary, perform an avidin-biotin blocking step according to the manufacturer's instructions.[19]
 - Protein Block: Incubate slides with a protein-based blocking solution (e.g., 5% normal goat serum in PBS or a commercial blocking buffer) for 1 hour at room temperature in a humidified chamber.[20] The species of the serum should match the species of the secondary antibody.

Primary Antibody Incubation

- Rationale: This is the most critical step for specificity. The primary antibody must be well-validated for IHC and specific for the phosphorylated form of the target protein. It is imperative to perform an initial antibody titration to determine the optimal dilution that provides strong specific staining with minimal background.
- Protocol:
 - Dilute the primary antibody (e.g., Rabbit anti-p-Akt Ser473) to its predetermined optimal concentration in an appropriate antibody diluent.

- Carefully apply the diluted primary antibody to the tissue sections, ensuring complete coverage.
- Incubate overnight at 4°C in a humidified chamber. This often yields a better signal-to-noise ratio than shorter, room temperature incubations.
- The following day, wash the slides three times in 1X PBS with 0.05% Tween-20 for 5 minutes each.

Detection System

- Rationale: The detection system visualizes the location of the primary antibody. Both chromogenic and fluorescent methods can be used. Chromogenic detection, using an enzyme-conjugated secondary antibody and a substrate that produces a colored precipitate (e.g., DAB), is common for single-plex IHC and provides a permanent record.[\[21\]](#) Fluorescent detection offers advantages for multiplexing, allowing the simultaneous visualization of multiple targets.[\[22\]](#)[\[23\]](#)
- Chromogenic Detection (HRP-Polymer System) Protocol:
 - Incubate slides with a polymer-based HRP-conjugated secondary antibody (anti-rabbit) for 30-60 minutes at room temperature.
 - Wash slides three times in 1X PBS with 0.05% Tween-20 for 5 minutes each.
 - Prepare the chromogen substrate (e.g., DAB) according to the manufacturer's instructions.
 - Incubate slides with the DAB solution until the desired staining intensity is reached (typically 1-10 minutes). Monitor this step under a microscope.
 - Immediately stop the reaction by immersing the slides in distilled water.

Counterstaining, Dehydration, and Mounting

- Rationale: Counterstaining provides contrast to the specific staining, allowing for visualization of tissue morphology.
- Protocol:

- Lightly counterstain with hematoxylin for 30-60 seconds.
- "Blue" the hematoxylin by rinsing in running tap water.
- Dehydrate the slides through a graded series of ethanol (70%, 95%, 100%).
- Clear in xylene or a substitute.
- Mount with a permanent mounting medium and coverslip.



[Click to download full resolution via product page](#)

Caption: Experimental Workflow for IHC Detection of p-Akt.

Building a Self-Validating System: Essential Controls

The inclusion of appropriate controls is non-negotiable for validating the specificity of the staining and the interpretation of the results.

Control Type	Purpose	Implementation	Expected Outcome
Positive Tissue Control	To confirm that the protocol and reagents are working correctly.	Use a tissue known to express high levels of the target protein (e.g., a relevant cancer cell line xenograft with a known activating mutation in the PI3K pathway).	Strong, specific staining in the expected cellular compartment (e.g., cytoplasm and/or nucleus for p-Akt).
Negative Tissue Control	To confirm the specificity of the primary antibody.	Use a tissue known to lack the target protein.	No staining should be observed.
No Primary Antibody Control	To check for non-specific binding of the secondary antibody or detection system.	Omit the primary antibody incubation step and run the rest of the protocol.	No staining should be observed.
Isotype Control	To ensure the observed staining is not due to non-specific Fc receptor binding or other interactions of the primary antibody's isotype.	Use a non-immune antibody of the same isotype and at the same concentration as the primary antibody.	No or minimal background staining.
Biological Controls (Critical for Inhibition Studies)	To demonstrate the pharmacological effect of the inhibitor.	Include tissue sections from animals/cells treated with the vehicle control and tissue sections from animals/cells treated with the PI3K/Akt inhibitor.	A clear reduction or absence of staining for the target phosphoprotein (e.g., p-Akt) in the inhibitor-treated group compared to the vehicle-treated group. [24]

Data Interpretation and Quantitative Analysis

Qualitative assessment involves evaluating the intensity and localization of the staining. For p-Akt, a positive signal is typically observed in the cytoplasm and/or nucleus. Inhibition is demonstrated by a marked decrease in staining intensity in the treated samples compared to controls.

For a more objective assessment, semi-quantitative scoring methods can be employed.^[5] A common approach is the H-score, which combines both the intensity of the staining and the percentage of positive cells.

H-Score = $\Sigma (I \times PC)$ Where:

- I = Intensity score (e.g., 0 = no staining, 1 = weak, 2 = moderate, 3 = strong)
- PC = Percentage of cells at that intensity

Treatment Group	Intensity Score (I)	Percentage of Positive Cells (PC)	H-Score (Example Calculation)	Interpretation
Vehicle Control	3 (Strong)	70%	$(3 * 70) + (2 * 20) + (1 * 10) = 260$	High PI3K/Akt pathway activity.
	2 (Moderate)	20%		
	1 (Weak)	10%		
Inhibitor Treated	3 (Strong)	0%	$(3 * 0) + (2 * 5) + (1 * 25) = 35$	Significant pathway inhibition.
	2 (Moderate)	5%		
	1 (Weak)	25%		

Troubleshooting Common Issues

Issue	Possible Cause(s)	Suggested Solution(s)
No Staining or Weak Signal	Inactive primary antibody	Use a new, validated antibody. Confirm positive control staining.
Inefficient antigen retrieval	Optimize retrieval time, temperature, and buffer pH.	
Insufficient primary antibody concentration	Perform an antibody titration to find the optimal dilution.	
High Background	Non-specific antibody binding	Increase blocking time or use a different blocking reagent.
Endogenous peroxidase/biotin activity	Ensure blocking steps were performed correctly.	
Primary antibody concentration too high	Titrate the primary antibody to a lower concentration.	
Non-specific Staining	Cross-reactivity of primary or secondary antibody	Run appropriate negative and isotype controls. Use affinity-purified antibodies.

For a more detailed troubleshooting guide, resources from vendors like Boster Bio can be very helpful.[\[25\]](#)

Conclusion

This application note provides a robust and validated framework for the immunohistochemical assessment of PI3K/Akt pathway inhibition. By understanding the scientific principles behind each step, from tissue fixation to data interpretation, and by incorporating a comprehensive set of controls, researchers can generate reliable and reproducible data. This, in turn, will facilitate a deeper understanding of the biological effects of PI3K/Akt inhibitors and accelerate the development of more effective targeted therapies.

References

- Judson, R. et al. (2015). Measuring PI3K Activation: Clinicopathologic, Immunohistochemical, and RNA Expression Analysis in Prostate Cancer. *Molecular Cancer Research*. Available at: [\[Link\]](#)
- Cell Signaling Technology. (2018). How to perform Antigen Retrieval (AR) in Immunohistochemistry (IHC) | CST Tech Tips. YouTube. Available at: [\[Link\]](#)
- Lee, M. S. et al. (2015). PI3K/AKT Signaling Is Essential for Communication between Tissue-Infiltrating Mast Cells, Macrophages, and Epithelial Cells in Colitis-Induced Cancer. *Cancer Research*. Available at: [\[Link\]](#)
- Creative Diagnostics. (2021). The Method of IHC Antigen Retrieval. Available at: [\[Link\]](#)
- El-Far, A. H. et al. (2023). SIRT3, NF- κ B/TNF- α and PI3K/Akt Pathways Mediate the Hepatoprotective Activity of Gossypin Against Concanavalin A-Induced Hepatic Fibrosis. *MDPI*. Available at: [\[Link\]](#)
- Laukhtina, E. et al. (2022). Assessment of PI3K/mTOR/AKT Pathway Elements to Serve as Biomarkers and Therapeutic Targets in Penile Cancer. *Cancers*. Available at: [\[Link\]](#)
- Nobre, M. (2023). Response to "IHC with phospho polyclonal antibodies -- special considerations?". ResearchGate. Available at: [\[Link\]](#)
- Gee, J. M. W. et al. (2008). Immunohistochemical analysis of changes in signaling pathway activation downstream of growth factor receptors in pancreatic duct cell carcinogenesis. *BMC Cancer*. Available at: [\[Link\]](#)
- Al-Jany, B. et al. (2018). Enhancing Antigen Retrieval To Unmask Signaling Phosphoproteins In Formalin-Fixed Archival Tissues. *The Journal of Histochemistry and Cytochemistry*. Available at: [\[Link\]](#)
- Desai, S. D. et al. (2018). Developing a Phosphospecific IHC Assay as a Predictive Biomarker for Topoisomerase I Inhibitors. *The Journal of Histochemistry and Cytochemistry*. Available at: [\[Link\]](#)
- Starborg, M. (2014). Preparation of formalin-fixed paraffin-embedded tissue for immunohistochemistry. *Methods in Molecular Biology*. Available at: [\[Link\]](#)

- Fierro, M. T. et al. (2020). A comprehensive immunohistochemical approach of AKT/mTOR pathway and p-STAT3 in mycosis fungoides. ResearchGate. Available at: [\[Link\]](#)
- Fresno, M. & Cuezva, J. M. (2016). Negative feedback loops in the PI3K/AKT pathway. ResearchGate. Available at: [\[Link\]](#)
- Lotan, T. L. et al. (2015). The IHC score of PI3K pathway activation is associated tumor and clinical features suggestive of more aggressive disease. ResearchGate. Available at: [\[Link\]](#)
- IHC WORLD. (n.d.). Blocking Endogenous Biotin. Available at: [\[Link\]](#)
- St John's Laboratory. (n.d.). Chromogenic and Fluorescent detection: differences and uses. Available at: [\[Link\]](#)
- Koukourakis, M. I. et al. (2005). An Immunohistochemical Evaluation of Phosphorylated Akt at Threonine 308 [pAkt(Thr308)] in Invasive Breast Cancer. In Vivo. Available at: [\[Link\]](#)
- National Society for Histotechnology. (2021). Basics of the Blocking Step in IHC. Available at: [\[Link\]](#)
- Lee, M. S. et al. (2014). PI3K/AKT signaling is essential for communication between tissue infiltrating mast cells, macrophages, and epithelial cells in colitis-induced cancer. PMC. Available at: [\[Link\]](#)
- Hasan, M. A. et al. (2023). Highlighting the Importance of Signaling Pathways and Immunohistochemistry Features in HCC: A Case Report and Literature Review. ResearchGate. Available at: [\[Link\]](#)
- Bio-Rad Antibodies. (n.d.). PI3K/AKT Cell Signaling Pathway. Available at: [\[Link\]](#)
- Biocompare. (n.d.). Phospho-Akt Immunohistochemistry Antibody Products. Available at: [\[Link\]](#)
- Antibodies.com. (n.d.). Immunohistochemistry Protocols. Available at: [\[Link\]](#)
- Judson, R. et al. (2015). Measuring PI3K Activation: Clinicopathologic, Immunohistochemical, and RNA Expression Analysis in Prostate Cancer | Request PDF.

ResearchGate. Available at: [\[Link\]](#)

- StageBio. (2018). An Overview of IHC Staining Procedures for Formalin-Fixed, Paraffin-Embedded (FFPE) Tissues. Available at: [\[Link\]](#)
- Boster Biological Technology. (n.d.). IHC Troubleshooting Guide | Common Issues & Fixes. Available at: [\[Link\]](#)
- Bio-Rad Antibodies. (n.d.). Tips for Step 6 - Block Endogenous Enzymes and Biotin. Available at: [\[Link\]](#)
- Biocompare. (2013). Tips for Optimizing IHC Staining. Available at: [\[Link\]](#)

Need Custom Synthesis?

BenchChem offers custom synthesis for rare earth carbides and specific isotopic labeling.

Email: info@benchchem.com or [Request Quote Online](#).

Sources

- 1. bio-rad-antibodies.com [bio-rad-antibodies.com]
- 2. aacrjournals.org [aacrjournals.org]
- 3. researchgate.net [researchgate.net]
- 4. researchgate.net [researchgate.net]
- 5. Assessment of PI3K/mTOR/AKT Pathway Elements to Serve as Biomarkers and Therapeutic Targets in Penile Cancer - PMC [[pmc.ncbi.nlm.nih.gov](https://pubmed.ncbi.nlm.nih.gov/)]
- 6. Phospho-Akt (Ser473) Antibody (IHC Specific) | Cell Signaling Technology [[cellsignal.com](https://www.cellsignal.com)]
- 7. Phospho-AKT (Ser473) antibody (28731-1-AP) | Proteintech [[ptglab.com](https://www.ptglab.com)]
- 8. Measuring PI3K Activation: Clinicopathologic, Immunohistochemical, and RNA Expression Analysis in Prostate Cancer - PMC [[pmc.ncbi.nlm.nih.gov](https://pubmed.ncbi.nlm.nih.gov/)]
- 9. researchgate.net [researchgate.net]
- 10. [creative-diagnostics.com](https://www.creative-diagnostics.com) [[creative-diagnostics.com](https://www.creative-diagnostics.com)]
- 11. [stagebio.com](https://www.stagebio.com) [[stagebio.com](https://www.stagebio.com)]

- 12. Preparation of formalin-fixed paraffin-embedded tissue for immunohistochemistry - PubMed [pubmed.ncbi.nlm.nih.gov]
- 13. IHC Antigen Retrieval | Proteintech Group [ptglab.com]
- 14. m.youtube.com [m.youtube.com]
- 15. BestProtocols: IHC FFPE Tissue Low pH Antigen Retrieval—Direct Method | Thermo Fisher Scientific - SG [thermofisher.com]
- 16. bio-rad-antibodies.com [bio-rad-antibodies.com]
- 17. Basics of the Blocking Step in IHC [nsh.org]
- 18. 内因性検出のブロック法 | Thermo Fisher Scientific - JP [thermofisher.com]
- 19. Blocking Endogenous Biotin - IHC WORLD [ihcworld.com]
- 20. rndsystems.com [rndsystems.com]
- 21. Detection and amplification systems | Abcam [abcam.com]
- 22. biossusa.com [biossusa.com]
- 23. stjohslabs.com [stjohslabs.com]
- 24. PI3K/AKT signaling is essential for communication between tissue infiltrating mast cells, macrophages, and epithelial cells in colitis-induced cancer - PMC [pmc.ncbi.nlm.nih.gov]
- 25. bosterbio.com [bosterbio.com]
- To cite this document: BenchChem. [Application Notes & Protocols: A Guide to Immunohistochemical Detection of PI3K/Akt Pathway Inhibition]. BenchChem, [2026]. [Online PDF]. Available at: [https://www.benchchem.com/product/b12421190/docs#application-notes-protocols-a-guide-to-immunohistochemical-detection-of-pi3k-akt-pathway-inhibition]

Disclaimer & Data Validity:

The information provided in this document is for Research Use Only (RUO) and is strictly not intended for diagnostic or therapeutic procedures. While BenchChem strives to provide accurate protocols, we make no warranties, express or implied, regarding the fitness of this product for every specific experimental setup.

Technical Support: The protocols provided are for reference purposes. Unsure if this reagent suits your experiment?

Need Industrial/Bulk Grade? [Request Custom Synthesis Quote](#)

BenchChem

Our mission is to be the trusted global source of essential and advanced chemicals, empowering scientists and researchers to drive progress in science and industry.

Contact

Address: 3281 E Guasti Rd
Ontario, CA 91761, United States
Phone: (601) 213-4426
Email: info@benchchem.com

[Contact our Ph.D. Support Team for a compatibility check](#)