

An In-depth Technical Guide to the Subcellular Localization of FtsZ in Prokaryotes

Author: BenchChem Technical Support Team. **Date:** April 2026

Compound of Interest

Compound Name: *Ftisadtsk*

Cat. No.: *B12421236*

[Get Quote](#)

Disclaimer: Initial searches for the protein "**Ftisadtsk**" did not yield any results in public scientific databases. This suggests the name may be a typographical error or an internal designation not yet in the public domain. To fulfill the structural and content requirements of your request, this guide will focus on the well-characterized and functionally analogous prokaryotic protein, FtsZ (Filamenting temperature-sensitive mutant Z), a critical component of the bacterial cell division machinery. The principles, protocols, and data presentation formats detailed herein can be directly adapted for your protein of interest once its identity is clarified.

Executive Summary

FtsZ, a homolog of eukaryotic tubulin, is the foundational protein of the prokaryotic cytokinetic machinery.^{[1][2]} It polymerizes at the future division site to form a contractile ring structure, known as the Z-ring, which serves as a scaffold for the recruitment of at least ten other proteins required for cell division.^{[1][3]} The precise spatial and temporal regulation of Z-ring formation is paramount for ensuring the faithful segregation of chromosomes and the generation of viable daughter cells. This guide provides a comprehensive overview of the subcellular localization of FtsZ, the key regulatory pathways that govern its positioning, and the detailed experimental protocols used for its study.

Quantitative Localization of FtsZ

The subcellular distribution of FtsZ is dynamic, shifting from a diffuse cytoplasmic state to a highly concentrated structure at the mid-cell.[3] Quantitative analysis via methods such as immunofluorescence microscopy and cell fractionation followed by Western blotting allows for the determination of the relative abundance of FtsZ in various cellular compartments.

Table 2.1: Relative Distribution of FtsZ in E. coli During Mid-Logarithmic Growth

Subcellular Fraction	Percentage of Total Cellular FtsZ (%)	Method of Determination	Key Observations
Cytoplasm (Soluble)	~70 - 80%	Cell Fractionation & Western Blot	Represents the pool of unpolymerized FtsZ monomers and short filaments.
Z-Ring (Membrane-Associated)	~20 - 30%	Super-Resolution Microscopy	Concentrated at the mid-cell; represents polymerized, active FtsZ.
Polar Regions	< 1%	Fluorescence Microscopy	Actively excluded from poles by the Min system.
Nucleoid-Associated	< 1%	Fluorescence Microscopy	Actively excluded from the nucleoid by the SImA system.

Table 2.2: Precision of Z-Ring Positioning

Organism	Z-Ring Position (Mean \pm SD from Mid-cell)	Method of Determination	Reference
E. coli	0.50 \pm 0.026 (of cell length)	Fluorescence Microscopy	Yu & Margolin, 1999
B. subtilis	0.50 \pm 0.022 (of cell length)	Fluorescence Microscopy (Live Cell)	

Signaling Pathways Regulating FtsZ Localization

The precise placement of the Z-ring at the mid-cell is not a default process but is actively controlled by negative regulatory systems that define the permissible division site. In many rod-shaped bacteria like E. coli, two primary systems are the Min system and Nucleoid Occlusion.

The Min System: Preventing Polar Z-Ring Formation

The Min system prevents FtsZ polymerization at the cell poles. It consists of three proteins: MinC, MinD, and MinE. MinC is the direct inhibitor of FtsZ polymerization. MinD is an ATPase that anchors MinC to the membrane. MinE forms a ring that stimulates MinD's ATPase activity, causing the MinCD complex to detach from the membrane and re-localize to the opposite pole. This dynamic oscillation creates a time-averaged concentration gradient of the MinC inhibitor, which is highest at the poles and lowest at the mid-cell, leaving the center as the most favorable site for Z-ring assembly.

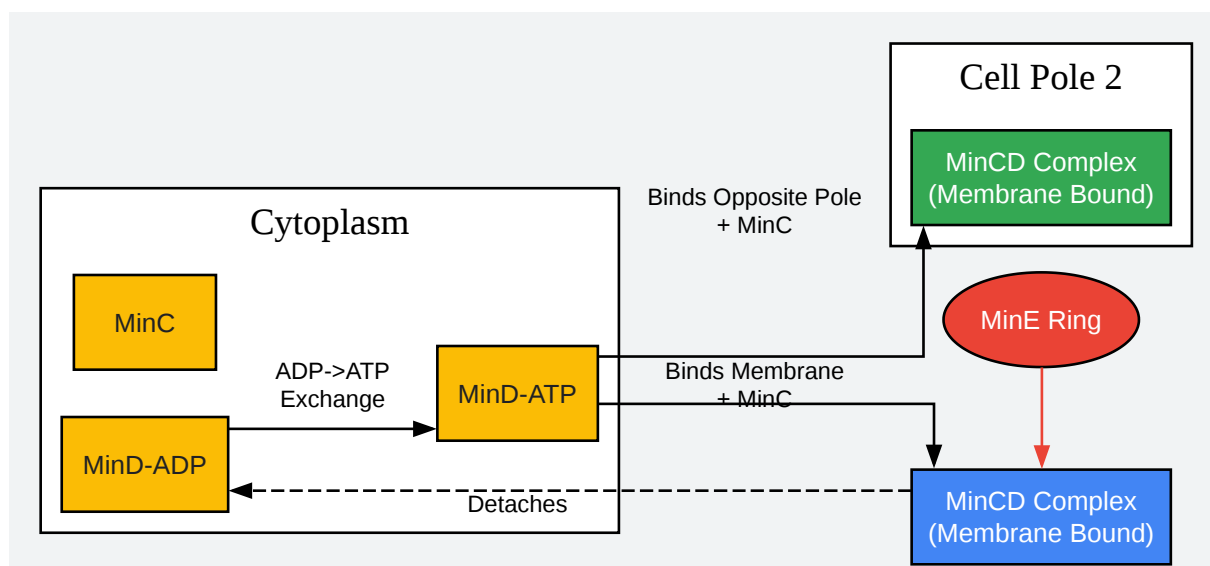

[Click to download full resolution via product page](#)

Fig 1. Oscillation of the Min system to define the mid-cell.

Nucleoid Occlusion: Preventing Chromosome Damage

The Nucleoid Occlusion (NO) system prevents the Z-ring from forming over the bacterial chromosome, thus avoiding catastrophic DNA damage during cell constriction. In *E. coli*, the effector of NO is the SlmA protein. SlmA binds to specific SlmA-binding sequences (SBS) distributed across the chromosome, but absent from the terminus region. When bound to DNA, SlmA's ability to antagonize FtsZ polymerization is dramatically enhanced, effectively preventing Z-ring assembly in the vicinity of the nucleoid. As the chromosomes are segregated towards the cell poles, the mid-cell region becomes cleared of the SlmA-DNA inhibitory signal, further licensing this area for division.

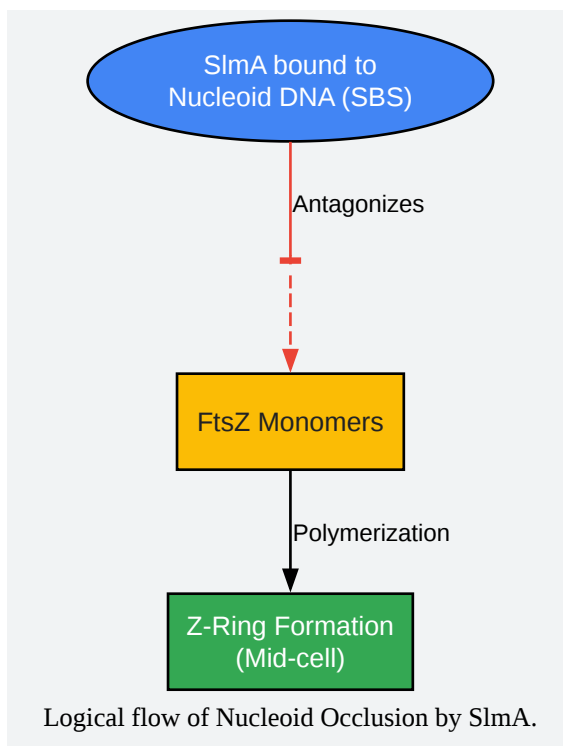

[Click to download full resolution via product page](#)

Fig 2. SlmA-mediated inhibition of FtsZ polymerization.

Experimental Protocols

Determining the subcellular localization of FtsZ relies on two primary techniques: visualizing the protein in situ via immunofluorescence microscopy and quantifying its distribution in cellular fractions.

Protocol: Immunofluorescence Microscopy for Z-Ring Visualization

This protocol allows for the direct visualization of the FtsZ ring within fixed bacterial cells.

- Cell Culture & Fixation:
 - Grow E. coli culture in LB medium to an OD600 of ~0.4-0.5.
 - Harvest 1 mL of culture by centrifugation (8000 x g, 1 min).
 - Wash the cell pellet three times with 1x Phosphate-Buffered Saline (PBS).

- Fix the cells by resuspending the pellet in 0.5 mL of 1x PBS containing 4% paraformaldehyde and incubate for 20 minutes at room temperature.
- Wash the fixed cells twice with 1x PBS to remove the fixative.
- Permeabilization & Blocking:
 - Resuspend the fixed cells in 100 μ L of GTE buffer (50 mM glucose, 20 mM Tris-HCl pH 7.5, 10 mM EDTA) containing 2 mg/mL lysozyme. Incubate for 5 minutes at room temperature to permeabilize the cell wall.
 - Apply 20 μ L of the cell suspension to a poly-L-lysine coated microscope slide and allow it to air-dry completely.
 - Immerse the slide in methanol at -20°C for 5 minutes, followed by acetone at -20°C for 30 seconds. Air dry.
 - Block the sample by adding blocking buffer (PBS with 2% Bovine Serum Albumin) and incubate for 30 minutes in a humidified chamber.
- Antibody Staining:
 - Dilute the primary antibody (e.g., rabbit anti-FtsZ) in blocking buffer.
 - Remove the blocking buffer from the slide and add the diluted primary antibody. Incubate for 1-2 hours at room temperature in a humidified chamber.
 - Wash the slide three times for 5 minutes each with PBS.
 - Dilute the fluorescently-labeled secondary antibody (e.g., goat anti-rabbit IgG-Alexa Fluor 488) in blocking buffer.
 - Add the secondary antibody and incubate for 1 hour at room temperature, protected from light.
 - Wash the slide three times for 5 minutes each with PBS, protected from light.
- Mounting & Imaging:

- Add a drop of antifade mounting medium to the slide and place a coverslip on top.
- Seal the coverslip and image using a fluorescence microscope with appropriate filters.

Protocol: Cell Fractionation by Differential Centrifugation

This protocol separates prokaryotic cells into cytoplasmic, membrane, and periplasmic fractions to quantify protein distribution.

- Spheroplast Formation & Periplasmic Extraction:
 - Harvest mid-log phase cells by centrifugation (5,000 x g, 10 min, 4°C).
 - Resuspend the pellet in a cold sucrose buffer (e.g., 20% sucrose, 30 mM Tris-HCl, 1 mM EDTA, pH 8.0).
 - Add lysozyme to a final concentration of 0.5 mg/mL and incubate on ice for 30 minutes. This creates spheroplasts.
 - Pellet the spheroplasts by centrifugation (8,000 x g, 15 min, 4°C). The supernatant contains the periplasmic fraction.
- Spheroplast Lysis & Fraction Separation:
 - Resuspend the spheroplast pellet in a cold, hypotonic lysis buffer (e.g., 50 mM Tris-HCl, 5 mM MgCl₂, pH 7.5) containing protease inhibitors and DNase I.
 - Lyse the spheroplasts via sonication on ice.
 - Perform a low-speed centrifugation (1,000 x g, 5 min, 4°C) to pellet any unlysed cells. Retain the supernatant.
 - To separate the membrane and cytoplasmic fractions, subject the supernatant to ultracentrifugation (e.g., 100,000 x g, 1 hour, 4°C).
 - The resulting supernatant is the cytoplasmic (soluble) fraction. The pellet contains the total membrane fraction.

- Analysis:
 - Analyze equal protein amounts from each fraction (Total Cell Lysate, Periplasmic, Cytoplasmic, Membrane) by SDS-PAGE and Western blotting using an anti-FtsZ antibody to determine the relative abundance in each compartment.

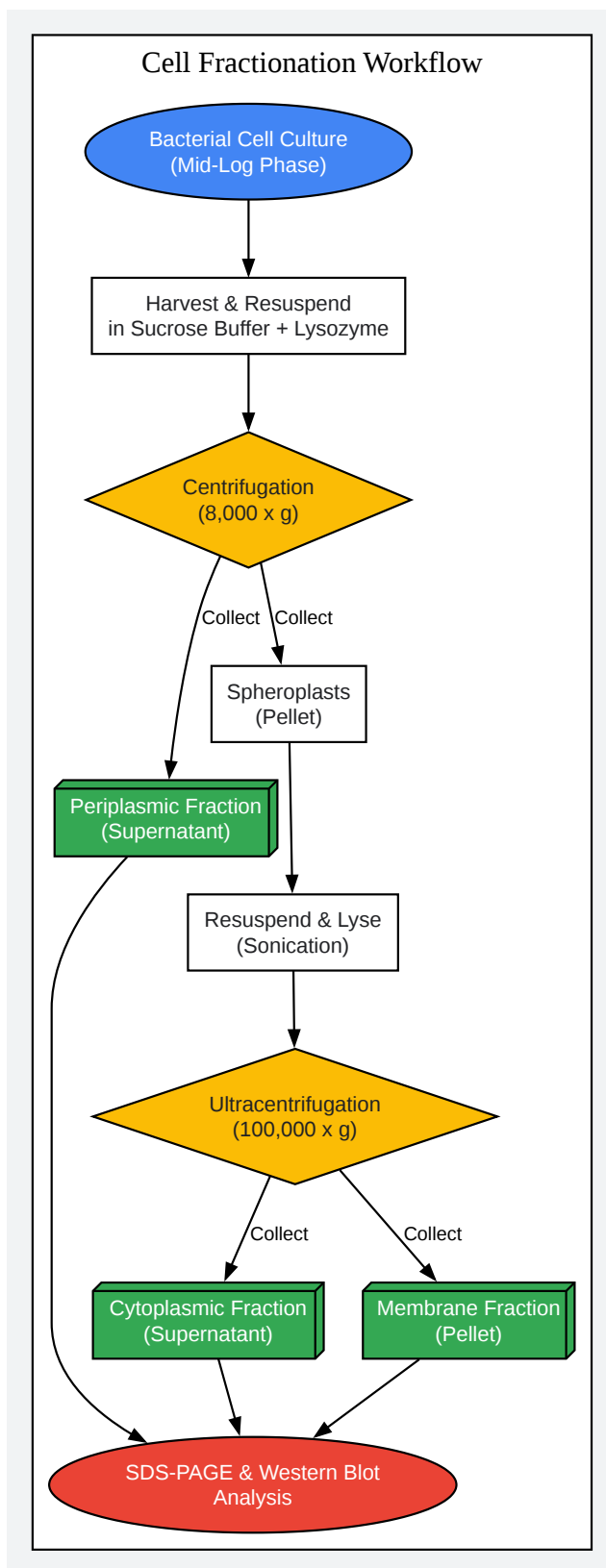

[Click to download full resolution via product page](#)

Fig 3. Workflow for prokaryotic subcellular fractionation.

Need Custom Synthesis?

BenchChem offers custom synthesis for rare earth carbides and specific isotopic labeling.

Email: info@benchchem.com or [Request Quote Online](#).

References

- [1. FTSZ AND THE DIVISION OF PROKARYOTIC CELLS AND ORGANELLES - PMC \[pmc.ncbi.nlm.nih.gov\]](#)
- [2. FtsZ - Wikipedia \[en.wikipedia.org\]](#)
- [3. FtsZ \(protein\) | Research Starters | EBSCO Research \[ebSCO.com\]](#)
- To cite this document: BenchChem. [An In-depth Technical Guide to the Subcellular Localization of FtsZ in Prokaryotes]. BenchChem, [2026]. [Online PDF]. Available at: [\[https://www.benchchem.com/product/b12421236/docs#an-in-depth-technical-guide-to-the-subcellular-localization-of-ftsZ-in-prokaryotes\]](https://www.benchchem.com/product/b12421236/docs#an-in-depth-technical-guide-to-the-subcellular-localization-of-ftsZ-in-prokaryotes)

Disclaimer & Data Validity:

The information provided in this document is for Research Use Only (RUO) and is strictly not intended for diagnostic or therapeutic procedures. While BenchChem strives to provide accurate protocols, we make no warranties, express or implied, regarding the fitness of this product for every specific experimental setup.

Technical Support: The protocols provided are for reference purposes. Unsure if this reagent suits your experiment?

Need Industrial/Bulk Grade? [Request Custom Synthesis Quote](#)

BenchChem

Our mission is to be the trusted global source of essential and advanced chemicals, empowering scientists and researchers to drive progress in science and industry.

Contact

Address: 3281 E Guasti Rd

Ontario, CA 91761, United States

Phone: (601) 213-4426

Email: info@benchchem.com

[Contact our Ph.D. Support Team for a compatibility check](#)