

Application Notes and Protocols for GSD-11 Cell Migration Assays

Author: BenchChem Technical Support Team. **Date:** April 2026

Compound of Interest

Compound Name: GSD-11
Cat. No.: B12420166

[Get Quote](#)

For Researchers, Scientists, and Drug Development Professionals

Introduction

Cell migration is a fundamental biological process implicated in a myriad of physiological and pathological events, including embryonic development, immune response, wound healing, and cancer metastasis.[1][2] The study of signaling molecules that regulate cell migration is crucial for understanding these processes and for the development of novel therapeutic strategies. These application notes provide detailed protocols for investigating the role of the hypothetical protein **GSD-11** in cell migration using two widely adopted in vitro methods: the Scratch Wound Healing Assay and the Transwell Migration Assay. Additionally, a plausible signaling pathway for **GSD-11**'s role in cell migration is presented, drawing parallels with known signaling proteins.

Hypothetical Signaling Pathway of GSD-11 in Cell Migration

GSD-11 is hypothesized to be a key regulator of cell migration. Upon activation by upstream signals, such as growth factors, **GSD-11** may initiate a signaling cascade that ultimately

modulates the cytoskeletal rearrangements necessary for cell motility. A potential pathway involves the activation of small GTPases, like Rac1, which are known to be central players in cell migration.[1][3] Activation of Rac1 can lead to a cascade involving c-Raf, ERK, and FAK, which are crucial for the dynamic regulation of focal adhesions and the actin cytoskeleton, driving cell movement.[3][4]

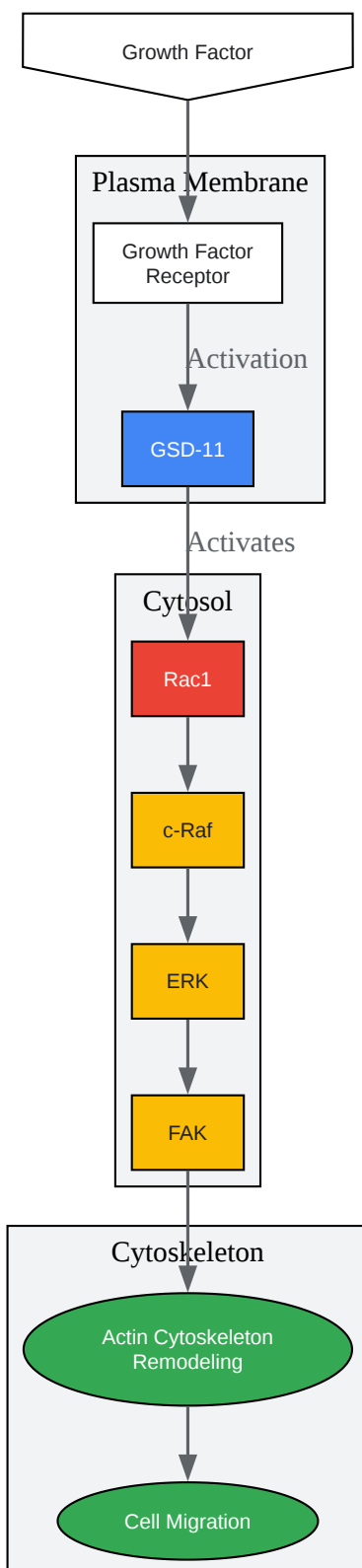

[Click to download full resolution via product page](#)

Caption: Hypothetical **GSD-11** signaling pathway in cell migration.

Experimental Protocols

Two primary methods for assessing cell migration in vitro are the scratch wound healing assay and the transwell migration assay.

Scratch Wound Healing Assay

The scratch wound healing assay is a straightforward and economical method to study collective cell migration.[5] It involves creating a "wound" in a confluent cell monolayer and monitoring the rate at which the cells migrate to close the gap.[5][6]

Experimental Workflow:

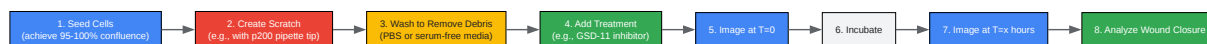

[Click to download full resolution via product page](#)

Caption: Workflow for the scratch wound healing assay.

Detailed Protocol:

- Cell Seeding:
 - Culture cells of interest in a 6-well or 12-well plate until they form a confluent monolayer (90-100%).[6][7] The seeding density should be optimized for the specific cell line to achieve confluence within 24-48 hours.[6]
- Creating the Wound:
 - Once confluent, use a sterile p200 pipette tip to create a straight scratch across the center of the cell monolayer.[6] Apply consistent pressure to ensure a uniform wound width.
- Washing:
 - Gently wash the wells two to three times with sterile phosphate-buffered saline (PBS) or serum-free medium to remove detached cells and debris.[6]

- Treatment and Incubation:
 - Replace the wash solution with fresh culture medium, with or without the **GSD-11** modulating compound being tested.
 - Place the plate in an incubator at 37°C and 5% CO₂.
- Imaging:
 - Capture images of the scratch at the beginning of the experiment (T=0) and at regular intervals (e.g., every 4-8 hours) until the wound is nearly closed in the control group.[7] Using a microscope with a camera is essential.
- Data Analysis:
 - The rate of cell migration is quantified by measuring the area or width of the scratch at different time points and calculating the percentage of wound closure relative to the initial wound area.

Data Presentation:

Treatment Group	Initial Wound Area (µm ²)	Final Wound Area (µm ²)	Percent Wound Closure
Control	500,000	150,000	70%
GSD-11 Inhibitor (10 µM)	500,000	400,000	20%
GSD-11 Overexpression	500,000	50,000	90%

Transwell Migration Assay (Boyden Chamber Assay)

The transwell migration assay assesses the chemotactic capability of cells to migrate through a porous membrane towards a chemoattractant.[8][9] This assay is particularly useful for studying the migration of individual cells.[5]

Experimental Workflow:



[Click to download full resolution via product page](#)

Need Custom Synthesis?

BenchChem offers custom synthesis for rare earth carbides and specific isotopic labeling.

Email: info@benchchem.com or [Request Quote Online](#).

References

- [1. cdr.lib.unc.edu \[cdr.lib.unc.edu\]](http://cdr.lib.unc.edu)
- [2. reactionbiology.com \[reactionbiology.com\]](http://reactionbiology.com)
- [3. oncotarget.com \[oncotarget.com\]](http://oncotarget.com)
- [4. Overexpression of regulator of G protein signaling 11 promotes cell migration and associates with advanced stages and aggressiveness of lung adenocarcinoma - PubMed \[pubmed.ncbi.nlm.nih.gov\]](#)
- [5. Wound healing assay | Abcam \[abcam.com\]](#)
- [6. clyte.tech \[clyte.tech\]](http://clyte.tech)
- [7. med.virginia.edu \[med.virginia.edu\]](http://med.virginia.edu)
- [8. In vitro Cell Migration and Invasion Assays - PMC \[pmc.ncbi.nlm.nih.gov\]](#)
- [9. Cell Migration & Invasion Assays \[sigmaaldrich.com\]](http://sigmaaldrich.com)
- To cite this document: BenchChem. [Application Notes and Protocols for GSD-11 Cell Migration Assays]. BenchChem, [2026]. [Online PDF]. Available at: [\[https://www.benchchem.com/product/b12420166/docs#application-notes-and-protocols-for-gsd-11-cell-migration-assays\]](https://www.benchchem.com/product/b12420166/docs#application-notes-and-protocols-for-gsd-11-cell-migration-assays)

Disclaimer & Data Validity:

The information provided in this document is for Research Use Only (RUO) and is strictly not intended for diagnostic or therapeutic procedures. While BenchChem strives to provide accurate protocols, we make no warranties, express or implied, regarding the fitness of this product for every specific experimental setup.

Technical Support: The protocols provided are for reference purposes. Unsure if this reagent suits your experiment?

Need Industrial/Bulk Grade? [Request Custom Synthesis Quote](#)

BenchChem

Our mission is to be the trusted global source of essential and advanced chemicals, empowering scientists and researchers to drive progress in science and industry.

Contact

Address: 3281 E Guasti Rd
Ontario, CA 91761, United States
Phone: (601) 213-4426
Email: info@benchchem.com

[Contact our Ph.D. Support Team for a compatibility check](#)