

The Binding Profile of (+)-Desflurane: A Technical Guide

Author: BenchChem Technical Support Team. **Date:** April 2026

Compound of Interest

Compound Name: (+)-Desflurane

CAS No.: 142916-68-5

Cat. No.: B1242257

[Get Quote](#)

For Researchers, Scientists, and Drug Development Professionals

Introduction

Desflurane, a widely used volatile anesthetic, is a racemic mixture of two enantiomers: (R)-(-)-Desflurane and (S)-**(+)-Desflurane**. While the anesthetic properties of the racemate are well-documented, a deeper understanding of the specific interactions of each enantiomer with neuronal targets is crucial for the development of more refined and safer anesthetic agents. This technical guide provides an in-depth exploration of the binding profile of the (+)-enantiomer of Desflurane, which has been determined to possess the (S)-configuration. The primary mechanism of action for desflurane involves the positive allosteric modulation of γ -aminobutyric acid type A (GABA-A) receptors and the inhibition of N-methyl-D-aspartate (NMDA) receptors.[1][2] This document summarizes the available quantitative data, details key experimental methodologies used to elucidate these interactions, and presents visual representations of the relevant signaling pathways and experimental workflows.

Data Presentation: Quantitative Binding Profile

Quantitative data on the binding affinity of **(+)-Desflurane** for its various molecular targets remains limited in publicly available literature. Most studies have been conducted using the racemic mixture. The following table summarizes the available quantitative data for racemic Desflurane. It is important to note that the stereoselectivity of desflurane's interactions can be target-dependent, with some studies on cardiac ion channels showing no significant difference between the enantiomers, while effects on neuronal channels may exhibit stereospecificity.[3] [4]

Target Receptor	Ligand	Parameter	Value	Species/System	Reference
NMDA Receptor (NR1/NR2A Subtype)	Racemic Desflurane	IC50	1.18 ± 0.03 MAC	Recombinantly expressed in Xenopus oocytes	[2]
NMDA Receptor (NR1/NR2B Subtype)	Racemic Desflurane	IC50	1.22 ± 0.08 MAC	Recombinantly expressed in Xenopus oocytes	[2]

Note: MAC (Minimum Alveolar Concentration) is a measure of anesthetic potency. 1 MAC of Desflurane is approximately 6.6% in adults.[5] The IC50 values are presented in multiples of MAC.

Signaling Pathways

The anesthetic effects of **(+)-Desflurane** are primarily mediated through its interaction with inhibitory and excitatory neurotransmitter receptors in the central nervous system.

Positive Allosteric Modulation of GABA-A Receptors

(+)-Desflurane enhances the function of GABA-A receptors, the primary inhibitory neurotransmitter receptors in the brain.[1] It binds to a site on the receptor distinct from the GABA binding site and allosterically increases the receptor's affinity for GABA. This leads to an increased frequency and/or duration of chloride (Cl⁻) channel opening, resulting in an influx of Cl⁻ ions.[1] The increased intracellular Cl⁻ concentration hyperpolarizes the neuron, making it

less likely to fire an action potential and thus leading to neuronal inhibition and the state of anesthesia.[1]

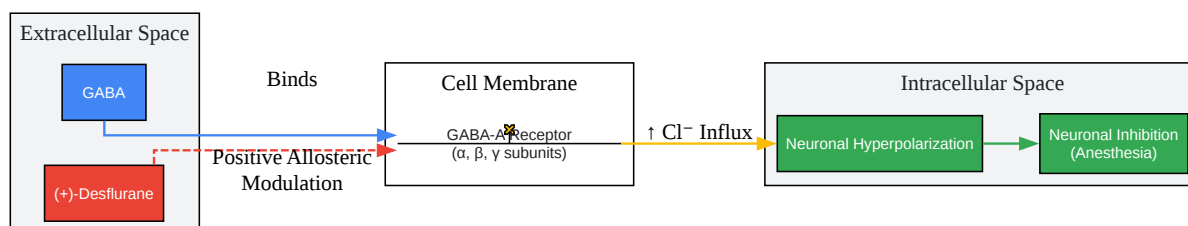

[Click to download full resolution via product page](#)

Signaling pathway of **(+)-Desflurane**'s action on the GABA-A receptor.

Antagonism of NMDA Receptors

(+)-Desflurane also contributes to anesthesia by inhibiting the function of NMDA receptors, which are critical for excitatory neurotransmission.[2] It acts as a non-competitive antagonist, meaning it does not compete with the binding of the neurotransmitters glutamate and glycine. [6] By binding to an allosteric site, **(+)-Desflurane** reduces the efficiency of channel opening, thereby decreasing the influx of calcium (Ca²⁺) and sodium (Na⁺) ions. This reduction in excitatory signaling contributes to the overall anesthetic state.

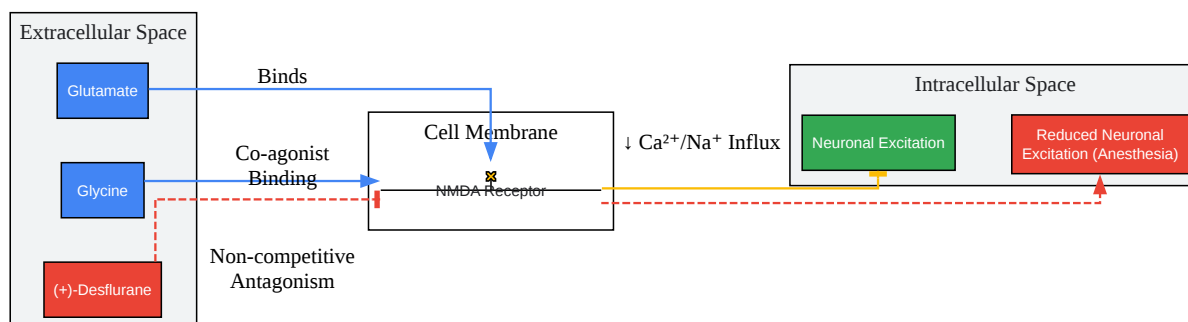

[Click to download full resolution via product page](#)

Signaling pathway of **(+)-Desflurane**'s antagonism of the NMDA receptor.

Experimental Protocols

The investigation of **(+)-Desflurane**'s binding profile relies on a combination of sophisticated experimental techniques.

Whole-Cell Patch-Clamp Electrophysiology

This is the primary technique for characterizing the functional effects of anesthetics on ion channels.

Protocol Outline:

- **Cell Culture and Transfection:** A suitable cell line, such as Human Embryonic Kidney (HEK293) cells, is cultured. These cells are then transiently or stably transfected with the cDNAs encoding the subunits of the target receptor (e.g., specific GABA-A or NMDA receptor subunits).[1]
- **Electrode Preparation:** Borosilicate glass capillaries are pulled to create micropipettes with a tip diameter of approximately 1-2 μm . The micropipette is filled with an internal solution that mimics the intracellular ionic composition.

- **Gigaohm Seal Formation:** The micropipette is brought into contact with the cell membrane, and gentle suction is applied to form a high-resistance (gigaohm) seal between the pipette tip and the cell membrane.
- **Whole-Cell Configuration:** A brief pulse of suction is applied to rupture the patch of membrane under the pipette tip, establishing electrical and diffusive access to the cell's interior.
- **Voltage Clamp and Data Acquisition:** The cell is voltage-clamped at a specific holding potential (e.g., -60 mV). The agonist (e.g., GABA or glutamate/glycine) is applied to elicit an ionic current.
- **Anesthetic Application:** A solution containing **(+)-Desflurane** at a known concentration is perfused over the cell, and the effect on the agonist-elicited current is recorded. Potentiation (for GABA-A receptors) or inhibition (for NMDA receptors) of the current is quantified.[1]

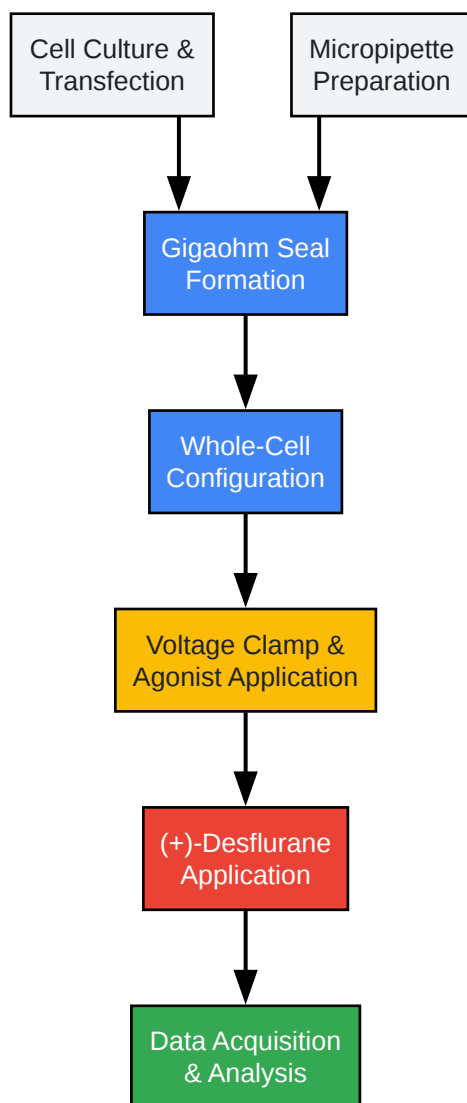

[Click to download full resolution via product page](#)

Experimental workflow for whole-cell patch-clamp electrophysiology.

Site-Directed Mutagenesis

This technique is employed to identify specific amino acid residues within the receptor that are critical for anesthetic binding and modulation.

Protocol Outline:

- **Primer Design:** Mutagenic oligonucleotide primers are designed. These primers contain the desired mutation (a change in the nucleotide sequence that will result in a different amino acid) and are complementary to the template DNA on opposite strands.[7]

- **Mutant Strand Synthesis:** A high-fidelity DNA polymerase is used to amplify the entire plasmid containing the gene for the receptor subunit, using the mutagenic primers. This results in the synthesis of new plasmids containing the desired mutation.
- **Digestion of Parental DNA:** The parental (non-mutated) DNA, which is methylated, is digested using the DpnI restriction enzyme. The newly synthesized mutant DNA is unmethylated and therefore remains intact.[8]
- **Transformation:** The mutated plasmids are transformed into competent E. coli cells for amplification.
- **Verification:** The plasmids are isolated from the bacteria, and the DNA is sequenced to confirm the presence of the desired mutation.
- **Functional Assay:** The mutated receptor is then expressed in a suitable system (e.g., Xenopus oocytes or HEK293 cells), and its response to **(+)-Desflurane** is assessed using whole-cell patch-clamp electrophysiology to determine if the mutation altered the anesthetic's effect.[1]

Photoaffinity Labeling

This technique is used to identify the binding sites of anesthetics on their target proteins.

Protocol Outline:

- **Synthesis of a Photoreactive Analog:** A photoreactive analog of **(+)-Desflurane** is synthesized. This analog is structurally similar to the parent molecule but contains a photolabile group (e.g., a diazirine) that becomes highly reactive upon exposure to UV light.
- **Incubation:** The photoreactive analog is incubated with the target protein or a cell preparation expressing the target receptor.
- **Photolysis:** The mixture is irradiated with UV light of a specific wavelength. This activates the photolabile group, causing it to form a covalent bond with nearby amino acid residues in the binding pocket.

- Protein Digestion: The covalently labeled protein is isolated and digested into smaller peptide fragments using proteolytic enzymes (e.g., trypsin).
- Mass Spectrometry: The peptide fragments are analyzed by mass spectrometry to identify the specific amino acid residues that have been covalently modified by the photoreactive analog. This reveals the location of the binding site.[9]

Conclusion

The binding profile of **(+)-Desflurane** is characterized by its dual action as a positive allosteric modulator of inhibitory GABA-A receptors and a non-competitive antagonist of excitatory NMDA receptors. While specific quantitative binding data for the (+)-enantiomer is an area requiring further investigation, the methodologies outlined in this guide provide a robust framework for elucidating the precise molecular interactions of this and other anesthetic agents. A comprehensive understanding of the stereospecific binding and functional modulation of neuronal targets by individual anesthetic enantiomers is paramount for the rational design of future anesthetics with improved efficacy and safety profiles.

Need Custom Synthesis?

BenchChem offers custom synthesis for rare earth carbides and specific isotopic labeling.

Email: info@benchchem.com or [Request Quote Online](#).

References

- 1. [benchchem.com](https://www.benchchem.com) [[benchchem.com](https://www.benchchem.com)]
- 2. Modulation of NMDA receptor function by ketamine and magnesium. Part II: interactions with volatile anesthetics - PubMed [pubmed.ncbi.nlm.nih.gov]
- 3. Lack of stereospecific effects of isoflurane and desflurane isomers in isolated guinea pig hearts - PubMed [pubmed.ncbi.nlm.nih.gov]
- 4. Stereospecific effects of inhalational general anesthetic optical isomers on nerve ion channels - PubMed [pubmed.ncbi.nlm.nih.gov]
- 5. Kinetics and potency of desflurane (I-653) in volunteers - PubMed [pubmed.ncbi.nlm.nih.gov]
- 6. [rsds.org](https://www.rsds.org) [[rsds.org](https://www.rsds.org)]

- [7. Site-Directed Mutagenesis \[protocols.io\]](#)
- [8. assaygenie.com \[assaygenie.com\]](#)
- [9. Identification of General Anesthetic Target Protein-Binding Sites by Photoaffinity Labeling and Mass Spectrometry - PubMed \[pubmed.ncbi.nlm.nih.gov\]](#)
- To cite this document: BenchChem. [The Binding Profile of (+)-Desflurane: A Technical Guide]. BenchChem, [2026]. [Online PDF]. Available at: [\[https://www.benchchem.com/product/b1242257/docs#the-binding-profile-of-desflurane-a-technical-guide\]](https://www.benchchem.com/product/b1242257/docs#the-binding-profile-of-desflurane-a-technical-guide)

Disclaimer & Data Validity:

The information provided in this document is for Research Use Only (RUO) and is strictly not intended for diagnostic or therapeutic procedures. While BenchChem strives to provide accurate protocols, we make no warranties, express or implied, regarding the fitness of this product for every specific experimental setup.

Technical Support: The protocols provided are for reference purposes. Unsure if this reagent suits your experiment?

Need Industrial/Bulk Grade? [Request Custom Synthesis Quote](#)

BenchChem

Our mission is to be the trusted global source of essential and advanced chemicals, empowering scientists and researchers to drive progress in science and industry.

Contact

Address: 3281 E Guasti Rd
Ontario, CA 91761, United States
Phone: (601) 213-4426
Email: info@benchchem.com

[Contact our Ph.D. Support Team for a compatibility check](#)

