

Initial Characterization of (+)-Desflurane: A Technical Guide

Author: BenchChem Technical Support Team. **Date:** April 2026

Compound of Interest

Compound Name: (+)-Desflurane

CAS No.: 142916-68-5

Cat. No.: B1242257

[Get Quote](#)

For Researchers, Scientists, and Drug Development Professionals

Abstract

Desflurane, a widely used volatile anesthetic, is administered as a racemic mixture of its two enantiomers: **(+)-Desflurane** and **(-)-Desflurane**. Emerging research into the stereospecific actions of anesthetic agents suggests that individual enantiomers may possess distinct pharmacological profiles, potentially offering improved therapeutic windows and reduced side effects. This technical guide provides a comprehensive overview of the foundational steps required for the initial characterization of the **(+)-Desflurane** enantiomer. While specific quantitative data for the individual enantiomers of Desflurane are not extensively available in publicly accessible literature, this document outlines the critical experimental protocols and data presentation frameworks necessary for such a characterization. It serves as a roadmap for researchers embarking on the investigation of enantiopure volatile anesthetics, drawing parallels from the established stereoselective effects of related compounds like isoflurane.

Introduction

Volatile anesthetics are mainstays in modern surgical practice, enabling a state of reversible unconsciousness, amnesia, and immobility. Desflurane (1,2,2,2-tetrafluoroethyl difluoromethyl ether) is notable for its rapid onset and offset, a characteristic attributed to its low solubility in blood and tissues.[1] Like many of its predecessors, including isoflurane and enflurane, Desflurane is a chiral molecule and is clinically administered as a 1:1 racemic mixture of its (R) and (S) enantiomers.[1] It has been determined that **(+)-Desflurane** corresponds to the (S)-configuration.[2]

The principle of stereopharmacology dictates that enantiomers of a chiral drug can exhibit different interactions with chiral biological targets such as receptors and ion channels.[3] This can lead to variations in potency, efficacy, and toxicity. Studies on other volatile anesthetics, such as isoflurane, have demonstrated clear stereoselective effects on neuronal ion channels, with one enantiomer being more potent than the other at specific targets.[4] Such findings strongly suggest that the individual enantiomers of Desflurane may also possess unique pharmacological properties. A thorough characterization of the **(+)-Desflurane** enantiomer is therefore a critical step toward understanding its potential as a refined anesthetic agent.

This guide outlines the essential components of an initial characterization study for **(+)-Desflurane**, focusing on its physicochemical properties, receptor and ion channel interactions, and key physiological effects.

Physicochemical and Pharmacokinetic Properties

A foundational aspect of characterizing any new chemical entity is the determination of its fundamental physicochemical and pharmacokinetic parameters. While many of these properties are expected to be identical for both enantiomers, subtle differences in their interaction with chiral environments during absorption, distribution, metabolism, and excretion (ADME) are possible.

Table 1: Physicochemical and Pharmacokinetic Data

Parameter	Racemic Desflurane	(+)-Desflurane	(-)-Desflurane
IUPAC Name	(RS)-2-(difluoromethoxy)-1,1,1,2-tetrafluoroethane	(S)-2-(difluoromethoxy)-1,1,1,2-tetrafluoroethane	(R)-2-(difluoromethoxy)-1,1,1,2-tetrafluoroethane
Molecular Formula	C3H2F6O	C3H2F6O	C3H2F6O
Molar Mass (g/mol)	168.04	168.04	168.04
Boiling Point (°C)	22.8	Data not available	Data not available
Vapor Pressure (mmHg at 20°C)	681	Data not available	Data not available
Blood:Gas Partition Coefficient	0.42	Data not available	Data not available
Oil:Gas Partition Coefficient	18.7	Data not available	Data not available
Metabolism (%)	< 0.02	Data not available	Data not available

Note: Specific data for the individual enantiomers are not currently available in the reviewed literature. The table is structured to highlight the necessary data points for a complete characterization.

Receptor and Ion Channel Interactions

The anesthetic effects of Desflurane are mediated through its interaction with various ligand-gated and voltage-gated ion channels in the central nervous system.[5] The primary targets include GABA-A receptors, glycine receptors, and NMDA receptors.[5] Stereoselective interactions with these targets are anticipated and would form the core of the initial pharmacological characterization.

Table 2: Receptor and Ion Channel Modulation

Target	Parameter	Racemic Desflurane	(+)-Desflurane	(-)-Desflurane
GABA-A Receptor	Potentialiation of GABA-induced Cl ⁻ current (EC ₅₀)	Data not available	Data not available	Data not available
Direct Activation (EC ₅₀)	Data not available	Data not available	Data not available	
Glycine Receptor	Potentialiation of Glycine-induced Cl ⁻ current (EC ₅₀)	Data not available	Data not available	Data not available
NMDA Receptor	Inhibition of NMDA-induced current (IC ₅₀)	Data not available	Data not available	Data not available
Two-Pore Domain K ⁺ Channels (e.g., TREK-1)	Activation (% of control)	Data not available	Data not available	Data not available
Voltage-gated Na ⁺ Channels	Inhibition of peak current (IC ₅₀)	Data not available	Data not available	Data not available

Note: Quantitative data for the individual enantiomers of Desflurane are not available in the reviewed literature. This table outlines the key parameters to be determined.

Physiological Effects

The clinical effects of an anesthetic are the ultimate measure of its utility. A comparative analysis of the in vivo effects of the **(+)-Desflurane** enantiomer against the racemic mixture and the (-)-enantiomer is crucial.

Table 3: In Vivo Physiological Effects

Parameter	Racemic Desflurane	(+)-Desflurane	(-)-Desflurane
Anesthetic Potency (MAC in rats/mice)	~7.3% (in rats)	Data not available	Data not available
Cardiovascular Effects			
Mean Arterial Pressure (at 1 MAC)	Dose-dependent decrease	Data not available	Data not available
Heart Rate (at 1 MAC)	Increase	Data not available	Data not available
Systemic Vascular Resistance (at 1 MAC)	Dose-dependent decrease	Data not available	Data not available
Respiratory Effects			
Respiratory Rate (at 1 MAC)	Increase	Data not available	Data not available
Tidal Volume (at 1 MAC)	Decrease	Data not available	Data not available
Neuromuscular Effects			
Potentialiation of NMBAs (e.g., rocuronium)	Yes	Data not available	Data not available

Note: This table presents known effects of racemic Desflurane and highlights the data required for a comparative characterization of the enantiomers. MAC values can vary with age and species.[\[6\]](#)[\[7\]](#)

Experimental Protocols

Detailed and robust experimental protocols are essential for generating reliable and reproducible data. The following sections outline the key methodologies for the initial characterization of **(+)-Desflurane**.

Enantiomeric Separation of Desflurane

Objective: To obtain highly pure **(+)-Desflurane** and **(-)-Desflurane** from the racemic mixture for subsequent *in vitro* and *in vivo* testing.

Methodology: Preparative Gas Chromatography[8][9]

- **Stationary Phase:** A chiral stationary phase is essential for the separation of enantiomers. A commonly used phase for volatile anesthetics is a derivatized γ -cyclodextrin, such as octakis(3-O-butanoyl-2,6-di-O-n-pentyl)- γ -cyclodextrin, dissolved in a polysiloxane.[8]
- **Instrumentation:** A preparative gas chromatograph equipped with a packed column containing the chiral stationary phase and a flame ionization detector (FID) is used.
- **Operating Conditions:**
 - **Carrier Gas:** Helium or Nitrogen at an optimized flow rate.
 - **Injector Temperature:** Set to ensure rapid volatilization of the sample without degradation.
 - **Oven Temperature Program:** An isothermal or temperature-programmed method is developed to achieve baseline separation of the two enantiomers.
 - **Detector Temperature:** Maintained at a higher temperature than the column to prevent condensation.
- **Sample Injection:** The racemic Desflurane is injected in discrete volumes.
- **Fraction Collection:** The eluting peaks corresponding to the individual enantiomers are collected separately using a trapping system, often cooled with liquid nitrogen.
- **Purity Analysis:** The enantiomeric excess (e.e.) of the collected fractions is determined using an analytical gas chromatograph with a chiral column.

In Vitro Characterization: Two-Electrode Voltage Clamp (TEVC) Assay

Objective: To quantify the modulatory effects of **(+)-Desflurane** on ligand-gated ion channels (e.g., GABA-A, Glycine, NMDA receptors) expressed in *Xenopus laevis* oocytes.

Methodology:[\[10\]](#)

- Oocyte Preparation: *Xenopus laevis* oocytes are harvested and defolliculated.
- cRNA Injection: Oocytes are injected with cRNAs encoding the subunits of the target receptor (e.g., $\alpha 1$, $\beta 2$, $\gamma 2s$ for GABA-A receptors).
- Incubation: Injected oocytes are incubated for 2-5 days to allow for receptor expression.
- Electrophysiological Recording:
 - An oocyte is placed in a recording chamber and perfused with a standard bathing solution.
 - Two microelectrodes, one for voltage sensing and one for current injection, are inserted into the oocyte.
 - The membrane potential is clamped at a holding potential (e.g., -70 mV).
- Drug Application:
 - The agonist for the target receptor (e.g., GABA) is applied at a concentration that elicits a submaximal current (e.g., EC_{10}).
 - Once a stable baseline response is established, the agonist is co-applied with varying concentrations of **(+)-Desflurane**.
 - The potentiation or inhibition of the agonist-induced current is measured.
- Data Analysis: Concentration-response curves are generated, and parameters such as EC_{50} (for potentiation) or IC_{50} (for inhibition) are calculated.

In Vivo Characterization: Determination of Minimum Alveolar Concentration (MAC)

Objective: To determine the anesthetic potency of **(+)-Desflurane** in an animal model (e.g., rats or mice).

Methodology:[6]

- **Animal Preparation:** Adult rats are anesthetized with **(+)-Desflurane** via a calibrated vaporizer. The animals are intubated and mechanically ventilated. Core body temperature is maintained at 37°C.
- **Anesthetic Administration:** The end-tidal concentration of **(+)-Desflurane** is monitored continuously.
- **Equilibration:** The animal is allowed to equilibrate at a specific end-tidal concentration for at least 15 minutes.
- **Noxious Stimulus:** A standardized noxious stimulus (e.g., tail clamp) is applied for a defined period (e.g., 60 seconds).
- **Response Assessment:** The presence or absence of a purposeful motor response is recorded.
- **Bracketing Method:** The end-tidal concentration is adjusted for the next animal based on the response of the previous one (e.g., if the animal moves, the concentration is increased for the next animal). This "up-and-down" method is continued until a sufficient number of crossover events (a move followed by a no-move, or vice versa) are observed.
- **MAC Calculation:** The MAC is calculated as the mean of the end-tidal concentrations at the crossover points.

Visualizations

Signaling Pathways

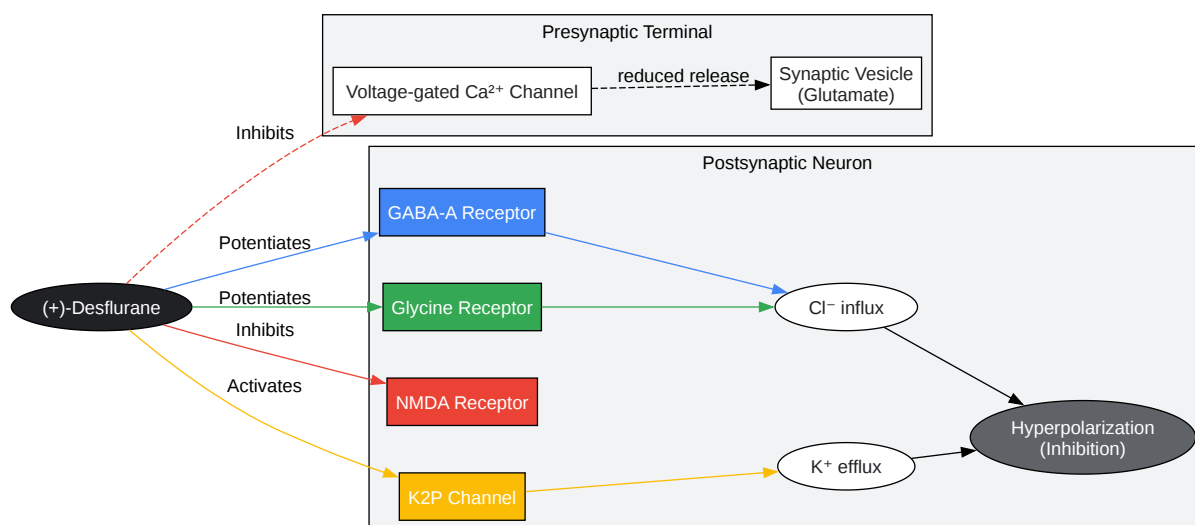

[Click to download full resolution via product page](#)

Caption: Putative signaling pathways for **(+)-Desflurane** at the synapse.

Experimental Workflow

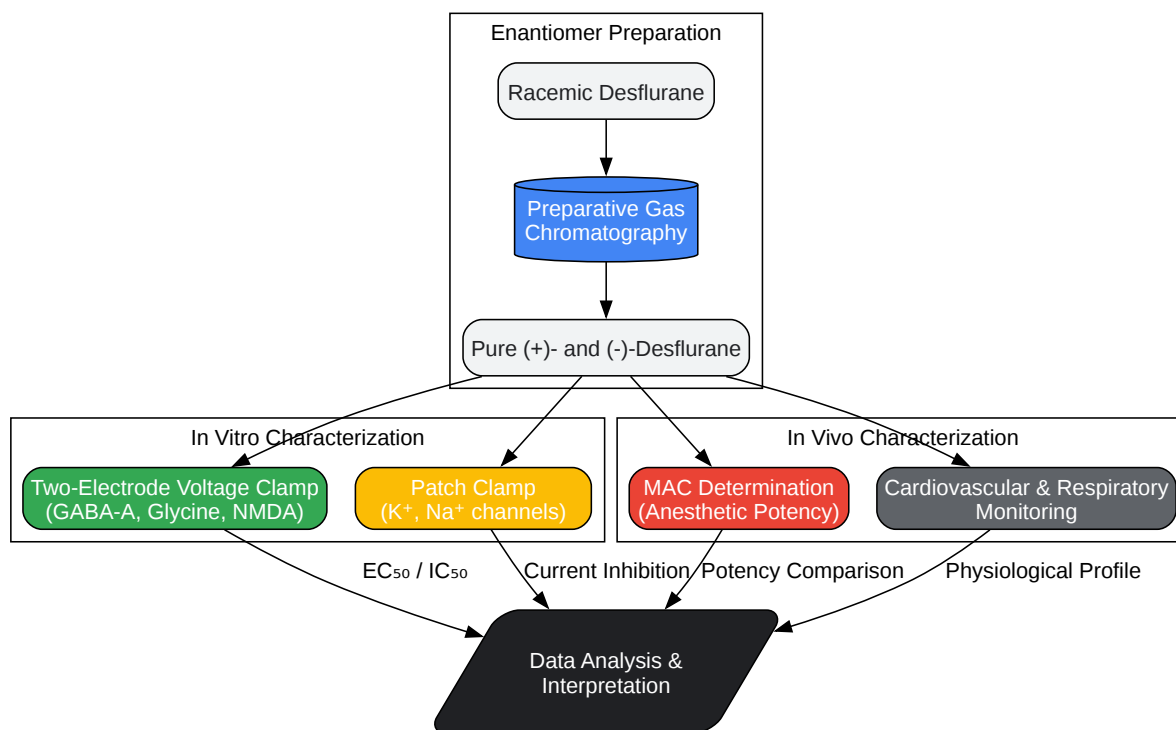

[Click to download full resolution via product page](#)

Caption: Workflow for the initial characterization of **(+)-Desflurane**.

Conclusion

The initial characterization of the **(+)-Desflurane** enantiomer represents a significant step towards a more nuanced understanding of volatile anesthesia. While this guide provides a framework for such an investigation, it also highlights the current gap in publicly available, enantiomer-specific data for Desflurane. By following the outlined experimental protocols,

researchers can systematically elucidate the pharmacological and physiological profile of (+)-**Desflurane**. This knowledge is not only of academic interest but also holds the potential for the development of a new generation of anesthetic agents with improved safety and efficacy profiles, ultimately benefiting patient care. The stereospecific investigation of existing racemic drugs remains a fertile ground for therapeutic innovation.

Need Custom Synthesis?

BenchChem offers custom synthesis for rare earth carbides and specific isotopic labeling.

Email: info@benchchem.com or [Request Quote Online](#).

References

- [1. benchchem.com \[benchchem.com\]](#)
- [2. benchchem.com \[benchchem.com\]](#)
- [3. Cardiovascular and respiratory actions of desflurane: is desflurane different from isoflurane? - PubMed \[pubmed.ncbi.nlm.nih.gov\]](#)
- [4. Desflurane - StatPearls - NCBI Bookshelf \[ncbi.nlm.nih.gov\]](#)
- [5. Cardiovascular effects of desflurane in experimental animals and volunteers - PubMed \[pubmed.ncbi.nlm.nih.gov\]](#)
- [6. Determination of Minimum Alveolar Concentration for Isoflurane and Sevoflurane in a Rodent Model of Human Metabolic Syndrome - PMC \[pmc.ncbi.nlm.nih.gov\]](#)
- [7. Minimum alveolar concentration of desflurane in patients older than 65 yr - PubMed \[pubmed.ncbi.nlm.nih.gov\]](#)
- [8. The stereospecific effects of isoflurane isomers in vivo - PubMed \[pubmed.ncbi.nlm.nih.gov\]](#)
- [9. Respiratory effects of desflurane anesthesia on spontaneous ventilation in infants and children - PubMed \[pubmed.ncbi.nlm.nih.gov\]](#)
- [10. Ionic Mechanisms of Desflurane on Prolongation of Action Potential Duration in Rat Ventricular Myocytes - PMC \[pmc.ncbi.nlm.nih.gov\]](#)
- To cite this document: BenchChem. [Initial Characterization of (+)-Desflurane: A Technical Guide]. BenchChem, [2026]. [Online PDF]. Available at: [\[https://www.benchchem.com/product/b1242257/docs#initial-characterization-of-desflurane-a-technical-guide\]](https://www.benchchem.com/product/b1242257/docs#initial-characterization-of-desflurane-a-technical-guide)

Disclaimer & Data Validity:

The information provided in this document is for Research Use Only (RUO) and is strictly not intended for diagnostic or therapeutic procedures. While BenchChem strives to provide accurate protocols, we make no warranties, express or implied, regarding the fitness of this product for every specific experimental setup.

Technical Support: The protocols provided are for reference purposes. Unsure if this reagent suits your experiment?

Need Industrial/Bulk Grade? [Request Custom Synthesis Quote](#)

BenchChem

Our mission is to be the trusted global source of essential and advanced chemicals, empowering scientists and researchers to drive progress in science and industry.

Contact

Address: 3281 E Guasti Rd
Ontario, CA 91761, United States
Phone: (601) 213-4426
Email: info@benchchem.com

[Contact our Ph.D. Support Team for a compatibility check](#)