

Application Notes and Protocols for Selective Hydrogen Evolution Using Manganese Compounds

Author: BenchChem Technical Support Team. **Date:** April 2026

Compound of Interest

Compound Name: *Hydrogen manganate*

Cat. No.: *B1242573*

[Get Quote](#)

For Researchers, Scientists, and Drug Development Professionals

This document provides detailed application notes and protocols for the utilization of manganese-based compounds as catalysts for the selective hydrogen evolution reaction (HER). Manganese, being an earth-abundant and cost-effective metal, presents a promising alternative to precious metal catalysts like platinum.[1] This guide covers the synthesis of various classes of manganese catalysts, experimental procedures for evaluating their electrocatalytic performance, and methods for characterizing their structural and electrochemical properties.

Overview of Manganese-Based HER Catalysts

Manganese compounds have emerged as a versatile class of catalysts for the electrochemical production of hydrogen gas. Their catalytic activity stems from manganese's multiple oxidation states and its ability to form diverse coordination complexes and solid-state materials. The primary categories of manganese-based HER catalysts include:

- **Manganese Oxides/Sulfides/Phosphides:** These inorganic materials, often in nanostructured forms, serve as heterogeneous catalysts. Their activity is influenced by their crystal structure, morphology, and the presence of defects.^{[1][2]}
- **Single-Atom Mn-N-C Catalysts:** In these materials, individual manganese atoms are dispersed and coordinated within a nitrogen-doped carbon matrix. This atomic dispersion maximizes the utilization of the metal centers and can lead to exceptional catalytic activity.
- **Molecular Manganese Complexes:** These are discrete, well-defined coordination compounds that act as homogeneous or immobilized molecular catalysts. Their catalytic properties can be systematically tuned by modifying the ligand environment around the manganese center.

Experimental Protocols

This section details the synthesis and characterization protocols for representative manganese-based HER catalysts, as well as the procedures for electrochemical performance evaluation.

Catalyst Synthesis

This protocol describes the synthesis of α -MnO₂ nanowires, which are effective HER catalysts.^[3]

Materials:

- Manganese sulfate monohydrate (MnSO₄·H₂O)
- Potassium permanganate (KMnO₄)
- Deionized (DI) water
- Teflon-lined stainless steel autoclave

Procedure:

- Prepare a 0.05 M aqueous solution of MnSO₄·H₂O.
- Prepare a 0.05 M aqueous solution of KMnO₄.

- In a typical synthesis, mix 40 mL of the MnSO_4 solution and 40 mL of the KMnO_4 solution in a beaker under vigorous stirring.
- Transfer the resulting mixture into a 100 mL Teflon-lined stainless steel autoclave.
- Seal the autoclave and heat it in an oven at 140°C for 12 hours.
- After the reaction, allow the autoclave to cool down to room temperature naturally.
- Collect the black precipitate by centrifugation or filtration.
- Wash the product repeatedly with DI water and ethanol to remove any unreacted precursors and byproducts.
- Dry the final product in a vacuum oven at 60°C for 12 hours.

This protocol outlines a solid-state reaction method to synthesize MnP nanoparticles.[\[4\]](#)

Materials:

- Manganese(II) chloride (MnCl_2)
- Sodium hypophosphite (NaH_2PO_2)
- Argon gas

Procedure:

- Thoroughly grind a 1:1 molar ratio of MnCl_2 and NaH_2PO_2 in an agate mortar.
- Place the ground powder in a quartz tube furnace.
- Heat the furnace to 300°C under a constant flow of argon gas and hold for 2 hours.
- Increase the temperature to 600°C and hold for another 3 hours to ensure complete phosphidation.
- After cooling to room temperature under argon, the resulting black powder is the MnP catalyst.

- Wash the product with dilute acid to remove any unreacted precursors, followed by DI water and ethanol.
- Dry the final product in a vacuum oven.

This protocol describes a pyrolysis method to synthesize a single-atom Mn-N-C catalyst using a metal-organic framework (MOF) as a precursor.

Materials:

- Zinc nitrate hexahydrate ($\text{Zn}(\text{NO}_3)_2 \cdot 6\text{H}_2\text{O}$)
- 2-methylimidazole
- Manganese(II) acetate tetrahydrate ($\text{Mn}(\text{CH}_3\text{COO})_2 \cdot 4\text{H}_2\text{O}$)
- Methanol
- Argon gas

Procedure:

- Dissolve $\text{Zn}(\text{NO}_3)_2 \cdot 6\text{H}_2\text{O}$ and a small amount of $\text{Mn}(\text{CH}_3\text{COO})_2 \cdot 4\text{H}_2\text{O}$ in methanol.
- Separately, dissolve 2-methylimidazole in methanol.
- Slowly add the 2-methylimidazole solution to the metal salt solution under stirring to form a Mn-doped ZIF-8 precursor.
- Stir the mixture for 24 hours at room temperature.
- Collect the precipitate by centrifugation, wash with methanol, and dry.
- Pyrolyze the Mn-doped ZIF-8 precursor in a tube furnace under an argon atmosphere at 900°C for 2 hours.
- After cooling, the resulting black powder is the Mn-N-C single-atom catalyst.

This protocol details the synthesis of a representative molecular HER catalyst, $[\text{Mn}(\text{bpy})(\text{CO})_3\text{Br}]$.

Materials:

- Dimanganese decacarbonyl ($\text{Mn}_2(\text{CO})_{10}$)
- 2,2'-bipyridine (bpy)
- Bromine (Br_2)
- Hexane
- Dichloromethane (CH_2Cl_2)

Procedure:

- Reflux a solution of $\text{Mn}_2(\text{CO})_{10}$ in hexane to form $\text{Mn}(\text{CO})_5\text{Br}$.
- React the $\text{Mn}(\text{CO})_5\text{Br}$ with an equimolar amount of 2,2'-bipyridine in a suitable solvent like dichloromethane at room temperature.
- The product, $[\text{Mn}(\text{bpy})(\text{CO})_3\text{Br}]$, will precipitate out of the solution.
- Collect the solid product by filtration, wash with a small amount of cold solvent, and dry under vacuum.

Catalyst Characterization

To understand the physical and chemical properties of the synthesized manganese catalysts, a suite of characterization techniques should be employed.

Table 1: Key Characterization Techniques for Manganese-Based HER Catalysts

Technique	Information Obtained
X-ray Diffraction (XRD)	Crystal structure, phase purity, and crystallite size.[5]
Scanning Electron Microscopy (SEM)	Morphology, particle size, and surface topography.[2]
Transmission Electron Microscopy (TEM)	High-resolution imaging of morphology, lattice fringes, and elemental mapping (with EDX).[2]
X-ray Photoelectron Spectroscopy (XPS)	Elemental composition, oxidation states of manganese, and surface chemistry.[2][6]
X-ray Absorption Spectroscopy (XAS)	Local coordination environment and oxidation state of manganese atoms.
Brunauer-Emmett-Teller (BET) Analysis	Specific surface area and pore size distribution.
Raman Spectroscopy	Vibrational modes, providing information on crystal structure and defects.

Electrochemical Hydrogen Evolution (HER) Testing

The following protocol outlines the standard procedure for evaluating the HER performance of the synthesized catalysts using a three-electrode setup and a rotating disk electrode (RDE).[7]

Materials and Equipment:

- Potentiostat/Galvanostat
- Three-electrode electrochemical cell
- Working electrode (e.g., glassy carbon RDE)
- Counter electrode (e.g., platinum wire or graphite rod)
- Reference electrode (e.g., Ag/AgCl or Calomel)
- Electrolyte (e.g., 0.5 M H₂SO₄ for acidic conditions or 1.0 M KOH for alkaline conditions)

- Catalyst ink (prepared by dispersing the catalyst powder in a solvent with a binder like Nafion)
- High-purity hydrogen and nitrogen or argon gas

Procedure:

- Working Electrode Preparation:
 - Polish the glassy carbon RDE to a mirror finish using alumina slurries of decreasing particle size.
 - Sonochemically clean the electrode in DI water and ethanol.
 - Drop-cast a specific volume of the catalyst ink onto the RDE surface and let it dry to form a uniform thin film.
- Electrochemical Measurements:
 - Assemble the three-electrode cell with the prepared working electrode, counter electrode, and reference electrode in the electrolyte.
 - Purge the electrolyte with high-purity N₂ or Ar for at least 30 minutes to remove dissolved oxygen.
 - Perform cyclic voltammetry (CV) to activate the catalyst and clean the electrode surface.
 - Record linear sweep voltammetry (LSV) at a slow scan rate (e.g., 5 mV/s) to obtain the polarization curve for HER. The potential should be swept from the open-circuit potential towards more negative potentials.
 - All measured potentials should be converted to the Reversible Hydrogen Electrode (RHE) scale.
 - Perform chronoamperometry or chronopotentiometry to assess the long-term stability of the catalyst.
- Data Analysis:

- Overpotential (η): Determine the overpotential required to achieve a specific current density (e.g., 10 mA/cm²), which is a key metric for catalyst activity.
- Tafel Plot: Plot the overpotential (η) versus the logarithm of the current density ($\log |j|$). The linear portion of this plot can be fitted to the Tafel equation ($\eta = b \log |j| + a$) to determine the Tafel slope (b), which provides insight into the HER mechanism.[8]
- Turnover Frequency (TOF): Calculate the TOF to assess the intrinsic activity of the catalyst, representing the number of hydrogen molecules produced per active site per unit time. This requires an estimation of the number of active sites.

This protocol describes how to determine the Faradaic efficiency of the HER process, which is the ratio of the experimentally measured amount of hydrogen produced to the theoretical amount calculated from the total charge passed.[9]

Method: Gas Chromatography

- Conduct bulk electrolysis at a constant potential in a sealed, gas-tight electrochemical cell.
- Periodically, or at the end of the experiment, collect a known volume of the headspace gas using a gas-tight syringe.
- Inject the gas sample into a gas chromatograph (GC) equipped with a thermal conductivity detector (TCD) and a suitable column (e.g., a molecular sieve column).
- Quantify the amount of H₂ produced by comparing the peak area to a calibration curve generated using known concentrations of H₂.
- Calculate the theoretical amount of H₂ that should have been produced based on the total charge passed during the electrolysis (Faraday's law).
- The Faradaic efficiency is then calculated as: (moles of H₂ measured / moles of H₂ theoretical) x 100%.

Data Presentation

The performance of different manganese-based HER catalysts can be compared using the following key metrics.

Table 2: Performance Comparison of Representative Manganese-Based HER Catalysts

Catalyst	Electrolyte	Overpotential @ 10 mA/cm ² (mV vs. RHE)	Tafel Slope (mV/dec)	Stability	Reference
α -MnO ₂ Nanowires	1.0 M KOH	~350	~120	Moderate	[1]
MnP/Graphene	1.0 M KOH	~150	~75	Good	[4]
Co ₃ S ₄ /MnS ₂	1.0 M KOH	197 (at 20 mA/cm ²)	Not reported	Good	[1]
Mn-N-C	0.5 M H ₂ SO ₄	~250	~90	Good	[10]
[Mn(bpy)(CO) ₃ Br]	Acetonitrile/TFAC	Varies with acid conc.	Not directly comparable	Varies	

Note: The performance of molecular catalysts is often reported in terms of turnover frequency (TOF) and is highly dependent on the experimental conditions, particularly the concentration of the proton source.

Visualizations

Experimental Workflow

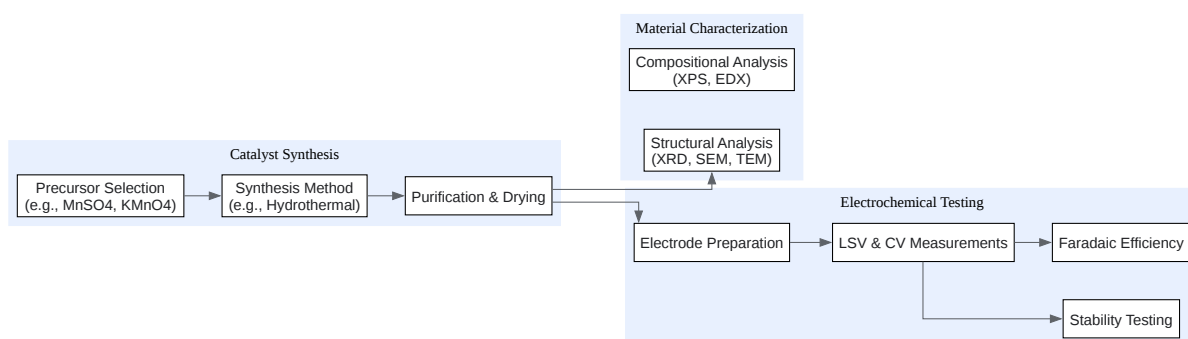

[Click to download full resolution via product page](#)

Caption: General experimental workflow for the synthesis, characterization, and electrochemical evaluation of manganese-based HER catalysts.

Proposed HER Mechanism on a Heterogeneous Manganese Catalyst Surface

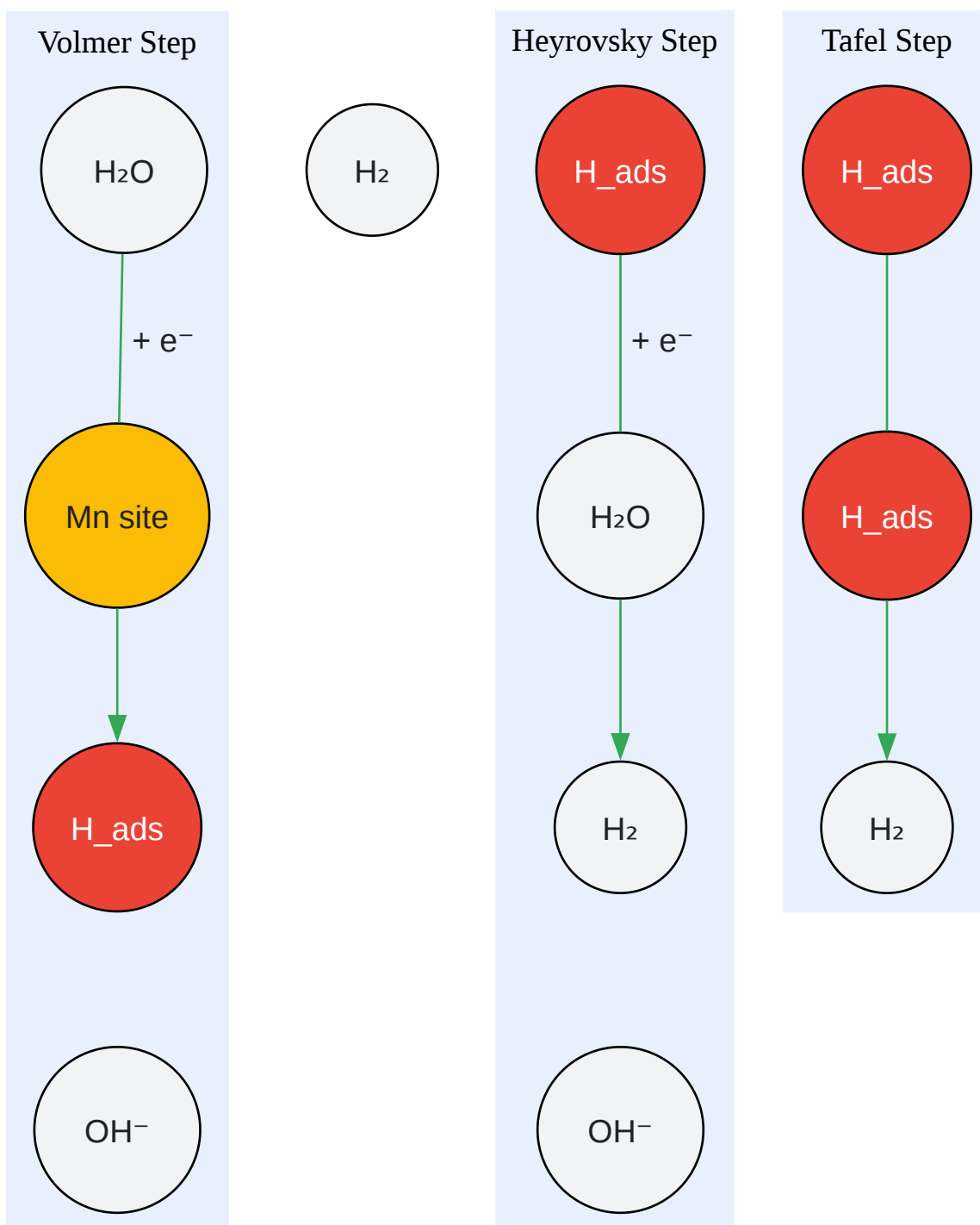

[Click to download full resolution via product page](#)

Caption: Possible reaction pathways for the hydrogen evolution reaction (HER) on a heterogeneous manganese catalyst surface in alkaline media.

Catalytic Cycle of a Molecular Manganese Complex for HER

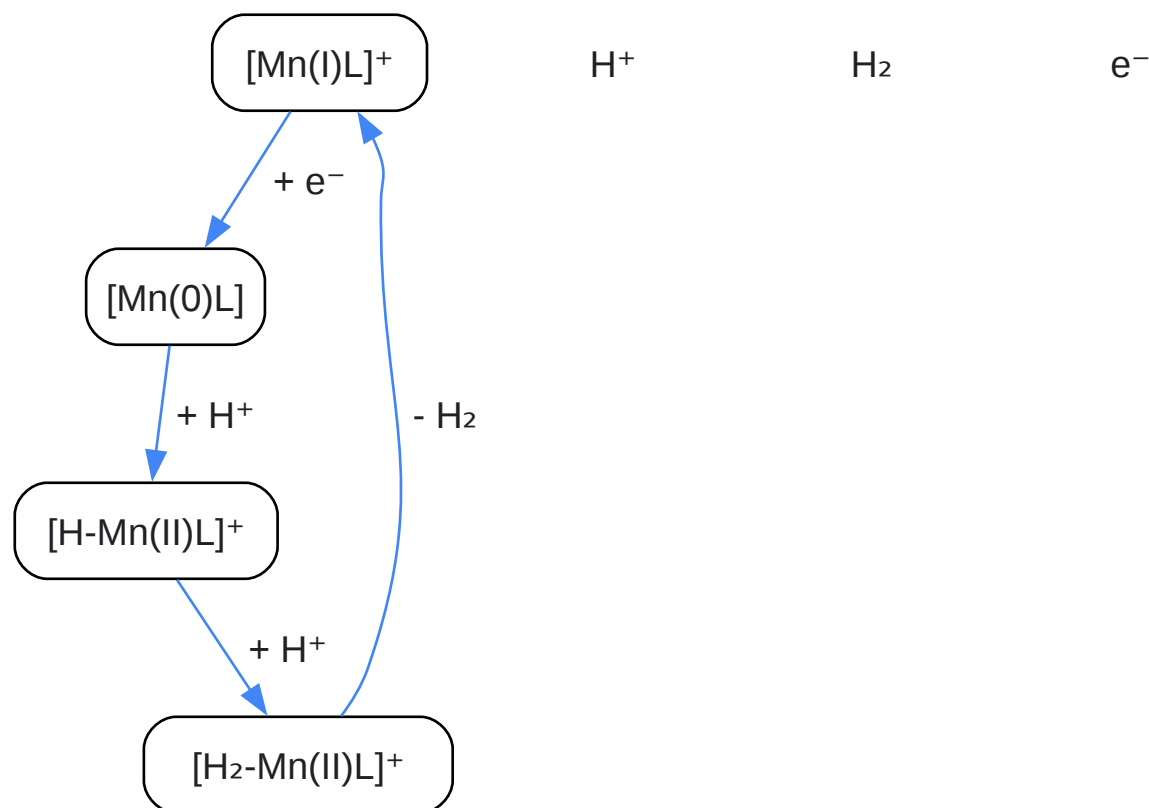

[Click to download full resolution via product page](#)

Need Custom Synthesis?

BenchChem offers custom synthesis for rare earth carbides and specific isotopic labeling.

Email: info@benchchem.com or [Request Quote Online](#).

References

- 1. [mdpi.com \[mdpi.com\]](https://doi.org/10.3390/11010011)
- 2. [mdpi.com \[mdpi.com\]](https://doi.org/10.3390/11010011)
- 3. Mild hydrothermal synthesis of γ - MnO_2 nanostructures and their phase transformation to α - MnO_2 nanowires | [Journal of Materials Research | Cambridge Core \[cambridge.org\]](https://doi.org/10.1002/jmr.201700011)

- [4. Evaluating the phase-dependent electrocatalytic activity of manganese phosphides for the hydrogen evolution reaction - Journal of Materials Chemistry A \(RSC Publishing\) \[pubs.rsc.org\]](#)
- [5. researchgate.net \[researchgate.net\]](#)
- [6. researchgate.net \[researchgate.net\]](#)
- [7. osti.gov \[osti.gov\]](#)
- [8. One-pot synthesis of manganese oxides and cobalt phosphides nanohybrids with abundant heterointerfaces in an amorphous matrix for efficient hydrogen evolution in alkaline solution - Journal of Materials Chemistry A \(RSC Publishing\) \[pubs.rsc.org\]](#)
- [9. researchgate.net \[researchgate.net\]](#)
- [10. researchgate.net \[researchgate.net\]](#)
- [To cite this document: BenchChem. \[Application Notes and Protocols for Selective Hydrogen Evolution Using Manganese Compounds\]. BenchChem, \[2026\]. \[Online PDF\]. Available at: \[https://www.benchchem.com/product/b1242573/docs#application-notes-and-protocols-for-selective-hydrogen-evolution-using-manganese-compounds\]](#)

Disclaimer & Data Validity:

The information provided in this document is for Research Use Only (RUO) and is strictly not intended for diagnostic or therapeutic procedures. While BenchChem strives to provide accurate protocols, we make no warranties, express or implied, regarding the fitness of this product for every specific experimental setup.

Technical Support: The protocols provided are for reference purposes. Unsure if this reagent suits your experiment?

Need Industrial/Bulk Grade? [Request Custom Synthesis Quote](#)

BenchChem

Our mission is to be the trusted global source of essential and advanced chemicals, empowering scientists and researchers to drive progress in science and industry.

Contact

Address: 3281 E Guasti Rd

Ontario, CA 91761, United States

Phone: (601) 213-4426

Email: info@benchchem.com

[Contact our Ph.D. Support Team for a compatibility check](#)