

# Trk-IN-17: A Comparative Analysis of Kinase Selectivity

**Author:** BenchChem Technical Support Team. **Date:** April 2026

## Compound of Interest

Compound Name: *Trk-IN-17*  
Cat. No.: *B12419028*

[Get Quote](#)

For Researchers, Scientists, and Drug Development Professionals

This guide provides a comprehensive comparison of the kinase selectivity profile of **Trk-IN-17** with other prominent Tropomyosin receptor kinase (Trk) inhibitors. The following sections detail the biochemical potency and selectivity of these compounds, the experimental methodologies used for their characterization, and the key signaling pathways involved.

## Introduction to Trk Inhibition

Tropomyosin receptor kinases (Trks) are a family of receptor tyrosine kinases (TrkA, TrkB, and TrkC) that play a crucial role in the development and function of the nervous system. Dysregulation of Trk signaling, often through chromosomal rearrangements leading to gene fusions, is an oncogenic driver in a wide range of adult and pediatric cancers. Small molecule inhibitors targeting the ATP-binding site of Trk kinases have emerged as effective therapeutic agents for these cancers. The selectivity of these inhibitors is a critical factor, as off-target effects on other kinases can lead to undesirable side effects.

## Comparative Selectivity of Trk Inhibitors

The selectivity of a kinase inhibitor is determined by its potency against its intended target compared to its activity against a broad range of other kinases. This is typically quantified by determining the half-maximal inhibitory concentration (IC<sub>50</sub>) or the dissociation constant (K<sub>d</sub>) against a panel of kinases.

While **Trk-IN-17** is a potent Trk inhibitor, specific quantitative data regarding its selectivity against a broad panel of kinases is not publicly available at this time. Information regarding its characterization is primarily found within the patent WO2021148807A1.

In contrast, extensive selectivity data is available for the FDA-approved Trk inhibitors, larotrectinib and entrectinib.

Table 1: Comparison of in vitro Kinase Inhibitory Activity (IC<sub>50</sub> in nM)

Kinase Target	Trk-IN-17	Larotrectinib	Entrectinib
TrkA	Data not publicly available	5-11	1-5
TrkB	Data not publicly available	5-11	1-5
TrkC	Data not publicly available	5-11	1-5
ROS1	Data not publicly available	>1000	1-5
ALK	Data not publicly available	>1000	1-5
TNK2	Data not publicly available	~576	Data not publicly available

#### Key Observations:

- Larotrectinib is a highly selective inhibitor of the Trk family of kinases. When screened against a panel of 226 other kinases, it demonstrated greater than 100-fold selectivity for Trk kinases, with the only significant off-target inhibition observed against TNK2.

- Entrectinib is a multi-kinase inhibitor with potent activity against Trk kinases, as well as ROS1 and ALK. This broader activity profile makes it an effective treatment for cancers driven by fusions involving any of these three kinases.

## Trk Signaling Pathway

The activation of Trk receptors by their neurotrophin ligands initiates a cascade of downstream signaling events that are crucial for cell survival, proliferation, and differentiation. The primary signaling pathways activated by Trks include the RAS/MAPK pathway, the PI3K/Akt pathway, and the PLC $\gamma$  pathway. In cancer, the constitutive activation of these pathways by Trk fusion proteins drives tumor growth and survival.

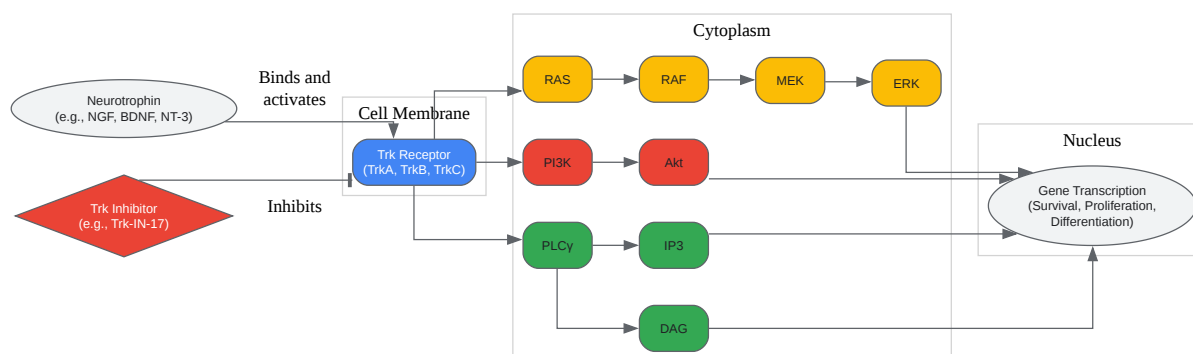

[Click to download full resolution via product page](#)

Caption: The Trk signaling pathway and the point of inhibition by Trk inhibitors.

## Experimental Methodologies for Kinase Selectivity Profiling

The determination of a kinase inhibitor's selectivity profile is a critical step in its preclinical development. Several robust biochemical assays are employed for this purpose.

## LanthaScreen™ Eu Kinase Binding Assay

This assay is a time-resolved fluorescence resonance energy transfer (TR-FRET) based competition binding assay.

Experimental Workflow:

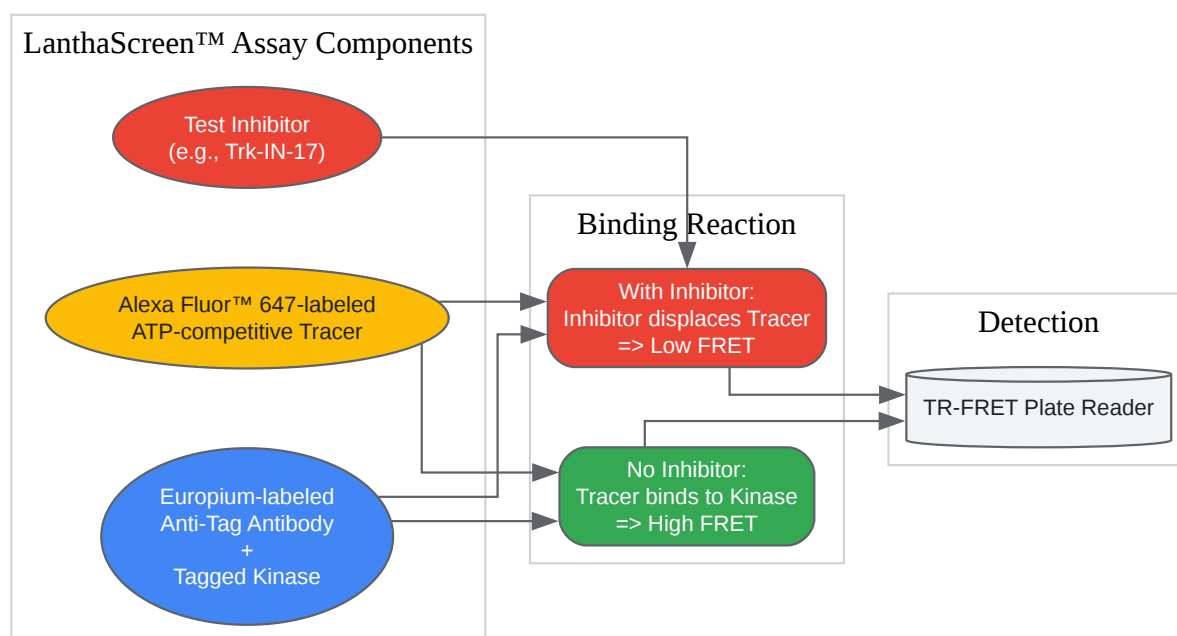

[Click to download full resolution via product page](#)

Caption: Workflow of the LanthaScreen™ Eu Kinase Binding Assay.

Protocol Outline:

- Reagent Preparation:
  - Prepare a serial dilution of the test inhibitor (e.g., **Trk-IN-17**).

- Prepare a solution containing the europium-labeled anti-tag antibody and the tagged kinase of interest.
- Prepare a solution of the Alexa Fluor™ 647-labeled ATP-competitive tracer.
- Assay Assembly:
  - In a microplate, add the serially diluted test inhibitor.
  - Add the kinase/antibody mixture to all wells.
  - Add the tracer solution to all wells to initiate the binding reaction.
- Incubation:
  - Incubate the plate at room temperature for a specified period (e.g., 1 hour) to allow the binding reaction to reach equilibrium.
- Detection:
  - Read the plate on a TR-FRET-compatible plate reader, measuring the emission at two wavelengths (e.g., 665 nm for the acceptor and 615 nm for the donor).
- Data Analysis:
  - Calculate the emission ratio (acceptor/donor).
  - Plot the emission ratio against the inhibitor concentration and fit the data to a dose-response curve to determine the IC50 value.

## KINOMEScan™ Competition Binding Assay

The KINOMEScan™ platform utilizes a competition binding assay to quantify the interaction of a test compound with a large panel of kinases.

Experimental Workflow:

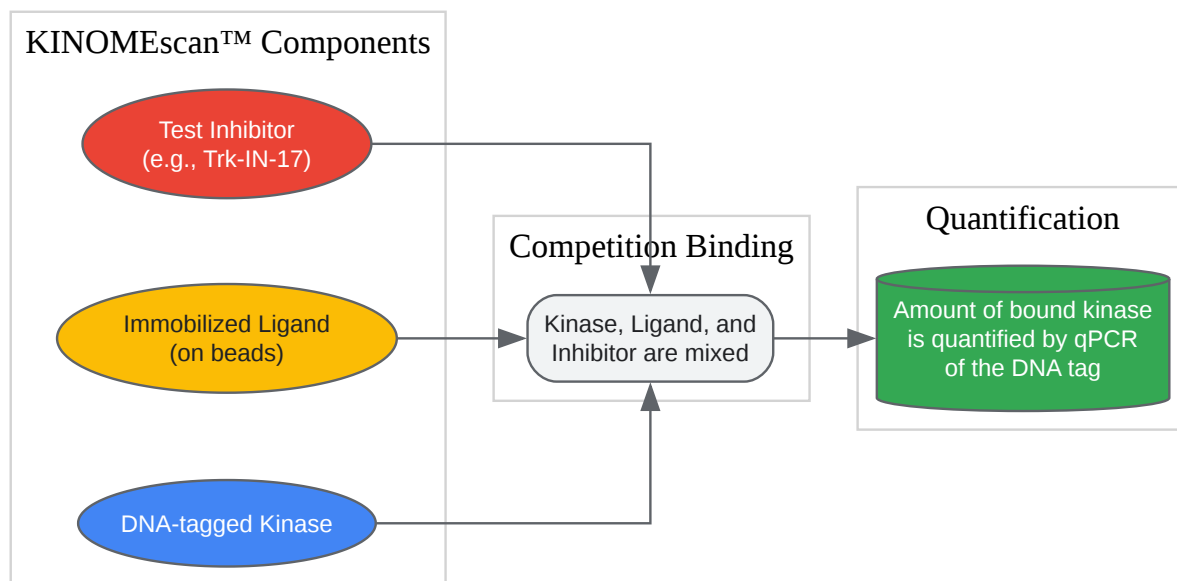

[Click to download full resolution via product page](#)

Caption: Workflow of the KINOMEScan™ Competition Binding Assay.

Protocol Outline:

- Assay Preparation:
  - A large panel of human kinases are individually expressed as fusions with a unique DNA tag.
  - An ATP-site directed ligand is immobilized on a solid support (e.g., beads).
- Competition Binding:
  - The DNA-tagged kinase, the immobilized ligand, and the test inhibitor (at a fixed concentration or in serial dilutions) are combined in a well of a microplate.
  - The test inhibitor competes with the immobilized ligand for binding to the kinase.
- Wash and Elution:

- Unbound components are washed away.
- The bound kinase is eluted from the solid support.
- Quantification:
  - The amount of eluted kinase is quantified by quantitative PCR (qPCR) using the unique DNA tag.
- Data Analysis:
  - The amount of kinase recovered in the presence of the test inhibitor is compared to a control (e.g., DMSO).
  - The results are typically expressed as percent of control, and for dose-response experiments, a  $K_d$  value is determined.

## Conclusion

The selectivity profile of a Trk inhibitor is a critical determinant of its therapeutic window and potential for off-target toxicities. While **Trk-IN-17** is a potent inhibitor of Trk kinases, a detailed public dataset on its broader kinase selectivity is currently unavailable. In contrast, larotrectinib is a highly selective Trk inhibitor, while entrectinib is a potent inhibitor of Trk, ROS1, and ALK. The choice of a specific Trk inhibitor for therapeutic development or as a research tool will depend on the desired selectivity profile and the specific biological question being addressed. The use of standardized and robust biochemical assays, such as LanthaScreen™ and KINOMEscan™, is essential for accurately determining and comparing the selectivity of these important therapeutic agents.

- To cite this document: BenchChem. [Trk-IN-17: A Comparative Analysis of Kinase Selectivity]. BenchChem, [2026]. [Online PDF]. Available at: [\[https://www.benchchem.com/product/b12419028/docs#trk-in-17-a-comparative-analysis-of-kinase-selectivity\]](https://www.benchchem.com/product/b12419028/docs#trk-in-17-a-comparative-analysis-of-kinase-selectivity)

---

### Disclaimer & Data Validity:

The information provided in this document is for Research Use Only (RUO) and is strictly not intended for diagnostic or therapeutic procedures. While BenchChem strives to provide accurate protocols, we make no warranties, express or implied, regarding the fitness of this product for every specific experimental setup.

**Technical Support:** The protocols provided are for reference purposes. Unsure if this reagent suits your experiment?

**Need Industrial/Bulk Grade?** [Request Custom Synthesis Quote](#)

## BenchChem

Our mission is to be the trusted global source of essential and advanced chemicals, empowering scientists and researchers to drive progress in science and industry.

### Contact

Address: 3281 E Guasti Rd  
Ontario, CA 91761, United States  
Phone: (601) 213-4426  
Email: [info@benchchem.com](mailto:info@benchchem.com)

[Contact our Ph.D. Support Team for a compatibility check](#)